

# VC008A / B SERIES FEATURES



## VC008A

筒型多針縫紉機(高貫穿力型)

**Multineedle Cylinder Bed Double Chainstitch Machine (High Penetration Power Type)**



完全自動供油，勾針縱向運動機構，多針雙重鏈式縫

Automatic lubrication system, vertical looper mechanism, multineedle chainstitch mechanism.



採用獨立勾針座，可變化不同的針位元組合，達到一機多用的功能（選配）

Using independent looper holder and can easily change different needle position, Multi-function machine design.(optional)



筒型機身設計，方便環型衣物縫紉

Cylinder machine frame design, easy sewing operation for circular cloth.



按鈕式縫距調整模式，調整簡便快速

Stitch length adjustment by knob, easy and fast.



左側附一輔助設計，拉布穩定，出布更順暢，維護便利

Using one supportive puller on left side which can stabilize the pulling and sewing process.



適用於多種工序的縫紉，適合針織類高級衣物之裝飾車縫

Suitable for multi sewing process, high quality knit material and decorative sewing.



新型軸承式滾輪，縫製時拉布與出布更順暢穩定

New bearing type rear puller handles the material with better stability.

## VC008B

筒型多針縫紉機 (4~6針高速型)

**Multineedle Cylinder Bed Double Chainstitch Machine (4~6 Needles High Speed Type)**

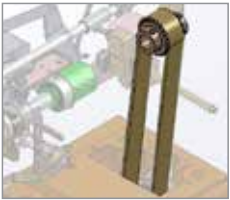

使用皮帶傳動來驅動上下軸，實現高速穩定的縫製

New mechanism uses the belt to drive both upper and lower shaft, provides faster and more stable sewing experience.



平順且低振動，車縫薄料得心應手

High performance with thin material, less vibration and smoother movement.



新型軸承式滾輪，縫製時拉布與出布更順暢穩定

New bearing type rear puller handles the material with better stability.

## V1

Model	Specification				每單位 (Unit)=1.6mm=1/16"																				Remark							
					26	24	22	20	18	16	14	12	10	8	6	4	2	2	4	6	8	10	12	14		16	18	20	22	24	26	
VC008A- VC008B-	04064P	4	8	1/4"(6.4mm)																												
	04085P																															
	04095P																															
	04106P																															
	04127P																															
	04A32-032P					(1/4-1/8-1/8-1/4")*3 (6.4-3.2-3.2-6.4mm)*3																										A
	04A64P					1/4"(6.4mm)																										
12A32-032P	6	12	(1/4-1/8-1/8-1/4")*3 (6.4-3.2-3.2-6.4mm)*3																										B			
12A64P																																
VC008A-	12048P	12	24	3/16"(4.8mm)																												
	12064P																															
	12050P																															
	13032P	13	24*	1/8"(3.2mm)																												
	13064P																													C		
	1332-032P					(1/4-1/8-1/8-1/4")*3 (6.4-3.2-3.2-6.4mm)*3																										
	17032P	17	24*	1/8"(3.2mm)																									D			
	21032P	21	24*	1/8"(3.2mm)																									E			
	23032P	23	24*	1/8"(3.2mm)																									F			

- A: 13 針規格組，配 4 組針 / 勾針
- B: 13 針規格組，配 6 組針 / 勾針
- C: 13 針規格組，配 13 組針 / 勾針
- D: 17 針規格組，配 17 組針 / 勾針
- E: 21 針規格組，配 21 組針 / 勾針
- F: 23 針規格組，配 23 組針 / 勾針

- A: 13-Needle gauge set with 4 sets of needle/ loop.
- B: 13-Needle gauge set with 6 sets of needle/ loop.
- C: 13-Needle gauge set with 13 sets of needle/ loop.
- D: 17-Needle gauge set with 17 sets of needle/ loop.
- E: 21-Needle gauge set with 21 sets of needle/ loop.
- F: 23-Needle gauge set with 23 sets of needle/ loop.

\* 線架組最多可安裝 24 組線

\*The maximum number of threads stand installed is 24 sets.

 mm	1.4-3.6	 mm	12	 Needle No.	UOX113GS #11~#14	 S.P.M. (Max)	4500
---	---------	--	----	--	---------------------	--	------



### 4針機型

### 4-Needle type

VC008A-04XXX  
VC008A-04XXX-XXX

### 12針機型

### 12-Needle type

VC008A-12XXX  
VC008A-12XXX-XXX  
VC008A-13XXX  
VC008A-13XXX-XXX  
VC008A-17XXX  
VC008A-21XXX  
VC008A-23XXX







### 一般平縫

完全自動給油・勾針縱向運動機構・筒型車台・利於圓筒型衣物之縫紉・適用於一般高級衣物之裝飾車縫。

### GENERAL SEAMING

Cylinder bed automatic oiling, back and forth loopers driving mechanism, suitable for decorative sewing on high quality dress or tubular goods.

## V2

Model	Specification			 mm	 mm	2.5-5	 mm	12	 Needle No.	UOX113GS #11~#14	 S.P.M. (Max)	4000	Remark																																																			
														每單位 (Unit)=1.6mm=1/16"																																																		
<table border="1" style="width:100%; text-align:center; border-collapse: collapse;"> <tr> <td>26</td><td>24</td><td>22</td><td>20</td><td>18</td><td>16</td><td>14</td><td>12</td><td>10</td><td>8</td><td>6</td><td>4</td><td>2</td><td>2</td><td>4</td><td>6</td><td>8</td><td>10</td><td>12</td><td>14</td><td>16</td><td>18</td><td>20</td><td>22</td><td>24</td><td>26</td> </tr> <tr> <td colspan="12"></td> <td>2</td><td>4</td><td>6</td><td>8</td><td>10</td><td>12</td><td>14</td><td>16</td><td>18</td><td>20</td><td>22</td><td>24</td><td>26</td> </tr> </table>														26	24	22	20	18	16	14	12	10	8	6	4	2	2	4	6	8	10	12	14	16	18	20	22	24	26													2	4	6	8	10	12	14	16	18	20	22	24	26
26	24	22	20	18	16	14	12	10	8	6	4	2	2	4	6	8	10	12	14	16	18	20	22	24	26																																							
												2	4	6	8	10	12	14	16	18	20	22	24	26																																								
VC008A-	1132-064P	11	22	(1/8-1/4-1/8") (3.2-6.4-3.2mm)																																																												

### [三合一] 褲頭車縫

本機型適用鬆緊帶皺褶型、平坦型、薄牛仔，可以彈性組合出各種常用的4針針位組如1/4-1/4-1/4, 1/4-3/4-1/4...等。

### [3 in 1] WAIST BAND SEWING







This model is applicable to elastic band wrinkled type, flat type, light denim, which offers various 4-needle gauges by one set. E.g.: 1/4-1/4-1/4, 1/4-3/4-1/4...etc.



選購配件	OPTIONAL DEVICE
VCE	

 VCL08S	細齒上拉輪 (鋼質)・薄牛仔 Fine teeth type upper puller (steel).light denim.
 VCL16P VCL28	平輪組 (PU 材質) Flat type puller set (PU)
 P9211A-A	二段式壓腳 Two-piece type presser foot

# V3

								
VC008A- VC008B-	04064P/VCE	4	8	1/4"(6.4mm)	1.4~3.6	12	UOX113GS #11~#14	4000
	04085P/VCE	4	8	1/3"(8.5mm)	1.4~3.6	12	UOX113GS #11~#14	4000
	04095P/VCE	4	8	3/8"(9.5mm)	1.4~3.6	12	UOX113GS #11~#14	4000
	04106P/VCE	4	8	5/12"(10.6mm)	1.4~3.6	12	UOX113GS #11~#14	4000
	04127P/VCE	4	8	1/2"(12.7mm)	1.4~3.6	12	UOX113GS #11~#14	4000



VC008B-04064P/VCE

## 褲頭鬆緊帶車縫

用於運動褲或運動短褲等圓筒型衣褲腰部鬆緊帶的包縫。本機型可有兩種縫合的方式：  
 (1)環型鬆緊帶布料折邊縫 (2)拷克後上環型鬆緊帶包縫

## ELASTIC INSERTING / ATTACHING





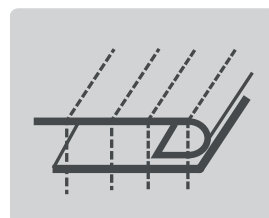
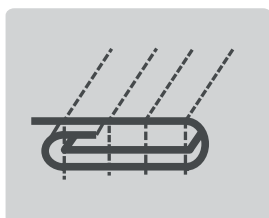

Inserting and attaching elastic on waistband of jogging suits, sportswears or shirts etc., two types of sewing functions are available :

1. To attach tubular seamless elastic waistband.
2. To cover sewing on elastic after overlock seaming.

選購配件	OPTIONAL DEVICE
	VAD , RL



# V4

								
VC008A-	04064P/VWL	4	8	1/4"(6.4mm)	1.4~3.6	12	UOX113GS #11~#14	4000
	04085P/VWL	4	8	1/3"(8.5mm)	1.4~3.6	12	UOX113GS #11~#14	4000
	04095P/VWL	4	8	3/8"(9.5mm)	1.4~3.6	12	UOX113GS #11~#14	4000
	04106P/VWL	4	8	5/12"(10.6mm)	1.4~3.6	12	UOX113GS #11~#14	4000
	04127P/VWL	4	8	1/2"(12.7mm)	1.4~3.6	12	UOX113GS #11~#14	4000

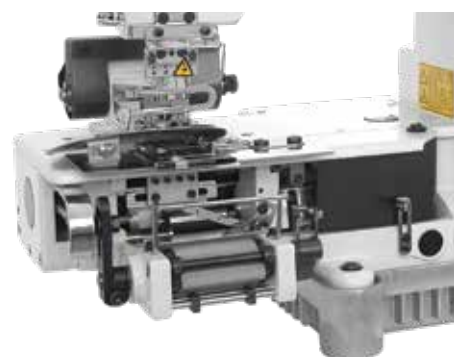

VC008A-04085P/VWL

## 褲頭鬆緊帶車縫 (附B413喇叭)

鬆緊帶送帶滾輪裝置能依據機台之運轉速度送帶，可準確控制鬆緊帶長度與鬆緊度。操作簡便，適用於慢跑褲、運動褲、男女內褲等褲頭之鬆緊帶車縫。

註：B413喇叭可用鬆緊帶尺寸為 38mm

## ELASTIC ATTACHING (WITH FOLDER B413)





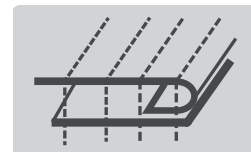

Elasticity and length feeding can be accurately controlled according to sewing speed of machine. Easy operation for elastic inserting and attaching on waistband of jogging pants, sportswears, briefs etc.

Remark : Elastic size 38mm for folder B413



選購配件	OPTIONAL DEVICE
	FH

# V5

							Needle No.	
VC008A-	04064P/VWLB	4	8	1/4"(6.4mm)	1.4~3.6	12	UOX113GS #11~#14	4000
	04085P/VWLB	4	8	1/3"(8.5mm)	1.4~3.6	12	UOX113GS #11~#14	4000
	04095P/VWLB	4	8	3/8"(9.5mm)	1.4~3.6	12	UOX113GS #11~#14	4000
	04106P/VWLB	4	8	5/12"(10.6mm)	1.4~3.6	12	UOX113GS #11~#14	4000
	04127P/VWLB	4	8	1/2"(12.7mm)	1.4~3.6	12	UOX113GS #11~#14	4000

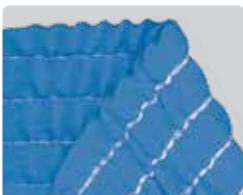
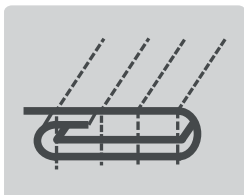

## 褲頭鬆緊帶車縫 (附B411喇叭及撐開滾輪組)

鬆緊帶送帶滾輪裝置能依據機台之運轉速度送帶，可準確控制鬆緊帶長度與鬆緊度，操作簡便，適用於慢跑褲、運動褲、男女內褲等褲頭之鬆緊帶車縫。







## ELASTIC INSERTING (WITH FOLDER B411 AND EXTENDING ROLLER)

Elasticity and length feeding can be accurately controlled according to sewing speed of machine. Easy operation for elastic inserting and attaching on waistband of jogging pants, sportswears, briefs etc.

喇叭尺寸 Folder Size	成品尺寸 Finished Size	鬆緊帶尺寸 Elastic Tape Size	適用機型 Applicable Model
B411	33 mm	31 mm	04095
B411P	30 mm	28 mm	04085
B411Q	42 mm	40 mm	04127
B411R	25 mm	23 mm	04064
B411S	36 mm	34 mm	04106

選購配件 OPTIONAL DEVICE
FH

# V6

							Needle No.	
VC008A-	04064P/VWLC	4	8	1/4"(6.4mm)	1.4~3.6	12	UOX113GS #11~#14	4000
	04085P/VWLC	4	8	1/3"(8.5mm)	1.4~3.6	12	UOX113GS #11~#14	4000
	04095P/VWLC	4	8	3/8"(9.5mm)	1.4~3.6	12	UOX113GS #11~#14	4000
	04106P/VWLC	4	8	5/12"(10.6mm)	1.4~3.6	12	UOX113GS #11~#14	4000
	04127P/VWLC	4	8	1/2"(12.7mm)	1.4~3.6	12	UOX113GS #11~#14	4000
	12048P/VWLC	12	24	3/16"(4.8mm)	1.4~3.6	12	UOX113GS #11~#14	4000
	12064P/VWLC	12	24	1/4"(6.4mm)	1.4~3.6	12	UOX113GS #11~#14	4000

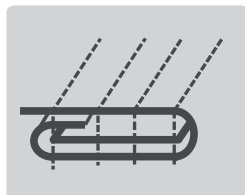

## 褲頭鬆緊帶車縫 (附VCE導片)

鬆緊帶送帶滾輪裝置能依據機台之運轉速度送帶，可準確控制鬆緊帶長度與鬆緊度，操作簡便，適用於慢跑褲、運動褲、男女內褲等褲頭之鬆緊帶車縫。





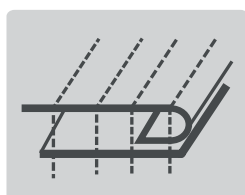

## ELASTIC INSERTING /ATTACHING (WITH VCE FABRIC GUIDE)

Elasticity and length feeding can be accurately controlled according to sewing speed of machine. Easy operation for elastic inserting and attaching on waistband of jogging pants, sportswears, briefs etc.



選購配件 OPTIONAL DEVICE
FH

V7

								
VC008A-	06048P/VPL	6	12	3/16"(4.8mm)	1.4~3.6	12	UOX113GS #11~#14	4000
VC008B-	06064P/VPL	6	12	1/4"(6.4mm)	1.4~3.6	12	UOX113GS #11~#14	4000



VC008B-06064P/VPL

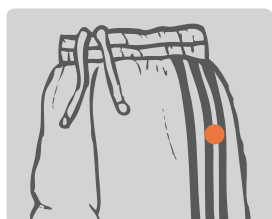

上帶車縫

適用於裝飾條帶、運動衣褲等車縫，效率高、品質穩定。

TAPE ATTACHING

Suitable for attaching ornament tape on sportswears.  
For high efficiency and perfect quality sewing.







選購配件 OPTIONAL DEVICE

LSA

若需要更高階機型，請參考  
ASV-ATS100A (P.16)  
For advanced model, please  
refer to ASV-ATS100 (P.16)



V8

								
VC008A-	12048P/VPQ	12	24	3/16"(4.8mm)	1.4~3.6	12	UOX113GS #11~#14	4000
	12064P/VPQ	12	24	1/4"(6.4mm)	1.4~3.6	12	UOX113GS #11~#14	4000



VC008A-12064P/VPQ

鬆緊帶抽皺縫裝置

適用於女皺折連身衣裙等腰邊鬆緊線皺折，如女用襯衫、游泳衣、枕頭套、兒童衫等  
均能車縫順暢。

注：勾針底線宜用彈性線





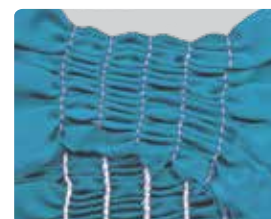
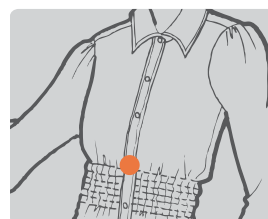

ELASTIC THREAD SHIRRING SEWING

Suitable for sewing ornamental shirring with elastic thread on women's blouses, swimsuits, dresses, pillowcases, and children's shirts etc.

Remark : Suggested to use elastic thread for lower looper



# V9

							Needle No.	
VC008A-	12048P/VPQ-K	12	24	3/16"(4.8mm)	1.4~3.6	12	UOX113GS #11~#14	4000
	12064P/VPQ-K	12	24	1/4"(6.4mm)	1.4~3.6	12	UOX113GS #11~#14	4000



VC008A-12048P/VPQ-K

## 鬆緊帶抽皺縫裝置

適用於女皺褶連身衣裙等腰邊鬆緊線皺褶，如女用襯衫、游泳衣、枕頭套、兒童衫等均能車縫順暢。

註：

1. 勾針底線宜用彈性線。
2. 增加VWL組可穩定彈性線的鬆緊度讓車縫更平順美觀，不跳針。
3. 將彈性線安裝於桌板下，讓彈性線車縫更順暢。
4. 本機為多功能車，可調為VWL、VPQ或一般車使用。

## ELASTIC THREAD SHIRRING SEWING





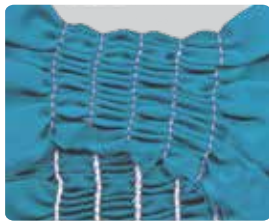
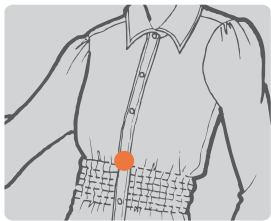

Suitable for sewing ornamental shirring with elastic thread on women's blouses, swimsuits, dresses, pillowcases, and children's shirts etc.

Remark :

1. Suggested to use elastic thread for lower looper.
2. The added VWL set will further stabilize the tension of elastic thread and make sewing process more smoothly, also can avoid stitch skipping.
3. Holds the elastic thread under the table to make sewing process more smoothly.
4. This is a multifunctional machine, can easily adjust to VWL, VPQ, or standard machine.



# V10

							Needle No.	
VC008A-	12048P/VPS	12	12	3/16"(4.8mm)	1.4~3.6	12	DV-K25 #18~21	4000
	12064P/VPS	12	12	1/4"(6.4mm)	1.4~3.6	12	DV-K25 #18~21	4000

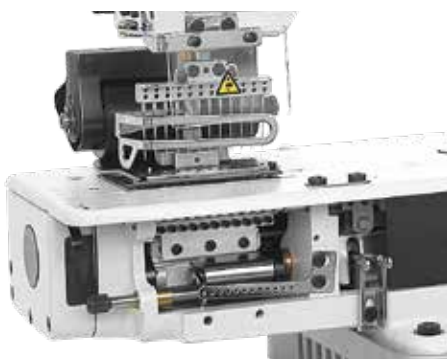

VC008A-12064P/VPS

## 鬆緊帶抽皺縫裝置

適用於女皺褶連身衣裙等腰邊鬆緊線皺褶，如女用襯衫、游泳衣、枕頭套、兒童衫等均能車縫順暢。

註：針線用彈性線，以勾針為勾線功能不穿線，為101車縫式樣





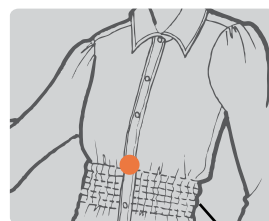

## ELASTIC THREAD SHIRRING SEWING

Suitable for sewing ornamental shirring with elastic thread on women's blouses, swimsuits, dresses, pillowcases, and children's shirts etc.

Remark : Needle uses elastic thread and looper without thread. It's 101 sewing type.





				 mm	 mm	 mm	Needle No.	 S.P.M. (Max)
VC008A-	12048P/VSC	12	36	3/16"(4.8mm)	1.4~3.6	12	UOX113GS #11~#14	2500
	12064P/VSC	12	36	1/4"(6.4mm)	1.4~3.6	12	UOX113GS #11~#14	2500

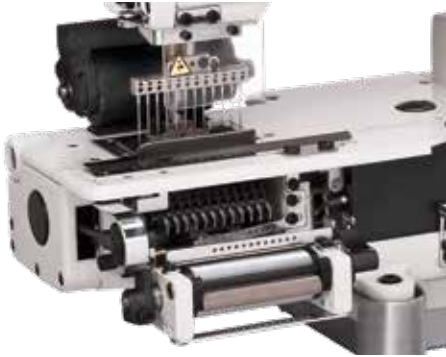

VC008A-12064P/VSC

### 鬆緊帶抽皺縫裝置

彈性線直送不打線圈，由針線與勾針線上下包覆，車縫成品效果較VPQ薄，且皺褶可拉伸至完全平坦。

### ELASTIC THREAD SHIRRING SEWING

Elastic thread is straight, not looped, which is fixed by needle thread and looper thread. The finish is thinner than VPQ and the shirring becomes flat as it is pulled extensively.

