

SIRUBA®

銀箭牌工業用縫紉機

INDUSTRIAL SEWING MACHINE

FA007

使用說明與零件圖 INSTRUCTION AND PARTS LIST

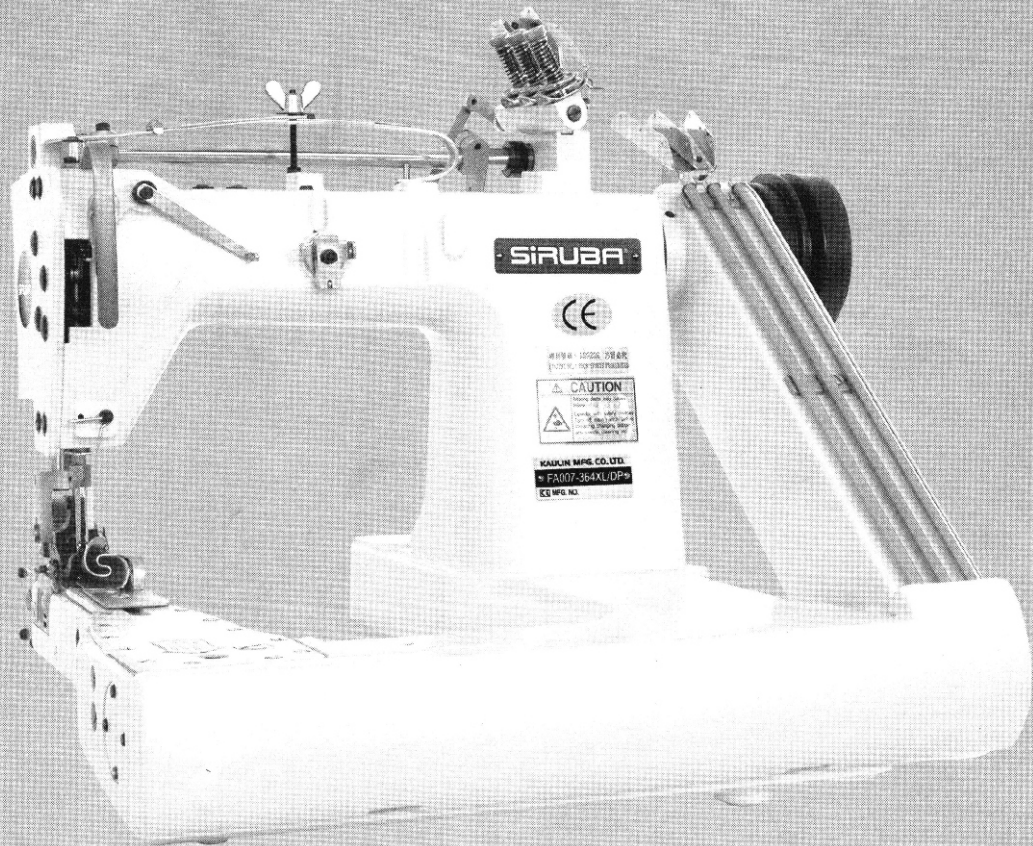

CE



高林股份有限公司
KAULIN MFG. CO., LTD.

CONTENTS

FEATURES	1
SPECIFICATIONS	2
TABLE OF STANDARD GAUGE	2
INSTALLING	3
1 Installing the Machine Head	3
2 Installing the Treadle and Chain	3
3 Installing the Motor Pulley	4
4 Belt Tension adjustment	4
5 Installing the Pulley Cover	4
6 Motor and Motor Pulley	4
7 Spool Stand	4
LUBRICATION AND RUNNING IN	4
1 Lubrication	4
2 Running In	5
CORRECT OPERATION	5
1 Needles and Threads	5
2 Installing the Needles	5
3 Upper Threading	6
4 Lower Threading	6
5 Installing the Lapper	7
6 Sewing	7
7 Thread Tension	7
8 Presser Foot Pressure Adjustment	8
9 Stitch Length Adjustment	8
10 Puller Feed Adjustment (Model 928-SP,-PL)	8
STANDARD ADJUSTMENTS	10
1 Needle and Looper Timing Adjustment	10
2 Needle Bar Height Adjustment	10
3 Looper Timing for Avoiding Contact with Needles	11
4 Needle Guard Adjustment	11
5 Feed Dog Height Adjustment	12
6 Puller Height Adjustment (Model 928-SP,-PL)	12
7 Installing the Spacer (For the denim specifications)	13
8 Upper Thread Take-up Thread Guide Adjustment	13
9 Thread Release Lever Adjustment	13
10 Thread Release Shaft Adjustment	14
11 Upper Thread Nipper Adjustment	14
12 Lower Thread Take-up Timing Adjustment	14
13 Puller Device Timing Adjustment (Model 928-SP,-PL)	14
TROUBLESHOOTING	15

FEA TURES

- ★Model FA007 Double Chain Stitch Feed-off-the-arm Machine is most suitable for sewing tubes of medium and heavy materials, such as those of jackets, denim trousers, fatigue clothes and work trousers.
- ★Machines made to the puller and denim specifications employ a presser foot, a needle plate, and feed dogs that have steps to prevent sewing irregularity and assure easy sewing of materials which may be different in thickness.
- ★Machines made to the puller and the denim specifications employ a movable needle guard which makes them ideal for sewing heavy materials.
- ★Machines made to the puller and the denim specifications have independent loopers for ease of adjustment.
- ★Machines made to the puller specifications employ a proximity puller system which assures outstanding feeding performance for a wide range of materials from medium heavy to heavy.

SPECIFICATIONS

Model	FA007-364 M	FA007-364 XL/SP		FA007-364 XL/DP	
Stitch pattern	3-line parallel sewing	2-line parallel sewing	3-line parallel sewing	2-line parallel sewing	3-line parallel sewing
Sewing speed	3,600 spm				
Stitch length	1.4~4.2mm	2~4.2mm			
No. of Needle	3	2	3	2	3
Needle gauge	$\frac{7}{64}$ $\frac{7}{64}$ (5.6mm) · $\frac{1}{8}$ $\frac{1}{8}$ (6.4mm) $\frac{5}{32}$ $\frac{5}{32}$ (8.0mm) · $\frac{3}{16}$ $\frac{3}{16}$ (9.6mm)	$\frac{3}{16}$ (4.8mm) $\frac{1}{4}$ (6.4mm)	$\frac{1}{8}$ $\frac{1}{8}$ (6.4mm) $\frac{5}{32}$ $\frac{5}{32}$ (8.0mm) $\frac{3}{16}$ $\frac{3}{16}$ (9.6mm)	$\frac{1}{4}$ (6.4mm)	$\frac{1}{8}$ $\frac{1}{8}$ (6.4mm) $\frac{5}{32}$ $\frac{5}{32}$ (8.0mm)
Needle bar stroke	33.4mm	35mm			
Minimum tube size	190mm				
Puller device	None	Equipped	Equipped	Equipped	Equipped

TABLE OF STANDARD GAUGE

Specification	Needle gauge	Needle clamp	Needle Plate	Presser foot	Feed dog	Looper assembly	Lapper		
Standard Specification	FA007-364 M	$\frac{7}{64}$ $\frac{7}{64}$	$\frac{7}{64}$ $\frac{7}{64}$	$\frac{7}{64}$ $\frac{7}{64}$	$\frac{7}{64}$ $\frac{7}{64}$	$\frac{1}{8}$ $\frac{1}{8}$	$\frac{7}{64}$ $\frac{7}{64}$	$\frac{7}{32}$ MH	
								$\frac{7}{32}$ H	
		$\frac{1}{8}$ $\frac{1}{8}$	$\frac{1}{8}$ $\frac{1}{8}$	$\frac{1}{8}$ $\frac{1}{8}$	$\frac{1}{8}$ $\frac{1}{8}$	$\frac{1}{8}$ $\frac{1}{8}$	$\frac{1}{8}$ $\frac{1}{8}$	$\frac{1}{8}$ $\frac{1}{8}$	$\frac{1}{4}$ MH
									$\frac{1}{4}$ H
		$\frac{5}{32}$ $\frac{5}{32}$	$\frac{5}{32}$ $\frac{5}{32}$	$\frac{5}{32}$ $\frac{5}{32}$	$\frac{5}{32}$ $\frac{5}{32}$	$\frac{5}{32}$ $\frac{5}{32}$	$\frac{5}{32}$ $\frac{5}{32}$	$\frac{5}{32}$ $\frac{5}{32}$	$\frac{5}{16}$ MH
									$\frac{5}{16}$ H
$\frac{3}{16}$ $\frac{3}{16}$	$\frac{3}{16}$ $\frac{3}{16}$	$\frac{3}{16}$ $\frac{3}{16}$	$\frac{3}{16}$ $\frac{3}{16}$	$\frac{3}{16}$ $\frac{3}{16}$	$\frac{5}{32}$ $\frac{5}{32}$	$\frac{3}{16}$ $\frac{3}{16}$	$\frac{3}{8}$ MH		
							$\frac{3}{8}$ H		
Denim Specification	FA007-364 XL /SP, DP	$\frac{1}{8}$ $\frac{1}{8}$	$\frac{1}{8}$ $\frac{1}{8}$	$\frac{1}{8}$ $\frac{1}{8}$	$\frac{1}{8}$ $\frac{1}{8}$	$\frac{1}{8}$ $\frac{1}{8}$	$\frac{1}{8}$ $\frac{1}{8}$	$\frac{1}{4}$ XL	
		$\frac{5}{32}$ $\frac{5}{32}$	$\frac{5}{32}$ $\frac{5}{32}$	$\frac{5}{32}$ $\frac{5}{32}$	$\frac{5}{32}$ $\frac{5}{32}$	$\frac{3}{16}$ $\frac{3}{16}$	$\frac{5}{32}$ $\frac{5}{32}$	$\frac{5}{16}$ XL	
		$\frac{3}{16}$ $\frac{3}{16}$	$\frac{3}{16}$ $\frac{3}{16}$	$\frac{3}{16}$ $\frac{3}{16}$	$\frac{3}{16}$ $\frac{3}{16}$	$\frac{3}{16}$ $\frac{3}{16}$	$\frac{3}{16}$ $\frac{3}{16}$	$\frac{3}{8}$ XL	

INSTALLING

1 Installing the Machine Head

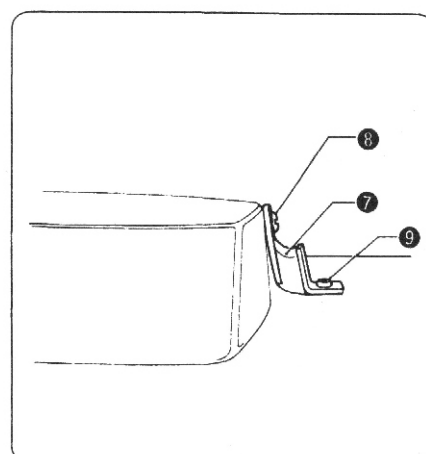
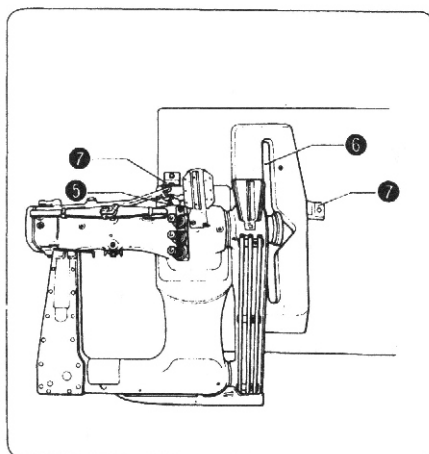
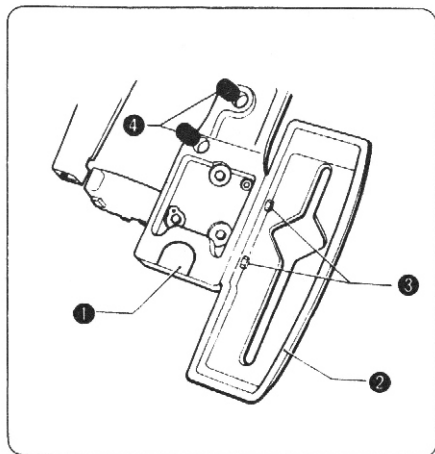

1. Install pulley cover base ② on machine bed ① with two hexagonal bolts ③.
2. Insert bar cushions ④ into the holes in the bottom of the bed.
3. Place the machine head on the table; adjust its position in forward and backward directions by aligning it with the hole for presser bar lifter chain ⑤, and in sidewise directions by aligning it with belt hole ⑥.
4. After fastening cushions ⑦ to the machine bed and pulley cover base with set screws ⑧, fix them to the table with screws ⑨.

2 Installing the Treadle and Chain

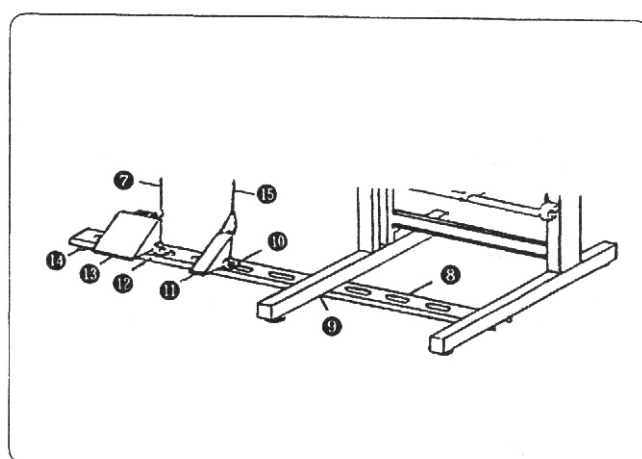
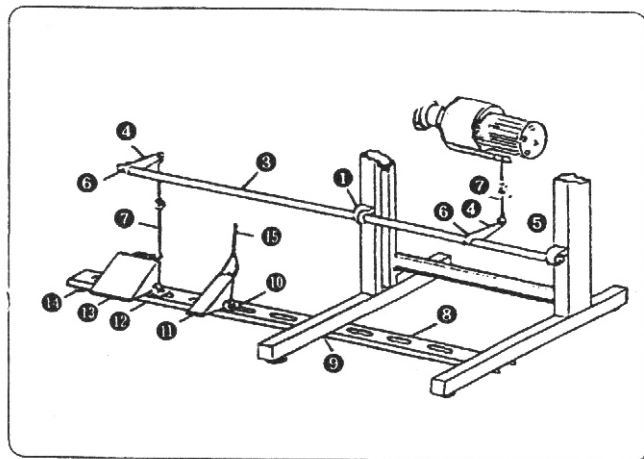

1. Fasten connecting lever bearing ① to the beam in the upper part of the table legs with nut ②.
2. Slide connecting lever L ④ onto connecting lever shaft ③, fit it to connecting lever bearing ①, and secure it with connecting lever shaft collar ⑤.
3. Set connecting lever L ④ in line with the clutch lever hole, and tighten it with square head bolts ⑥.
4. Hook connecting rod ⑦ to the clutch lever and connecting lever L ④.
5. Slide another connecting lever L ④ onto connecting lever shaft ③, and fix it with square head bolts ⑥.
6. Fasten treadle shaft ⑧ onto the lower beam across the table legs with hexagonal bolts ⑨.
7. Slide pedal stopper ⑩ and presser foot lifter pedal ⑪ onto treadle shaft ⑧, and fasten it with pedal stopper ⑩.
8. Slide treadle stopper ⑫ and treadle ⑬ onto treadle shaft ⑧, and fasten treadle stopper ⑫ in such a way that treadle ⑬ will move lightly.
9. Slide treadle support ⑭ onto the end of treadle shaft ⑧, turn it until treadle shaft ⑧ is parallel with the floor, and fasten it.
10. Hook one end of connecting rod ⑦ to connecting lever L ④, and hook the other end of it to treadle ⑬.
11. Hook one end of chain ⑮ to the presser foot lifter lever, pass the other end through the hole in presser foot lifter pedal ⑪, and adjust the chain length so that the pedal will be at the same height as treadle ⑬.

3 Installing the Motor Pulley

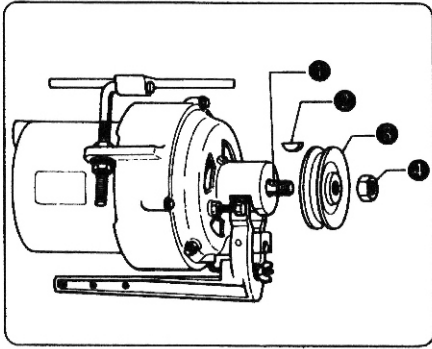

With motor shaft key way ① up, insert key ② into the key way, slide motor pulley ③ onto the motor shaft, and fasten it with nut ④.

4 Belt Tension Adjustment

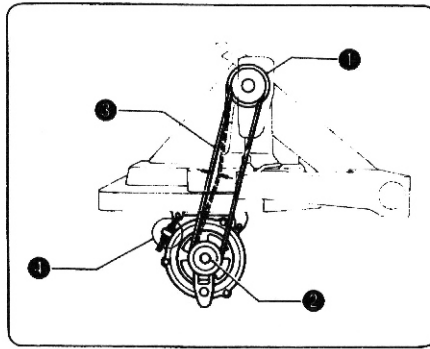

Place belt ③ on machine pulley ① and motor pulley ②, and adjust the belt tension with tension regulator ④ so that the belt sags about 25 to 30 mm when it is pressed with the thumb at the center point between the pulleys.

5 Installing the Pulley Cover

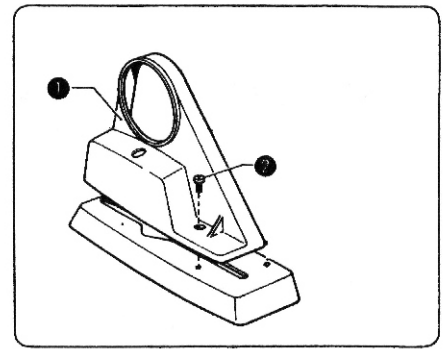

Install pulley cover ① on the pulley cover base with two set screws ②.

6 Motor and Motor Pulley

1. Use the motor specified below

Three-phase 200 V	2-pole, 400 W motor
-------------------	---------------------

2. Motor Pulley

Use the correct motor pulley suitable to the frequency of your power supply as specified below.

Frequency	Sewing speed	Motor pulley	Belt size
50Hz	3,100	85	M-45
	3,600	95	M-46
60Hz	3,100	70	M-44
	3,600	80	M-45

7 Spool Stand

Assemble spool stand ① as shown below, and install it at the right frontal corner of the table with screws.

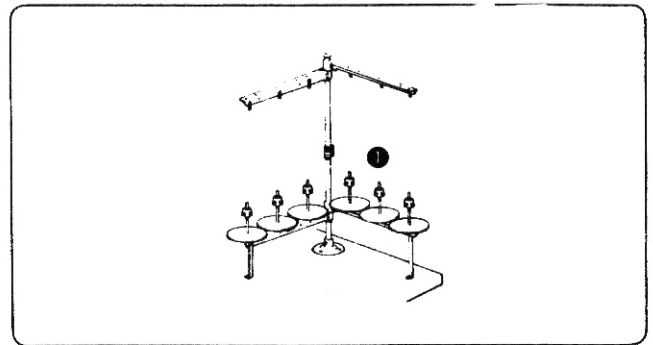

LUBRICATION AND RUNNING IN

1 Lubrication

Be sure to oil the following points before using your sewing machine.

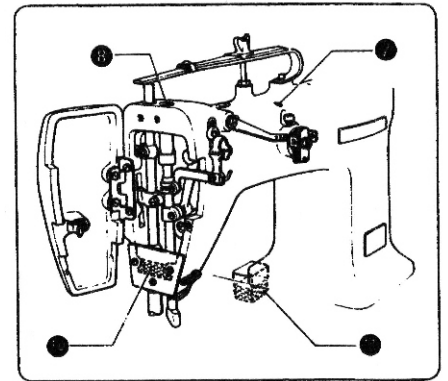
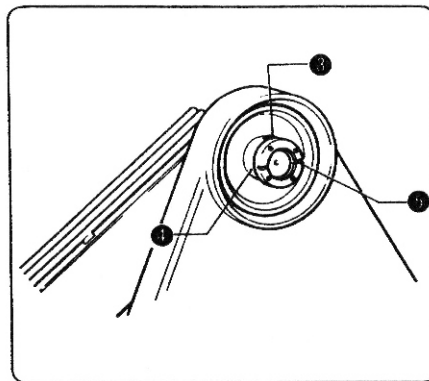
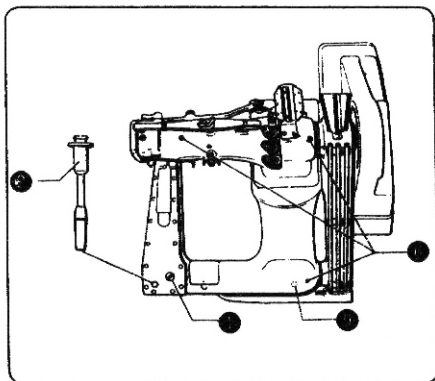

- After setting up the machine, remove adjusting cover screw ①, and pour oil in up to the reference line on oil gauge ②.
- Turn the pulley until oil cap ③ is up, remove oil cap ③ and pour oil into oil tank ④ until it is full. If the oil in the oil tank decreases below tank center line ⑤ the oil will not be drawn into the upper shaft, causing imperfect lubrication. Be sure to keep the oil in the oil tank above oil tank center line ⑤.
- Pour about 5 drops of oil weekly, into three oil cups ⑥, upper thread nipper tension bracket oil hole ⑦, and needle bar bushing oil hole ⑧.
- Remove oil drain screw ⑨ from time to time to discharge the used oil which has collected in the front bed oil sump.
- Wipe arm jaw ⑩ and rear bed oil sump ⑪ from time to time to remove oil from them.

※Use white spindle oil.

2 Running In

1. Motor switch on, depress the treadle, and make sure that the pulley runs in the arrow direction.
If the pulley runs in the opposite direction, remove the plug, and reconnect two of the three wires (but not the earth wire) of the 3-phase cord.
2. To run in your machine, operate it at about 3,100 spm for the first 3 or 4 days.

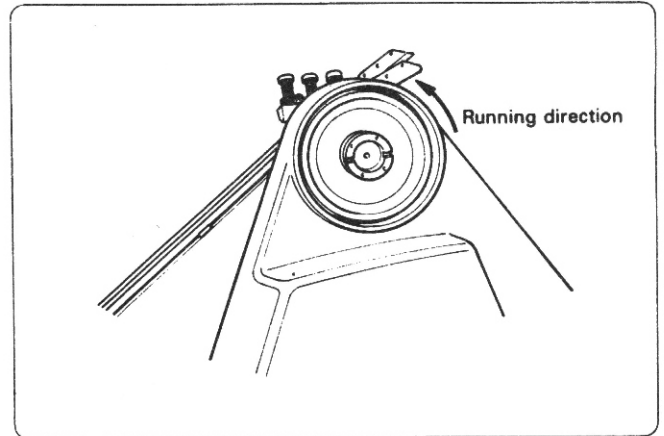

CORRECT OPERATION

1 Needles and Threads

The needle and threads to be used vary depending on sewing conditions. Select the correct ones by referring to the table below.

Needle	Thread	
	Upper thread	Lower thread
# 16	Cotton # 50	Cotton # 60
# 19	Cotton # 30	Cotton # 50
# 22	Cotton # 20	Cotton # 30

2 Installing the Needles

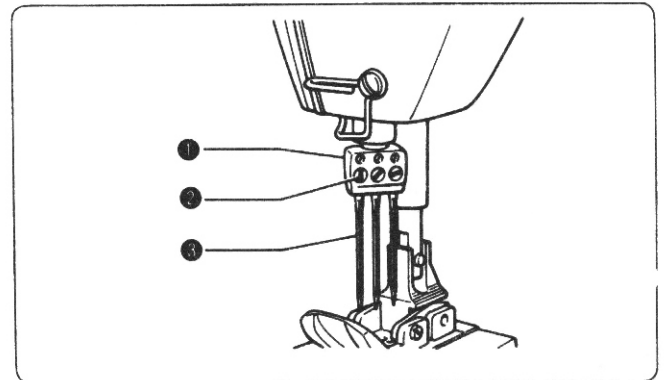

1. Turn the pulley until needle holder ❶ is raised to the highest position.
2. Loosen needle set screws ❷, hold needles ❸ with their long grooved side facing front, insert them into needle holder ❶ all the way, and fasten the needle with needle set screws ❷.

3 Upper Threading

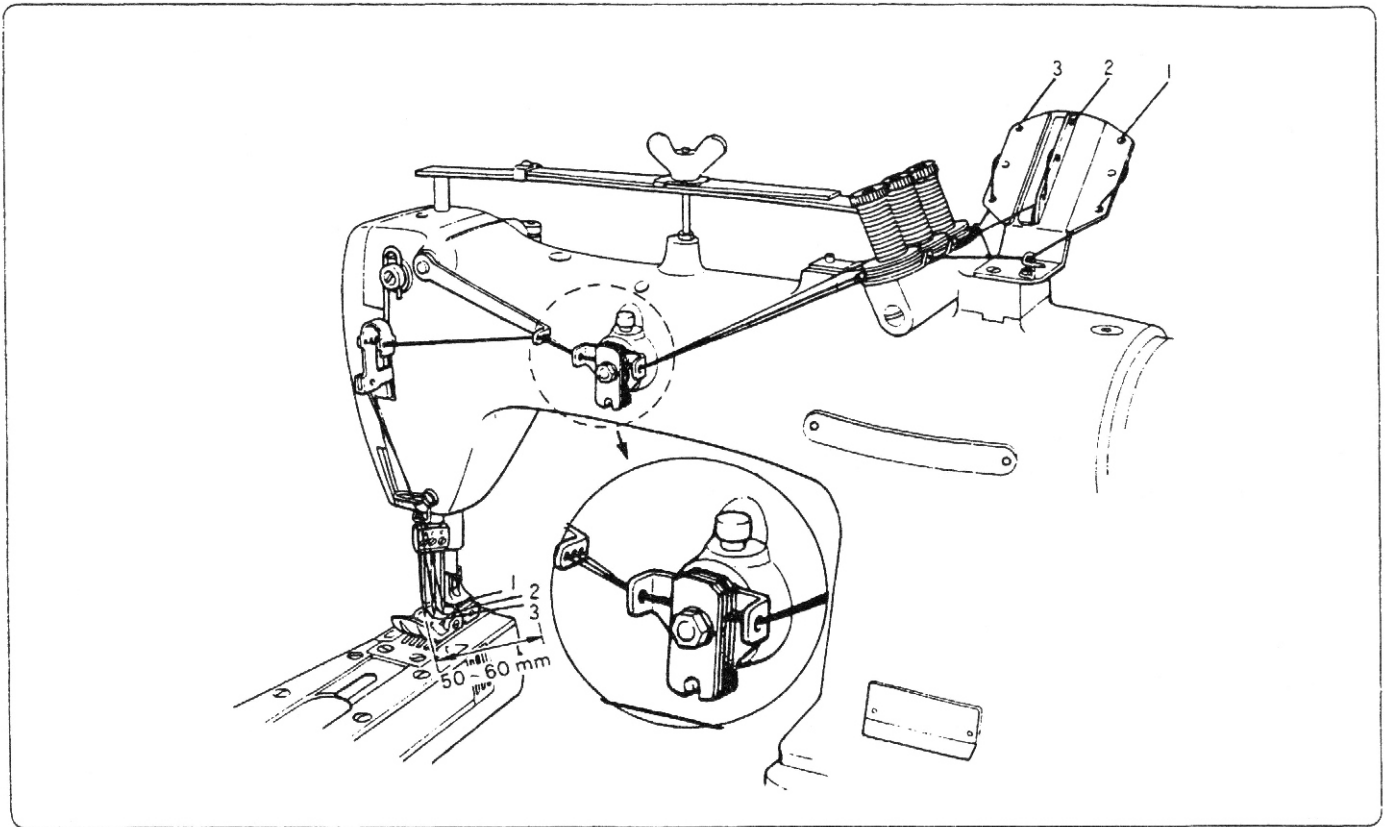

4 Lower Threading

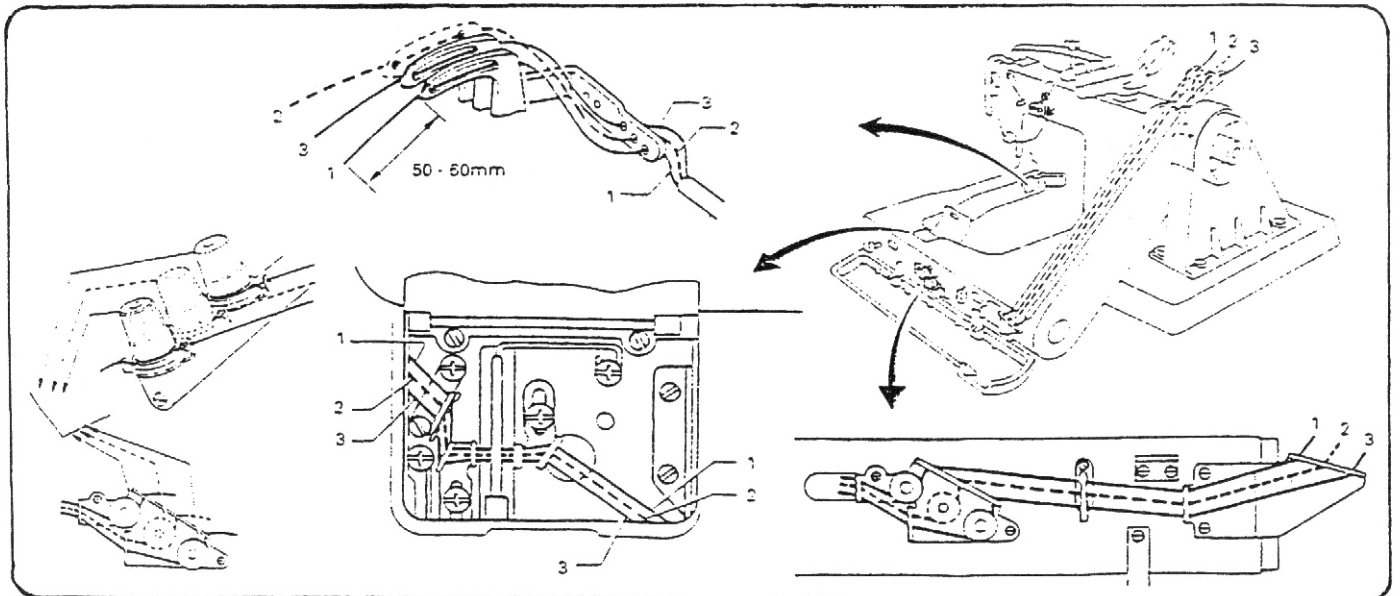

5 Installing the Lapper

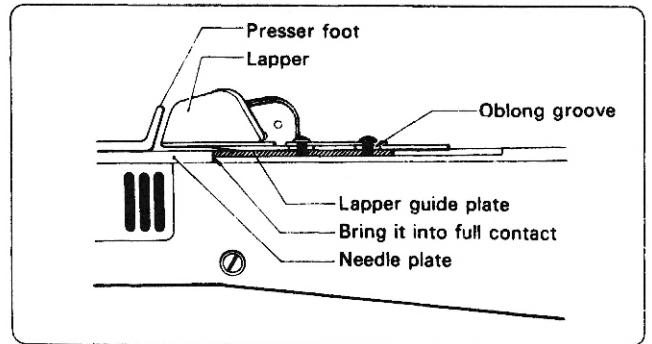
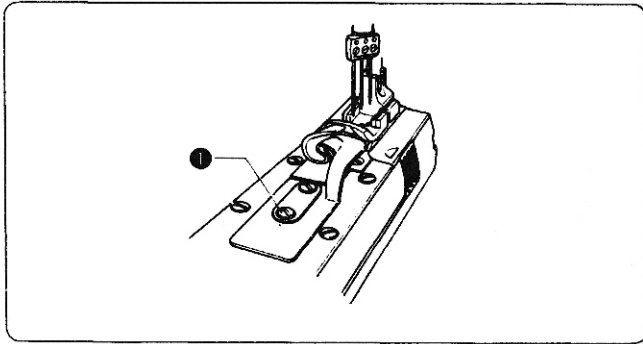

Insert the lapper guide plate into the oblong groove in the forward feed arm, and fit the lapper into place in such a way that its tip will not touch the presser foot.

※If the lapper is too hard to move, or fails to reach the correct position, loosen set screw ❶ slightly and adjust the lapper position.

6 Sewing

1. Switch the power on, step down on presser foot lifter pedal ❶, place a fabric under the presser foot, and release presser foot lifter pedal ❶.
2. Depress treadle ❷ to start the machine.
3. After sewing the work, keep sewing until it reaches thread cutter ❸, and then cut the threads with thread cutter ❸.

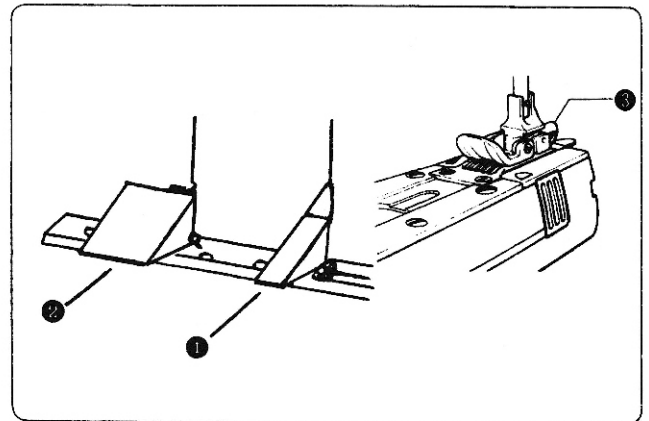

7 Thread Tension

Thread tension differs with sewing conditions. Adjust it to suit your particular sewing conditions.

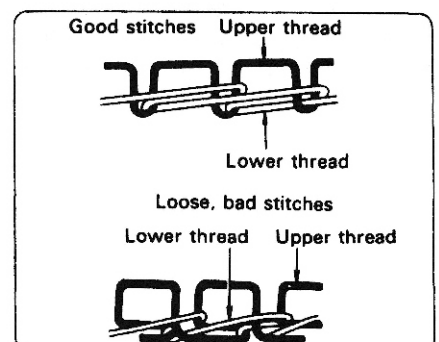
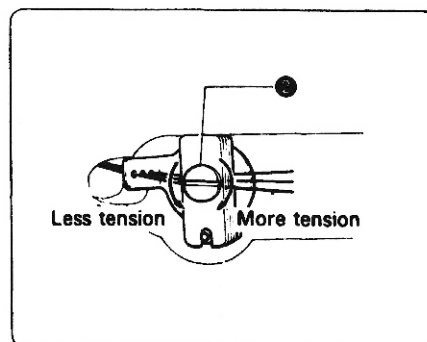
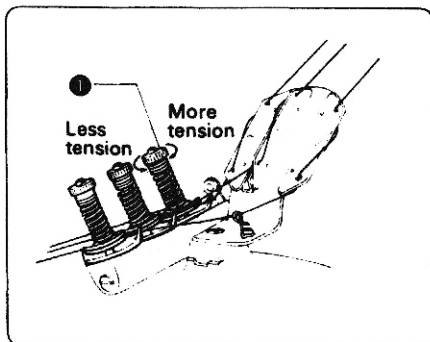

1. Adjust the upper thread tension properly by turning upper thread adjusting screw ❶.
2. Adjust the lower thread tension properly by turning lower thread adjusting screw ❷.

8 Presser Foot Pressure Adjustment

Adjust the presser foot pressure by turning wing nut ① to such a level that it is just enough to keep the work from slipping.

*In case of Model -SP and -DP, the puller pressure can be adjusted as appropriate to the work by loosening adjusting thumbscrew nut ② and turning presser adjusting screw ③.

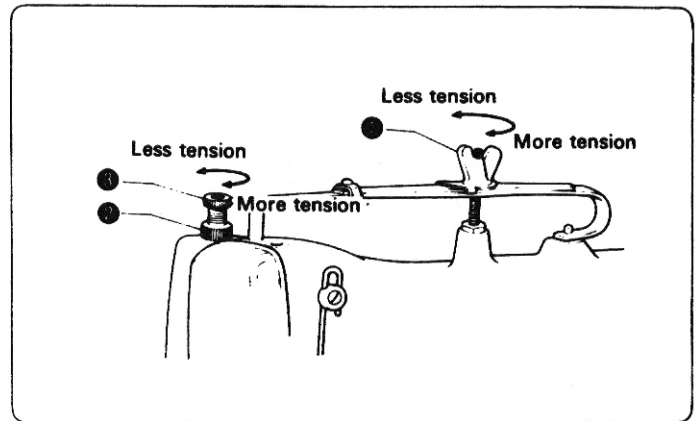

9 Stitch Length Adjustment

1. Remove adjusting cap screw ①.
2. Turn the pulley toward yourself until set screw ② comes to the position of the adjusting cap screw hole.
3. Loosen set screw ② with a screwdriver, turn the pulley again by about one-quarter of a turn in the same direction to bring horizontal eccentric adjusting screw ③ to the position of the adjusting cap screw hole.
4. Stitch length will decrease when horizontal eccentric adjusting screw ③ is turned clockwise with the screwdriver, and increase when it is turned counter-clockwise.
5. After the adjustment, tighten set screw ② securely.

*In case of Model -SP and -DP, readjust the needle guard after adjusting the stitch pitch. In case of Model -7A and -8A, readjust the needle guard and puller feed.

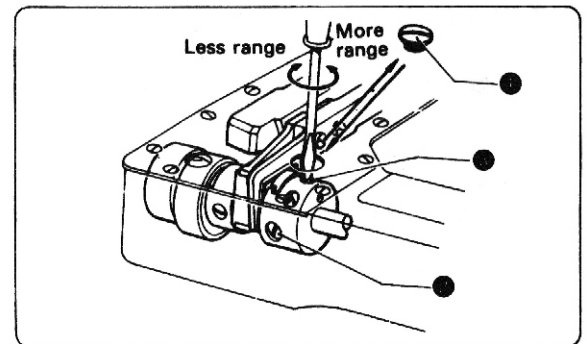

10 Puller Feed Adjustment (Model FA007-364 XL /SP , DP)

1. After adjusting the STITCH LENGTH, you have to readjust the PULLER FEED again.
2. Loosen the nut ①, you can get more feed toward outside, get less toward inside.
3. After adjusting, tighten the nut ①.

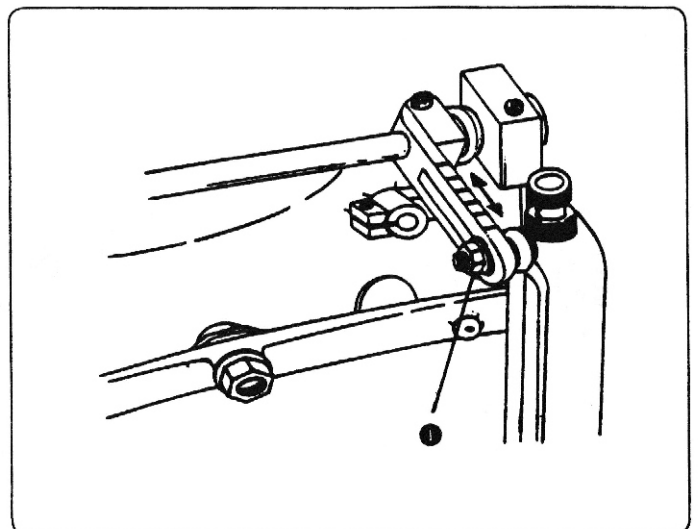

★The table below shows samples of stitches made with a highly elastic fabric and a fabric which is not so elastic.
Adjust the puller feed by referring to this table.

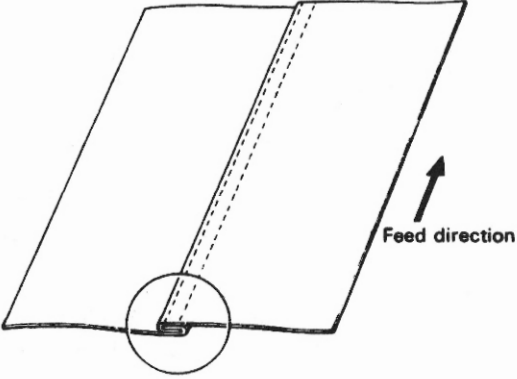
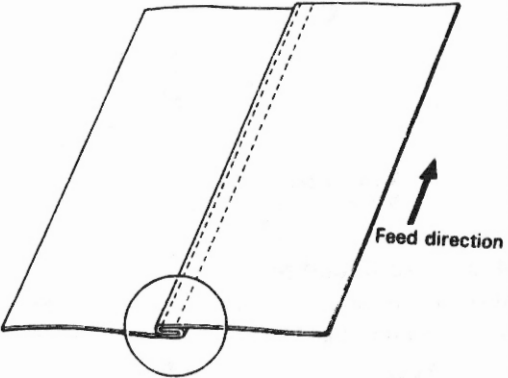
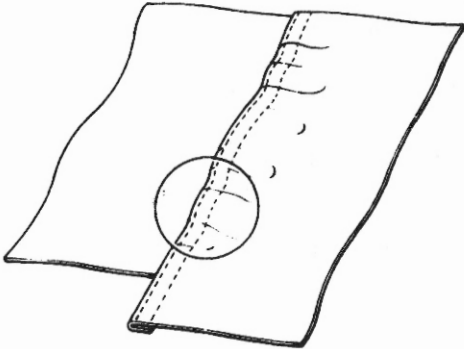
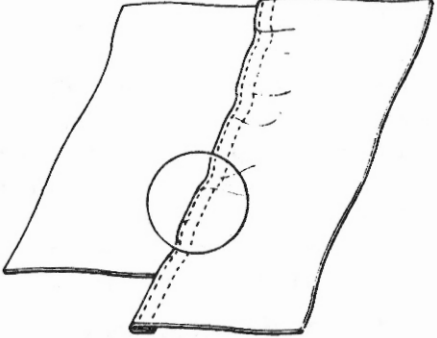
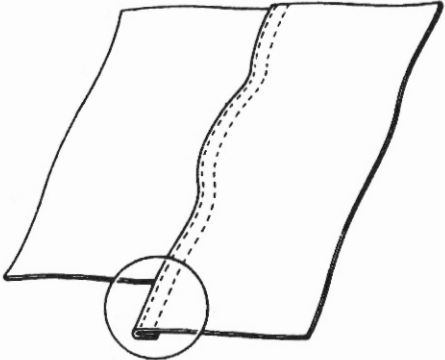
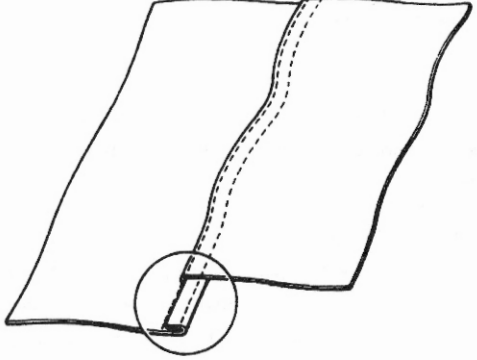
Puller feed	Fabric with high elasticity	Fabric with low elasticity
Correct	 <p data-bbox="389 781 868 808">Neither non-alignment nor sewing wrinkles.</p>	 <p data-bbox="971 781 1450 808">Neither non-alignment nor sewing wrinkles.</p>
Insufficient	 <p data-bbox="480 1384 772 1411">Non-aligned, and wrinkled.</p>	 <p data-bbox="1051 1384 1343 1411">Non-aligned, and wrinkled.</p>
Excessive	 <p data-bbox="464 1989 775 2016">Non-aligned, and very wavy.</p>	 <p data-bbox="1035 1989 1347 2016">Non-aligned, and very wavy.</p>

STANDARD ADJUSTMENTS

1 Needle and Loper Timing Adjustment

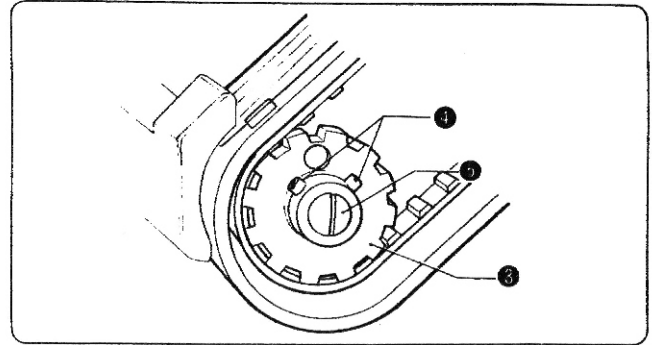
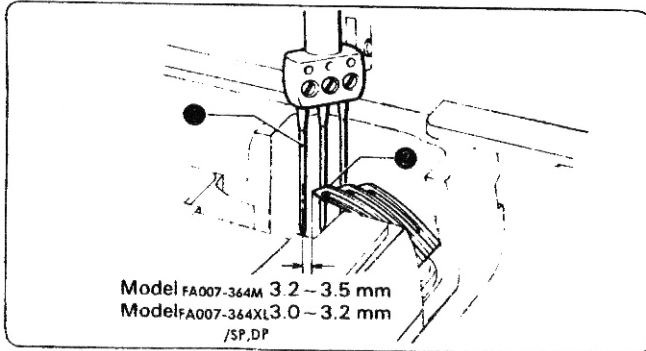

Model FA007-364 M

Make an adjustment so that, when needles ① come down to the lowest position, loopers ② will be at the end of their backward travel and that the distance between the centers of the needles and the tips of the loopers will be somewhere from 3.2 to 3.5 mm.

Model FA007-364 XL / SP , DP

Make an adjustment so that, when needles ① come down to the lowest position, loopers ② will be at the end of their backward travel and that the distance between the centers of the needles and the tips of the loopers will be somewhere from 3.0 to 3.2 mm.

<Adjusting Method>

1. Remove the presser foot, needle plate and feed dogs.
2. Loosen two set screws ④ and cap screw ⑤ on lower belt wheel ③.
3. Turn the pulley toward yourself until needles ① come down to the lowest position.
4. Turn the lower-shaft until loopers ② reach the end of their backward travel.
5. Tighten cap screw ⑤ and two set screws ④ securely.
6. Loosen set screw ⑥, move looper holder ⑦ in the arrow direction until the distance between the needle center and the looper tip is 3.2 to 3.5 mm, and retighten set screw ⑥ securely.

※In case of machines made to the denim specifications, the individual loopers must be adjusted because they are independent of one another.

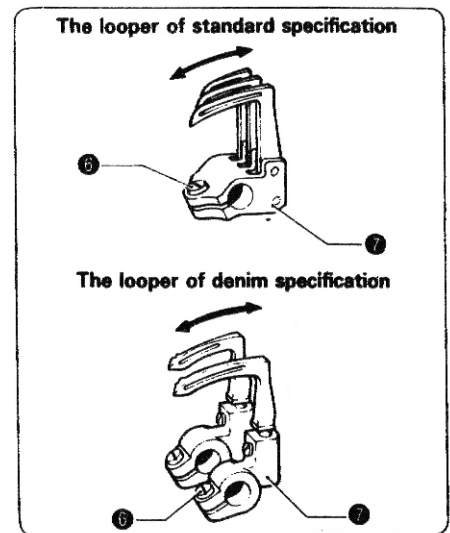

2 Needle Bar Height Adjustment

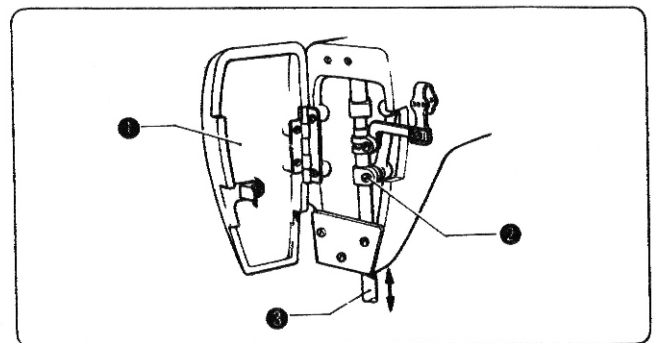
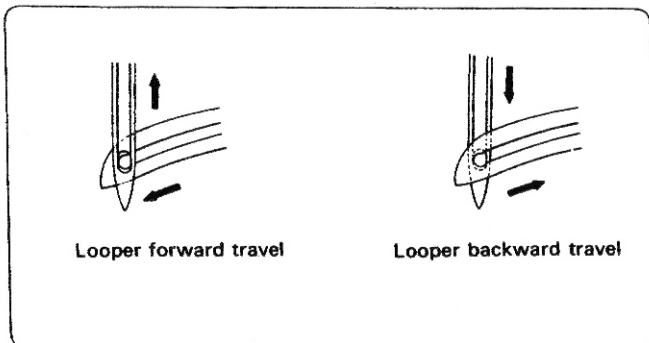

Adjust the needle bar height so that the looper thread eyes will match the needle eyes in the forward and backward travels of the loopers.

<Adjusting Method>

1. Turn the pulley toward yourself until the loopers move forward from the rightmost position to a point where the looper thread eyes are in line with the needles eyes.
2. Open face plate ①, loosen needle bar clamp screw ②, and move needle bar ③ up or down until the looper thread eyes are in line with the needle eyes.
3. Retighten needle bar clamp screw ② securely.
4. After the adjustment, turn the pulley toward yourself and make sure that the looper thread eyes match the needle eyes in the forward and backward travels of the loopers.

③ Looper Timing for Avoiding Contact with Needles

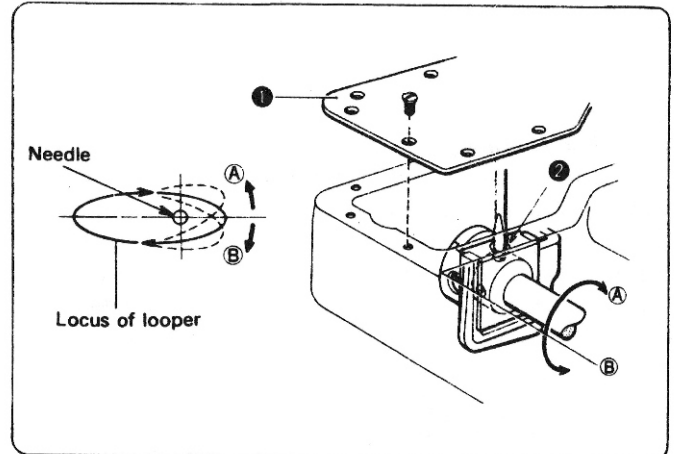
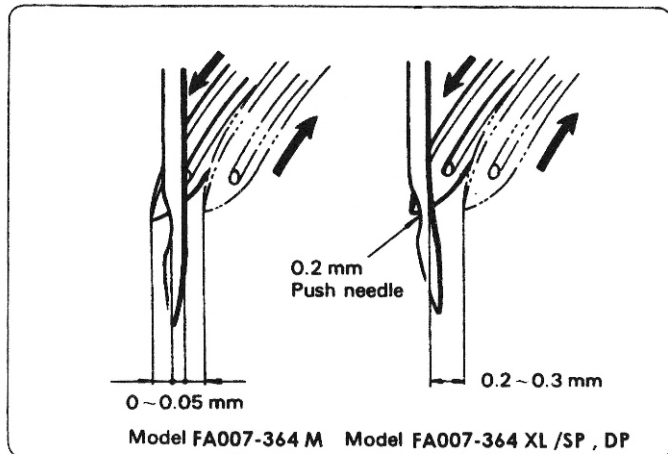

Model FA007-364 M

Make an adjustment so that there will be a clearance of 0 to 0.05 mm between the needles and the loopers in the forward and backward movements of the loopers.

Model FA007-364 XL / SP , DP

In the forward movement of the loopers, push needles by loopers by 0.2 mm. In the backward movement of the loopers, adjust that the clearance between the loopers and the needles will be 0.2 to 0.3 mm.

<Adjusting Method>

1. Remove forward feed arm cover ①, and turn the pulley toward yourself until the longitudinal eccentric wheel stop screw shows itself at adjusting hole ②.
2. Loosen the longitudinal eccentric wheel stop screw until it hardly comes out of the surface of the wheel, turn the pulley again toward yourself, and loosen the other stop screw.
3. With the screwdriver holding the stop screw, turn the pulley to adjust the clearance between the needles and the loopers.
4. After the adjustment, retighten the two stop screws and the forward feed arm cover screw.

④ Needle Guard Adjustment

Model FA007-364 M

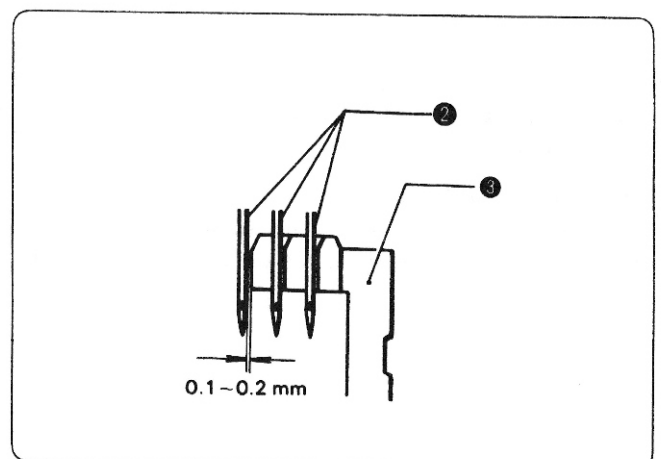
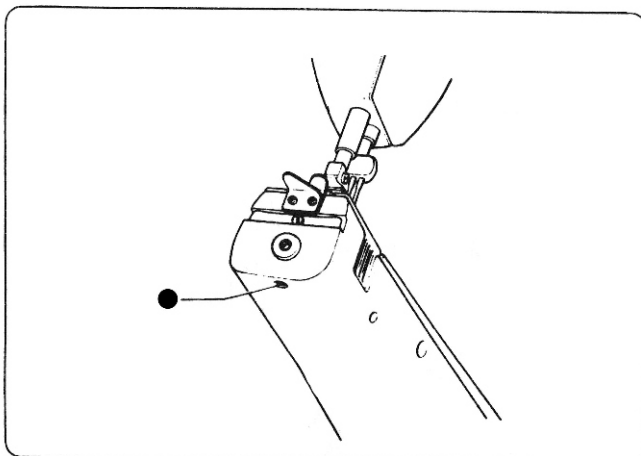

Make an adjustment so that, when the loopers meet the needles in their forward movement, there will be a clearance of 0.1 to 0.2 mm between the needles and the needle guard.

<Adjusting Method>

1. Turn the pulley toward yourself until the needles come down to the lowest position.
2. Loosen stop screw ② from the underside of the tip of the forward feed arm.
3. Adjust the clearance between needles ② and needles guard ③ to somewhere from 0.1 to 0.2 mm by moving needle guard ③.
4. After the adjustment, retighten stop screw ② securely.

Model FA007-364 XL /SP , DP

The clearance between the needles and the tips of the loopers will be 0.05 mm, pushing the needles by needle guard ①.

<Adjusting Method>

1. Turn the pulley toward yourself until the needles come down to the lowest position.
2. Loosen stop screw ②, and raise or lower needle guard ① so that the bottom ends of the needle eyes will be about 0.5 mm above the bottom of needle guard ①.
3. Turn the pulley toward yourself again until the tips of the loopers come to the centers of the needles.
4. Loosen stop screw ③, move needle guard ① to the left or to the right, and adjust so that the clearance between the needles and the tips of the loopers will be 0.05 mm, pushing needle points by needle guard ①. At this time, please make sure that the clearance between the loopers and the needles is 0.2~0.3 mm in the backward movement of the loopers.

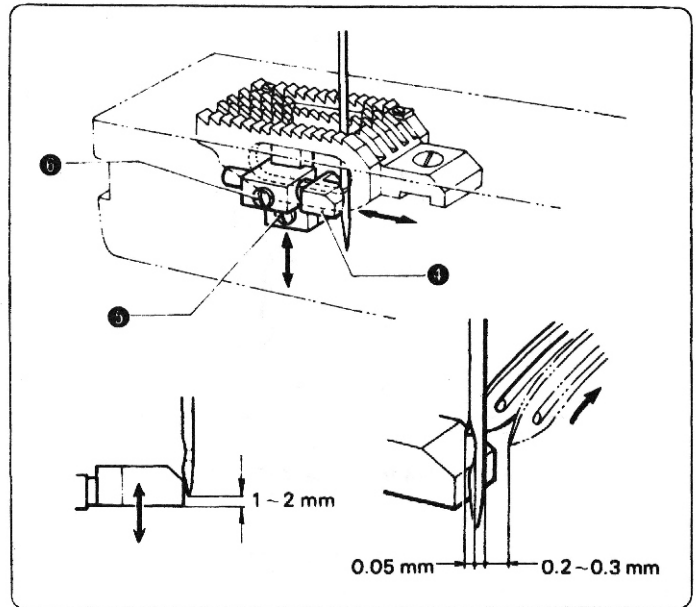

5 Feed Dog Height Adjustment

Model FA007-364 M

Make an adjustment so that, when feed dog ① is at the highest position, the feed dog will be 0.8 mm above the top surface of the needle plate.

Model FA007-364 XL /SP , DP

Make an adjustment so that the highest part of the feed dog will be 1.2 mm above the top surface of the needle plate.

<Adjusting Method>

Adjusting the feed dog height by turning feed base eccentric shaft ②.

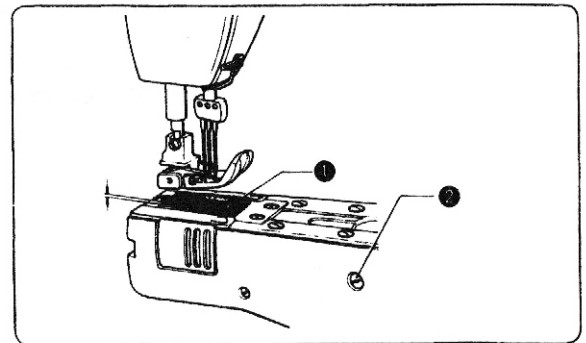

6 Puller Height Adjustment (Model FA007-364 XL /SP , DP)

Adjust the height of puller ① so that it is 0.1 to 0.2 mm high from the top of the needle plate.

<Adjusting Method>

Loosen set screw ②, and move puller support ③ up or down until puller ① is 0.1 to 0.2 mm above the top of the needle plate.

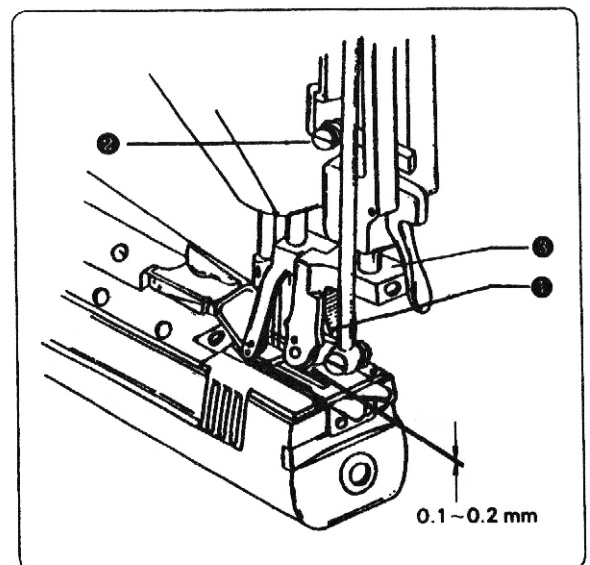

**7 Installing the Spacer
(For the denim specifications)**

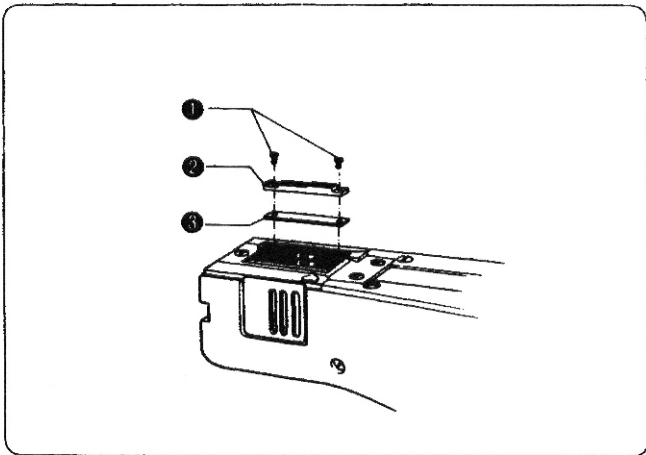

If stitch irregularities develop in sewing very heavy materials, adjust the sub-feed dog to the correct height by spacer.

(Adjusting Method)

1. Remove set screw ① and sub-feed dog ②.
2. Place spacer ③ under sub-feed dog ② and retighten set screw ①.

※The spacer is in the parts box.

8 Upper Thread Take-up Thread Guide Adjustment

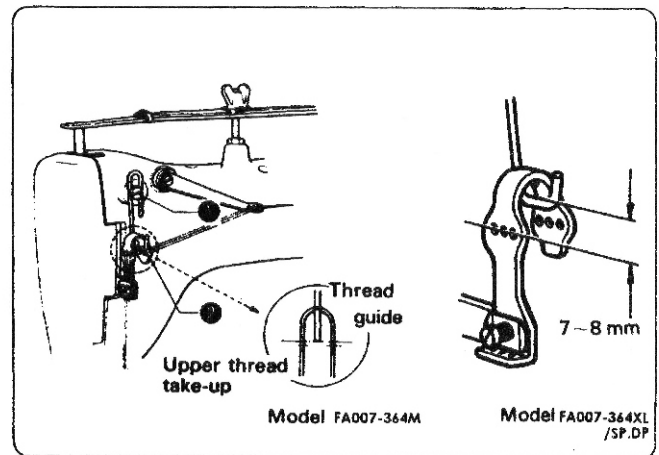

Model FA007-364 M

Make an adjustment so that, when the needle bar is down at the lowest position, the top of the upper thread take-up thread hole meets the bottom of the thread guide.

Model FA007-364 XL / SP , DP

Please adjust the distance between the center of the upper thread take-up and the top of the thread guide will be 7~8 mm.

(Adjusting Method)

1. Turn the pulley toward yourself until the needle bar is down at the lowest position.
2. Loosen set screw ①, and move upper thread take-up thread guide ② up or down until its bottom meets the top of the upper thread take-up thread hole.

※The higher the upper thread take-up thread guide ②, the greater will be the upper thread loops.

9 Thread Release Lever Adjustment

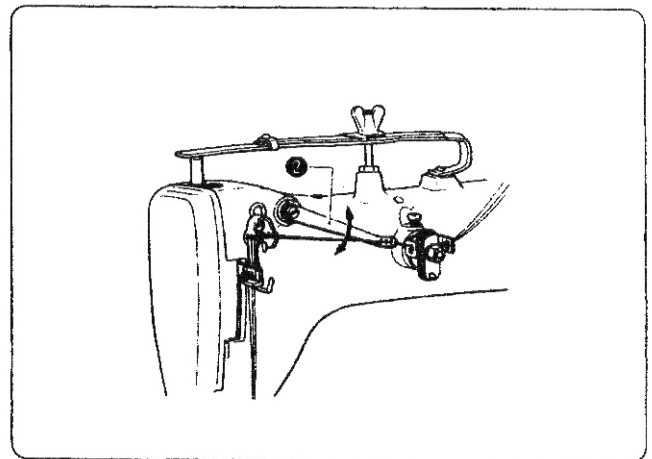
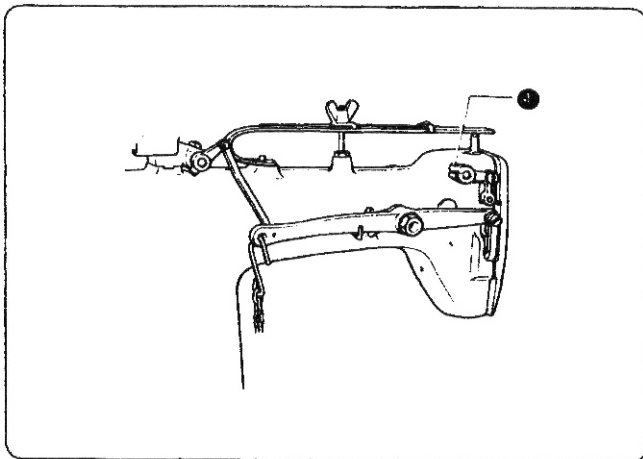

Make an adjustment so that, when the needle bar is down at the lowest position, the thread release lever thread hole meets the thread hole in upper thread tension bracket ①.

(Adjusting Method)

1. Turn the pulley until the needle bar is down at the lowest position.
2. Loosen set screw ①, and raise or lower thread release lever ② until its thread hole meets the thread hole in upper thread tension bracket ①.

※The higher the thread release lever, the tighter will be the stitches.

10 Thread Release Shaft Adjustment

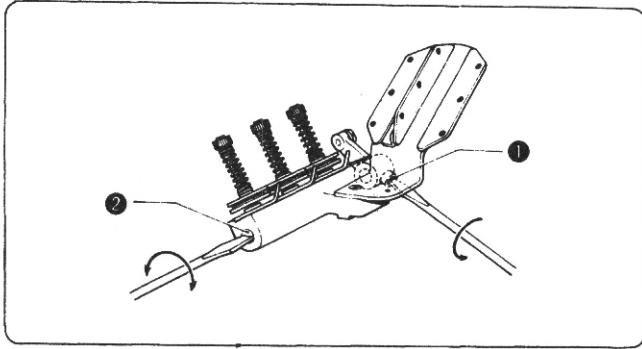

Make an adjustment so that the thread tension discs will loosen when the presser foot is raised, and tighten when the presser foot is lowered.

<Adjusting Method>

1. Loosen stop screw ①.
2. Make an adjustment by turning thread release shaft ② so that the thread tension discs will begin to loosen when the presser foot is raised 4 mm above the top surface of the needle plate.
3. After the adjustment, retighten stop screw ① securely.

12 Lower Thread Take-up Timing Adjustment

Make an adjustment so that, when the loopers begin to move backward, lower thread take-up ① will rise about 5 to 7 mm above lower thread take-up bracket ②.

<Adjusting Method>

1. Insert a screwdriver into the adjusting hole in the bed, and loosen two stop screws ③.
2. Raise lower thread take-up ① 5 to 7 mm above thread take-up bracket ②.
3. After the adjustment, retighten two stop screw ③.

11 Upper Thread Nipper Adjustment

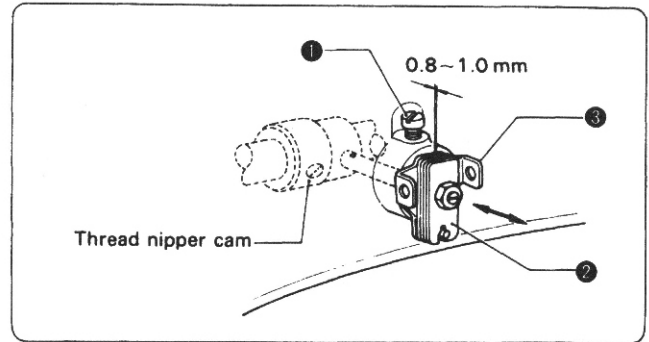

Adjust the clearance between the upper thread nipper tension bracket and tension plates to somewhere between 0.8 mm and 1.0 mm.

<Adjusting Method>

1. Loosen stop screw ①, and move upper thread nipper tension bracket ② in or out until the clearance between it and tension plates ③ is somewhere from 0.8 to 1.0 mm.
- *Stitch tightness can be improved by narrowing the clearance between upper thread nipper tension bracket ② and the arm.

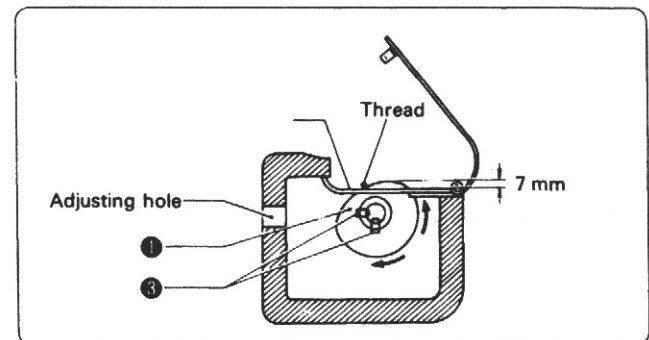

13 Puller Device Timing Adjustment (Model FA007-364 XL /SP , DP)

1. With 3mm wrench to loosen the screw ① & ②
2. The timing of the feed will be starting when the needle is away from the needle plate about 5 or 6mm, and stopping at 10mm.
3. After adjusting the timing, retighten the screw ① & ②.

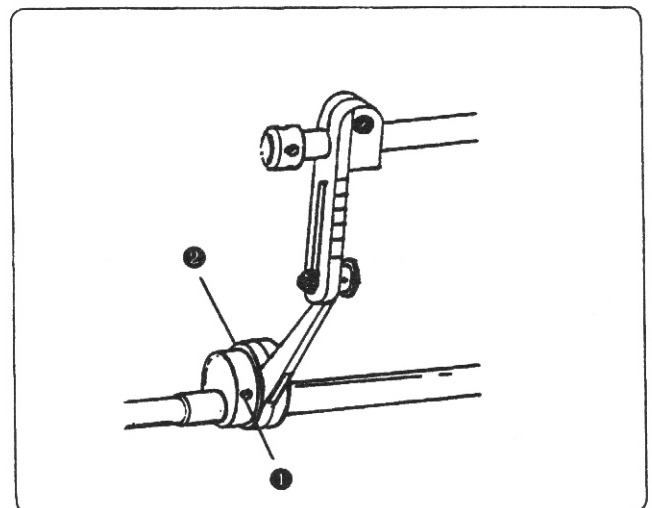

TROUBLESHOOTING

Trouble	Cause	Inspection	Remedy	Page
Thread breaks.	Needles installed improperly	Direction of long groove.	Refer to instructions for needle installing.	5
	Upper thread tension too great.	Upper thread tension.	Adjust upper thread tension.	7
	Lower thread tension too great.	Lower thread tension.	Adjust lower thread tension.	7
	Thread release lever out of position.	Thread release lever position.	Adjust thread release lever.	13
	Needle eyes too small for threads.	Needle size and thread count.	Refer to the section on "Needles and Threads"	5
	Loopers damaged.		Smooth loopers with sandpaper or buff.	/
Needles break.	Needles damaged.		Replace needles with good ones.	5
	Needles hit loopers.	Clearance between needles and loopers.	Adjust looper timing to avoid contact with needles.	11
	Needles installed improperly.	Direction of long groove.	Refer to instructions for needle installing.	5
	Needles hit needles guard.	Clearance between needles and needles guard.	Adjust needles guard.	11
	Needle eyes too small for threads.	Needle size and thread count.	Refer to the section on "Needles and Threads"	5
Stitches skip.	Needles installed improperly.	Direction of long groove.	Refer to instructions for needle installing.	5
	Looper points are dull.		Replace loopers with good ones.	10 11
	Needle and looper timing wrong.	Needle and looper timing.	Adjust needle and looper timing.	10
	Clearance between needles and loopers too great.	Clearance between needles and loopers.	Adjust clearance between needles and loopers.	11
	Lower thread take-up timing wrong.	Lower thread take-up timing.	Adjust lower thread take-up timing.	14
Upper threads loose.	Upper thread tension too small.	Upper thread tension.	Adjust upper thread tension.	7
	Lower thread tension too great.	Lower thread tension.	Adjust lower thread tension.	7
	Upper thread take-up thread guide out of position.		Adjust upper thread take-up thread guide position.	13
	Upper thread nipper does not tighten upper threads.	Tension plate clearance.	Adjust upper thread nipper.	14

Trouble	Cause	Inspection	Remedy	Page
Machine does not feed work.	Feed dog too low.	Feed dog height.	Adjust feed dog height.	12
	Presser foot pressure too small.	Presser foot pressure.	Adjust presser foot pressure.	8
	Feed dog worn out.		Have serviceman check it.	
	Presser foot floats and does not fully press work.		Have serviceman check it.	
	Feed dog and presser foot work on one side only.		Have serviceman check them.	
Non-alignment and wrinkles (Model - FA007-364M)	Sub feed dog height incorrect.	Sub feed dog height.	Adjust sub feed dog height.	13
	Presser foot pressure incorrect.	Presser foot pressure.	Adjust presser foot pressure.	8
	Feed dog height incorrect.	Feed dog height.	Ajust feed dog height.	12
Non-alignment and wrinkles (Model -FA007-364XL/SP,DP)	Puller timing wrong.	Puller timing.	Adjust puller device timing.	14
	Puller feed incorrect.	Puller feed.	Adjust puller feed.	8
	Presser foot pressure incorrect.	Presser foot pressure.	Adjust presser foot pressure.	8
	Feed dog height incorrect.	Feed dog height.	Adjust feed dog height.	12

CONTENTS 目錄

CO-MACHINE BODY.....	1
機體下拉布輪	
C1-UPPER SHAFT MACHANISM.....	3
上軸結構	
C2-NEEDLE BAR MECHANISM-FEED MECHANISM	5
針柱與送布傳動結構	
C3-PULLY MECHANISM.....	7
皮帶傳動結構	
C4- PRESSER BAR MECHANISM.....	9
壓腳柱結構	
C5-LOOPER MECHANISM.....	11
彎針傳動結構	
C6-UPPER THREADING MECHANISM.....	13
上導線張力結構	
C7-LOWER THREADING MECHANISM.....	15
下導線張力結構	
C8-LOWER SHAFT MECHANISM-GAUGE PARTS.....	17
下軸結構與針位組	
C9-GAUGE PARTS(SP) SP.....	19
針位組	
C10-GAUGE PARTS (DP) DP.....	21
針位組	
C11-PULLER DEVICE MECHANISM DP、SP.....	23
上拉布輪結構	
C12-ACCESSORIES.....	25
配件	

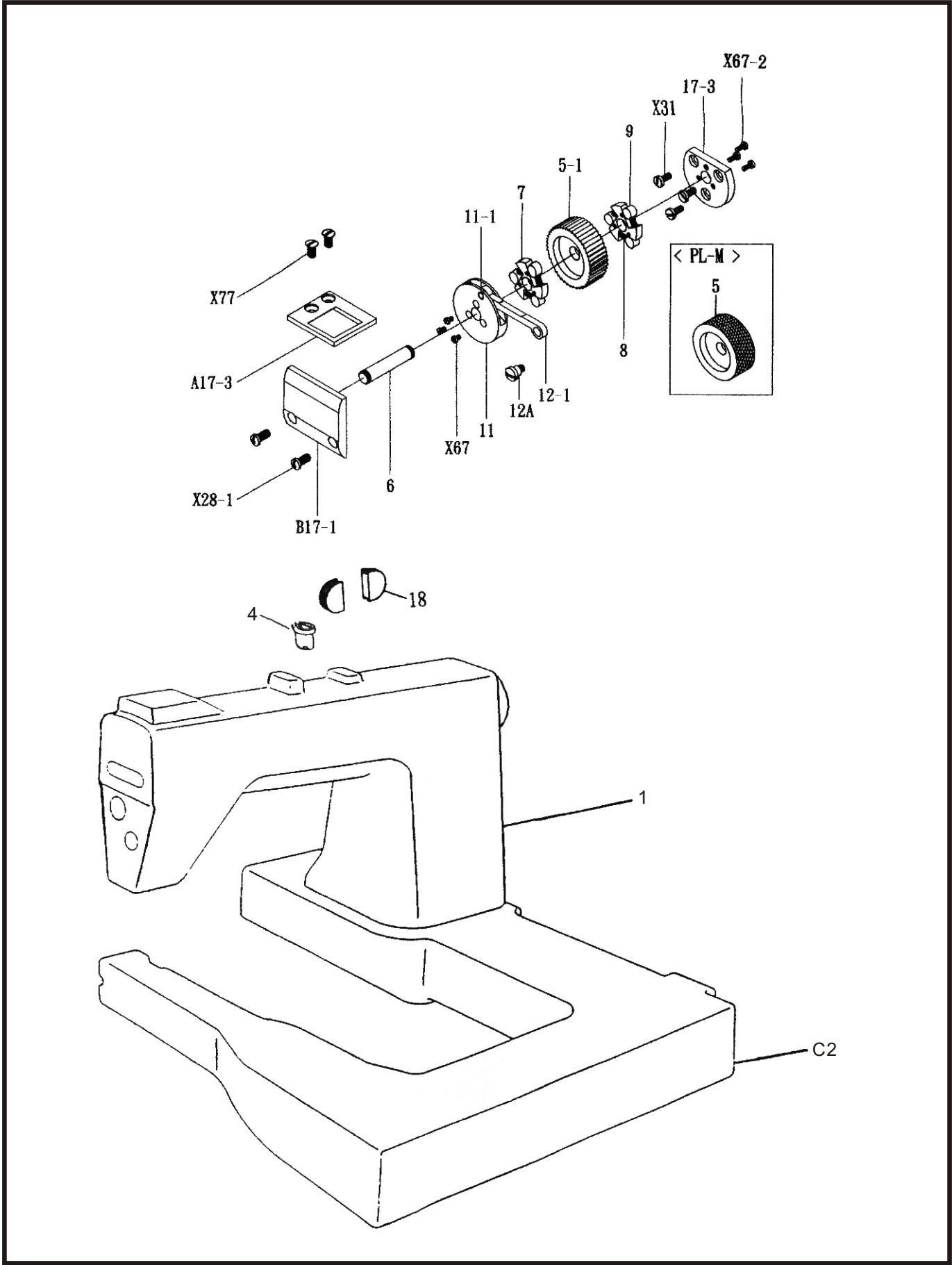

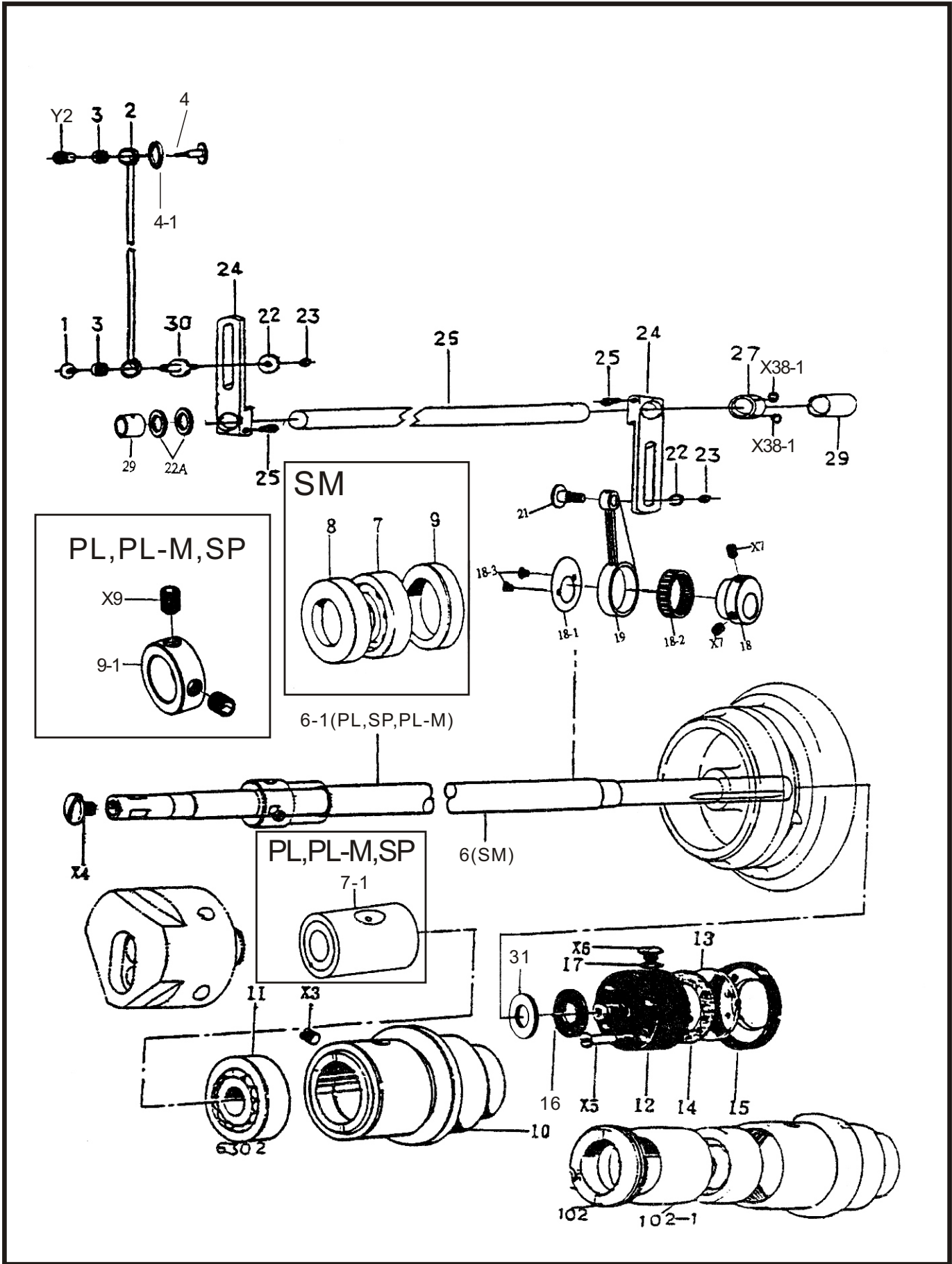

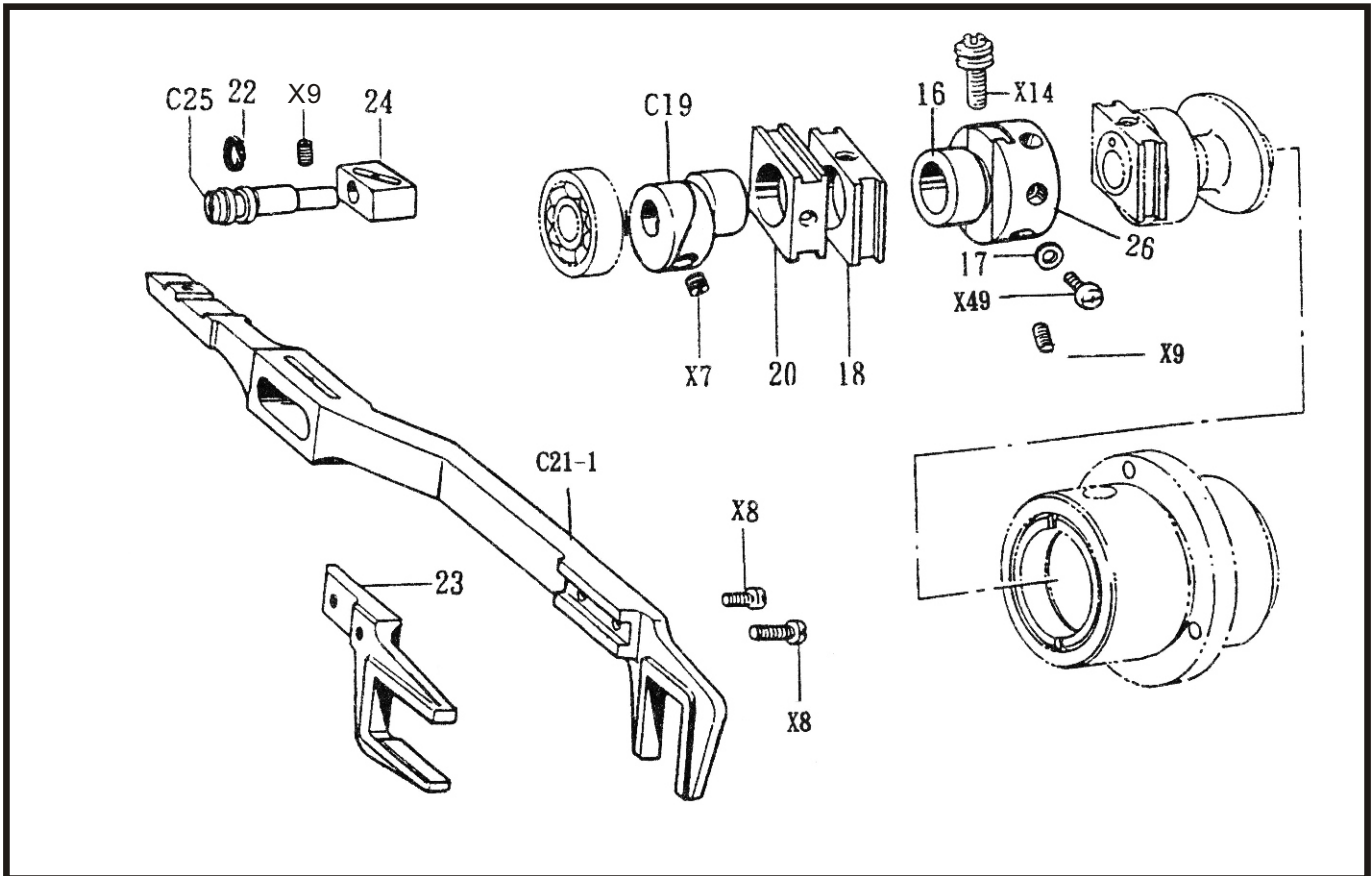
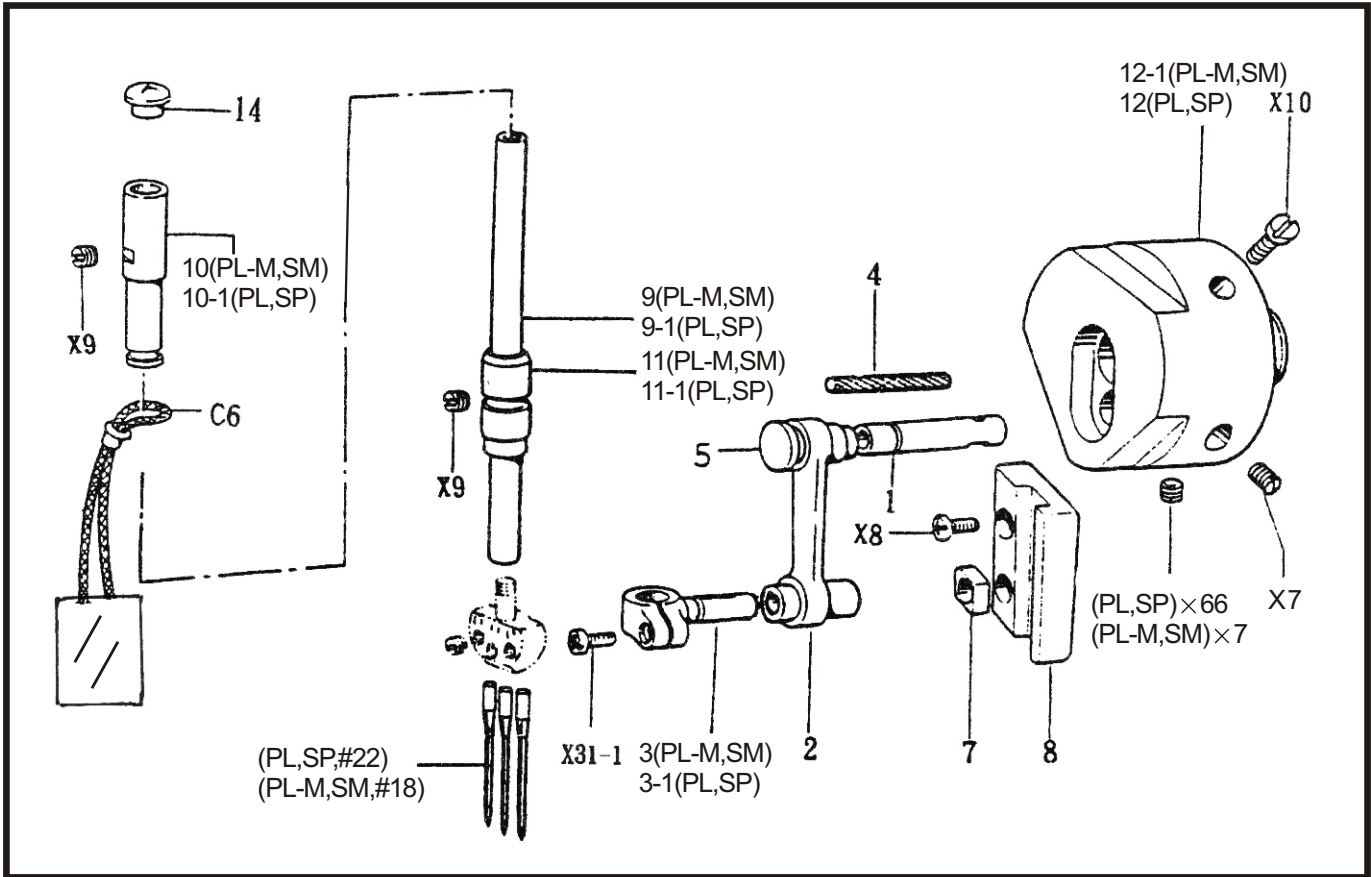

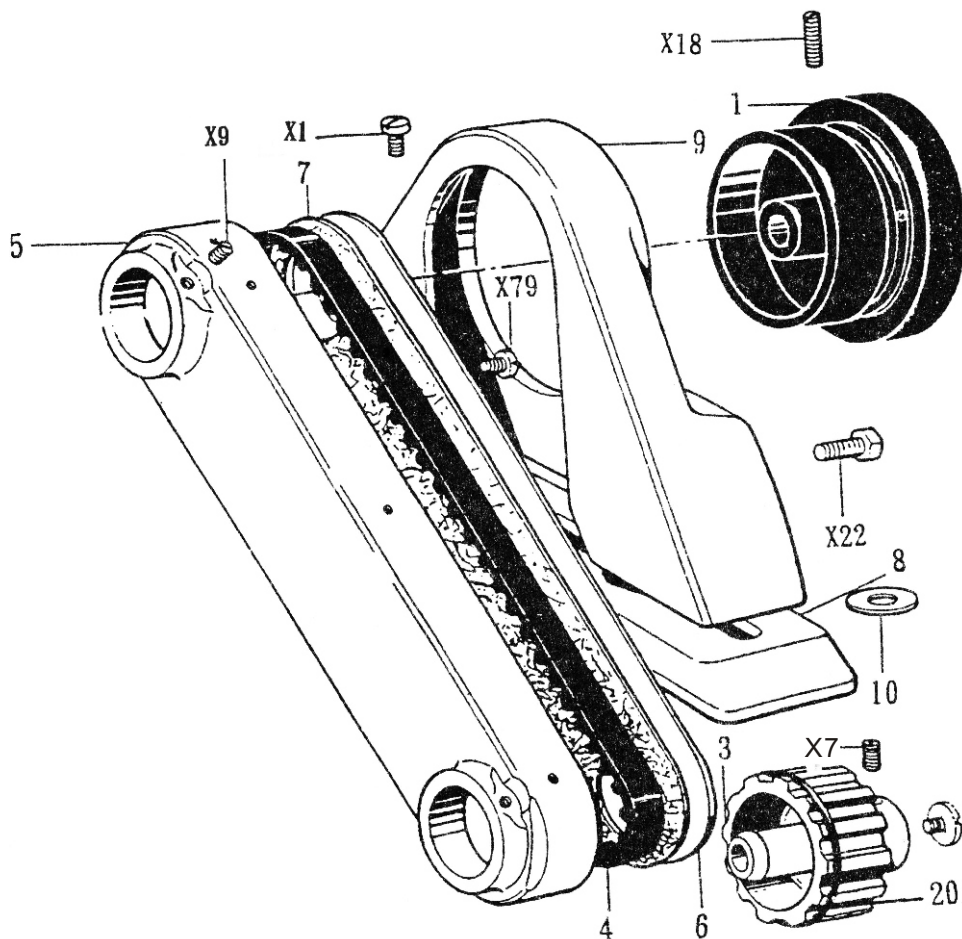
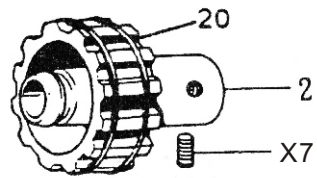

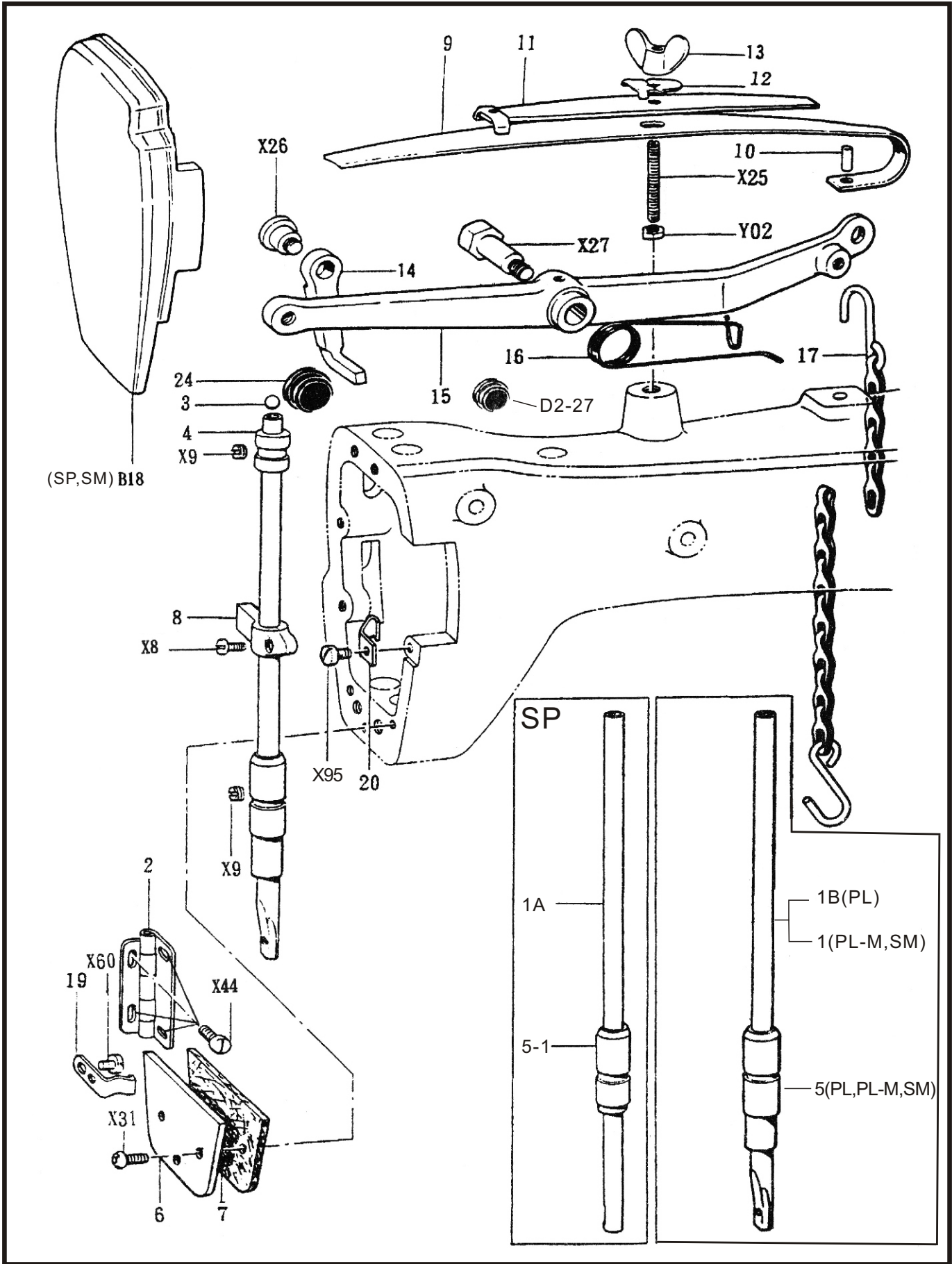

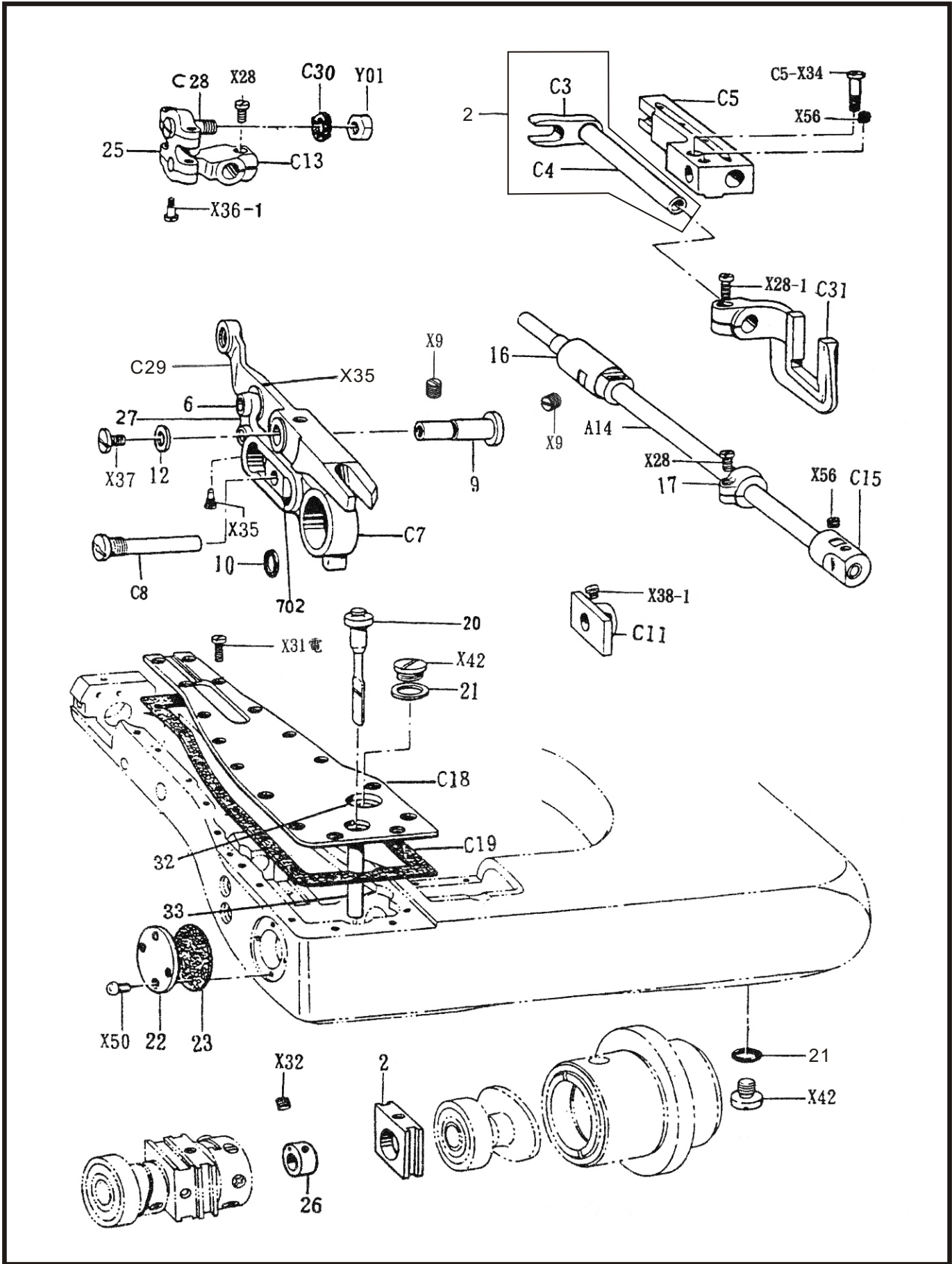

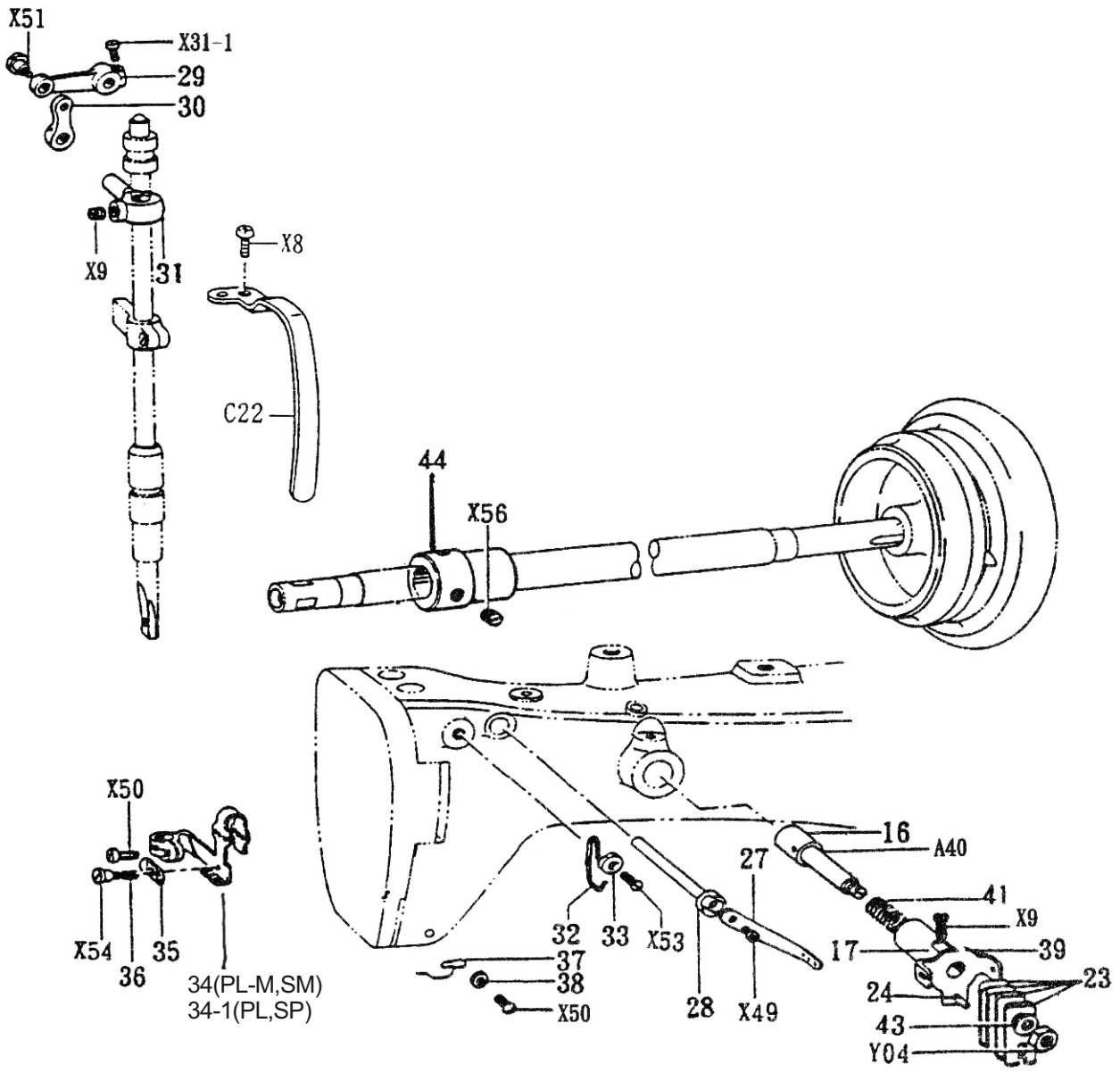
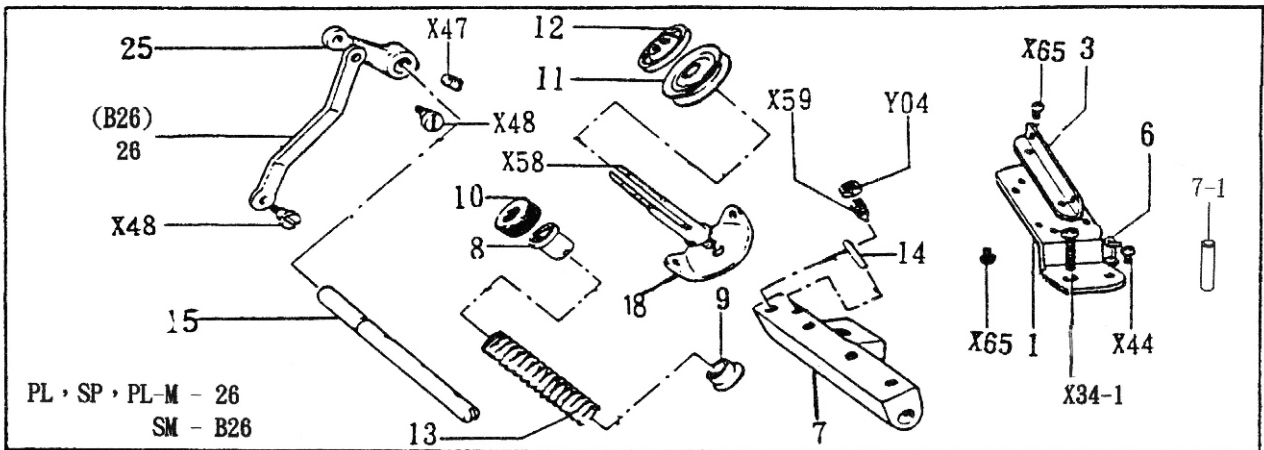

UPPER THREADING MECHANISM

REF. NO. 部件編號	NAME OF PARTS 說明	Amt req 需求量
C6-01	UPPER THREAD GUIDE RETAINER 上導線座	1
C6-03	BRACKET 過線片	1
C6-06	THREAD HANGER 導線圈	1
C6-07	LINE GUIDE DEVICE 倒位基座	1
C6-7-1	PIN 銷	1
C6-08	TENSION SPRING WASHER 彈簧墊圈	3
C6-09	TENSION SPRING WASHER 彈簧墊圈	3
C6-10	NUT 螺母	3
C6-11	TENSION DISC 沙拉片	6
C6-12	TENSION DISE PRESSER 張力墊圈	3
C6-13	UPPER THREAD TENSION SPRONG 張力彈簧	3
C6-14	UPPER THREAD RELEASE PIN 銷	1
C6-15	THREAD RELEASER SHAFT 轉軸	1
C6-16	--	
C6-17	--	
C6-18	UPPER THREAD TENSION SUTD SCREW 過線固定片	3
C6-23	LOWER THREAD TENSION PLATE 張力夾線片	4
C6-24	PIN 銷	1
C6-25	TENSION RELEASE CRANK 連桿	1
C6-26	TENSION RELEASE CONNECTING BAR 上線鬆放提柄	1
C6-27	THREAD RELEASER LEVER 撥線片	1
C6-28	THREAD RELEASER LEVER SAFT 撥線軸	1
C6-29	TENSION RELEASE CONNECTING ROD 連桿	1
C6-30	TENSION RELEASE LINK 小連柄	1
C6-31	TENSION RELEASE SUTD 壓腳柱夾	1
C6-32	THREAD GUIDE 導線勾	1
C6-33	WASHER 墊圈	1
C6-34	UPPER THREAD TAKE-UP LEEVER ASSEMBLY 天秤	1
C6-34-1	UPPER THREAD TAKE-UP LEEVER ASSEMBLY 天秤	1
C6-35	THREAD CHECKER 天秤夾線片	1
C6-36	SPRING 彈簧	1
C6-37	LOWER THREAD GUIDE 導線勾(D)	1
C6-38	WASHER 墊圈	1
C6-39	UPPER THREAD TENSION REGULATOR ASSEMBLY ?通導線片	1
C6-A40	UPPER THREAD TENSION SUTD ASSEMBLY 張力調節軸	1
C6-41	UPPER THREAD TENSION SPRING 彈簧	1
C6-43	WASHER 墊圈	1
C6-44	UPPER THREAD FASTENING CAM WITH SCREW 上線張力凸輪	1
C6-X8	SCREW 9/64x40 螺釘	2
C6-X9	SCREW 15/64x28 螺釘	1
C6-X31-1	SCREW 9/64x40 螺釘	1
C6-X34-1	SCREW 11/64x40 螺釘	2
C6-X44	SCREW 9/64x40 L=5 螺釘	1
C6-X47	SCREW 11/64x40 螺釘	1
C6-X48	SCREW 9/64x40 螺釘	2
C6-X49	SCREW 9/64x40 L=6 螺釘	1
C6-X50	SCREW 9/64x40 螺釘	1
C6-X51	SCREW 11/64x40 螺釘	1
C6-X53	SCREW 9/64x40 螺釘	1
C6-X54	SCREW 3/32x56 螺釘	1
C6-X56	SCREW 15/64x28 螺釘	2
C6-X58	UPPER THREAD TENSION STUD SCREW 叉口合葉螺釘	3
C6-X59	SCREW 11/64x40 螺釘	1
C6-X65	SCREW 3/32x56 L=4 螺釘	2
C6-B26	TENSION RELEASE CONNECTING BAR 上線鬆放提柄	2
C6-C22	THREAD TAKE-UP COVER 天秤護蓋	1
C6-Y04	NUT 11/64x40 螺釘	1

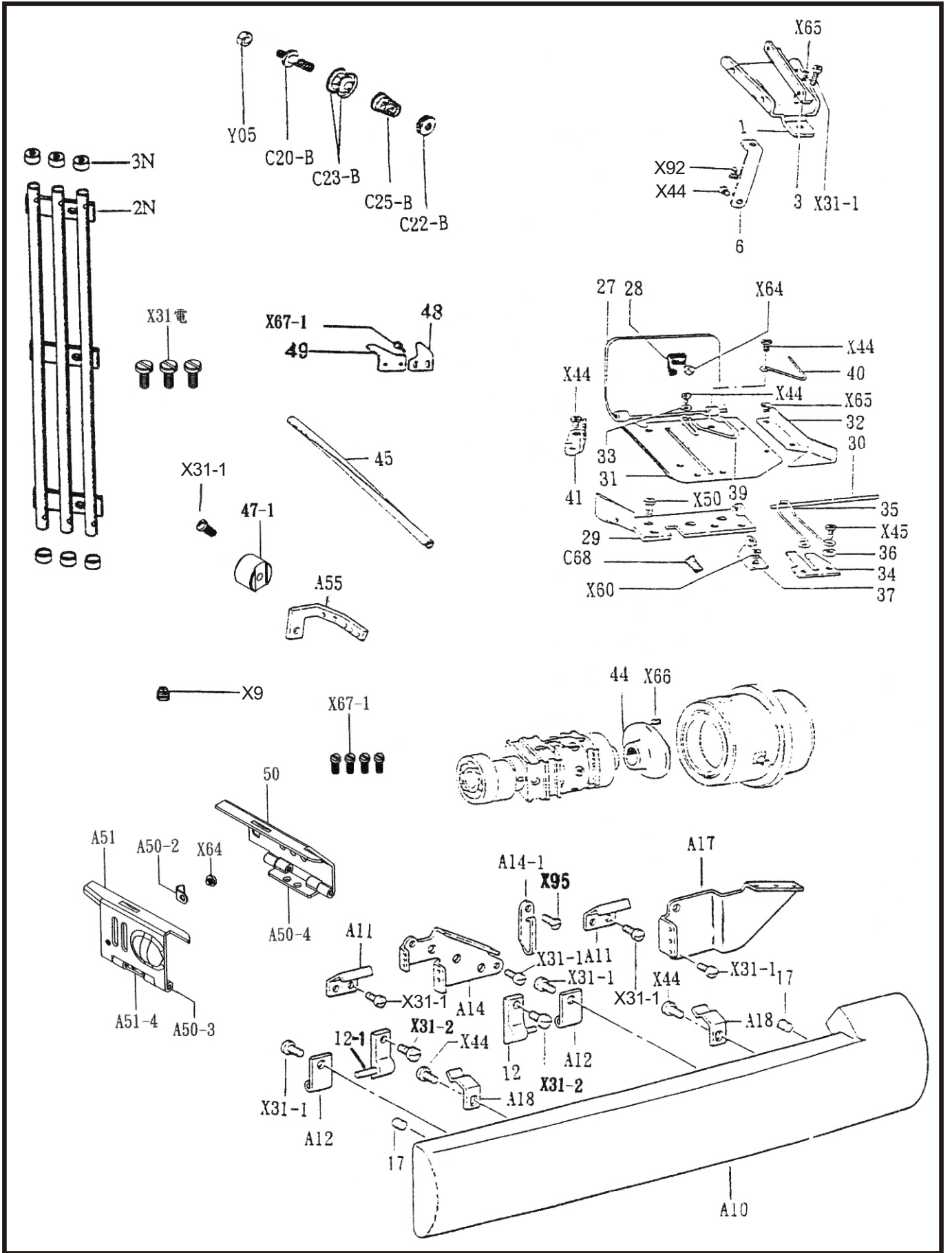

LOWER THREADING MECHANISM

REF. NO. 部件編號	NAME OF PARTS 說明	Amt req 需求量
C7-01	LOERT THREAD GUIDE RETAINER 導線架(上)	1
C7-02N	THREE PIPE-LINE THREAD TUBE 三線過線管	1
C7-03	BRACKET 過線片	1
C7-03N	THREAD TUBE CLAMP 導線圈	6
C7-06	LOWER THREAD GUIDE SUPPORTER 支架輔助	1
C7-12	LOWER THREAD GUIDE HINGE ASSEMBLY 活動鈕(上)	2
C7-12-1	LOWER THREAD GUIDE HINGE ASSEMBLY 活動鈕插銷	2
C7-17	LOWER THREAD COVER 橡膠墊	2
C7-A10	LOWER THREAD COVER 下前蓋	1
C7-A11	PLATE SPRING 彈簧勾	2
E7-A12	FIXING PLATE 活動鈕(下)	2
C7-A14	LOWER THREAD TENSION BRACKET 三通過線片	1
C7-A14-1	THREAD GUIDE 穩線片	1
C7-A17	LOWER THREAD GUIDE RETAINER ?通過線片	1
C7-A18	PLATE SPRING 彈片勾	2
C7-A50	LOOPER SIDE COVER (R) ASSY 彎針護蓋	1
C7-A51	LOOPER SIDE COVER (L) ASSY 彎針護蓋	1
C7-A55	LOWER THREAD GUIDE 過線片	1
C7-C20-B	THREAD TENSION ROD 沙拉螺柱	3
C7-C21-B	LOWER TEREAD TENSION BRACKET 沙拉托架	3
C7-C22-B	LOWER TEREAD TENSION NUT 沙拉螺母	3
C7-C23-B	LOWER TEREAD TENSION PLATE 沙拉片	6
C7-C25-B	LOWER TEREAD TENSION SPRING 沙拉彈簧	3
C7-27	THREAD TAKE-UP LEVER COVER 護線蓋	1
C7-28	SPRING 彈簧勾	1
C7-29	LOWER THREAD TAKE-UP LEVER FRAME 過線輔助架	1
C7-30	LOWER THREAD TAKE-UP LEVER COVER SHAFT 銷	1
C7-31	LOWER THREAD TAKE-UP LEVER BASE 過線支架	1
C7-32	GUIDE PLATE 過線輔助架	1
C7-33	WASHER 墊圈	1
C7-34	LOERT THREAD GUIDE PLATE 固定片	1
C7-35	SCREW 彈簧	1
C7-36	WASHER 墊圈	1
C7-37	LOWER THREAD GUIDE(LEFT) 彈片扣	1
C7-39	LOWER THREAD GUIDE(LEFTRIGHT) 導線勾	2
C7-40	LOWER THREAD GUIDE(LEFT) 導線勾	1
C7-41	LOWER THREAD GUIDE PLATE 固定片	1
C7-44	LOWER THREAD TAKE-UP DISC ASSEMBLY 配線凸輪	1
C7-45	LOWER THREAD FEED TUBE 過線管	1
C7-47-1	LOOPER THREAD GUIDE BRACKET 針受座	1
C7-48	THREAD CUTTER GUIDE PLATE 切線刀	1
C7-49	THREAD CUTTER 切線刀	1
C7-A50-2	STOPPER SPRING PLATE 彈片勾	2
C7-A50-3	PIN 銷	4
C7-A50-4	FACE PLATE UPPER HINGE ASSEMBLY(R) 蝴蝶後扭(右)	1
C7-A51-4	FACE PLATE UPPER HINGE ASSEMBLY(L) 蝴蝶後扭(左)	1
C7-C68	PIN 銷	1
C7-X9	SCREW 15/64x28 螺釘	1
C7-X31	SCREW 11/64x40 螺釘	3
C7-X31-1	SCREW 11/64x40 螺釘	12
C7-X31-2	SCREW 9/64x40 L10 螺釘	2
C7-X44	SCREW 9/64x40 L5 螺釘	7
C7-X45	SCREW 9/64 螺釘	2
C7-X50	SCREW 9/64 螺釘	2
C7-X60	SCREW 9/64x40 L4 螺釘	1
C7-X64	SCREW 3/32x56 螺釘	3
C7-X65	SCREW 3/32x56 L4 螺釘	2
C7-X66	SCREW 1/4x40 螺釘	2
C7-X67-1	SCREW 3/32x56 螺釘	6
C7-X92	SCREW 9/64x40 螺釘	1
C7-X95	SCREW 9/64x40 螺釘	1
C7-Y05	NUT 9/64x40 螺母	2

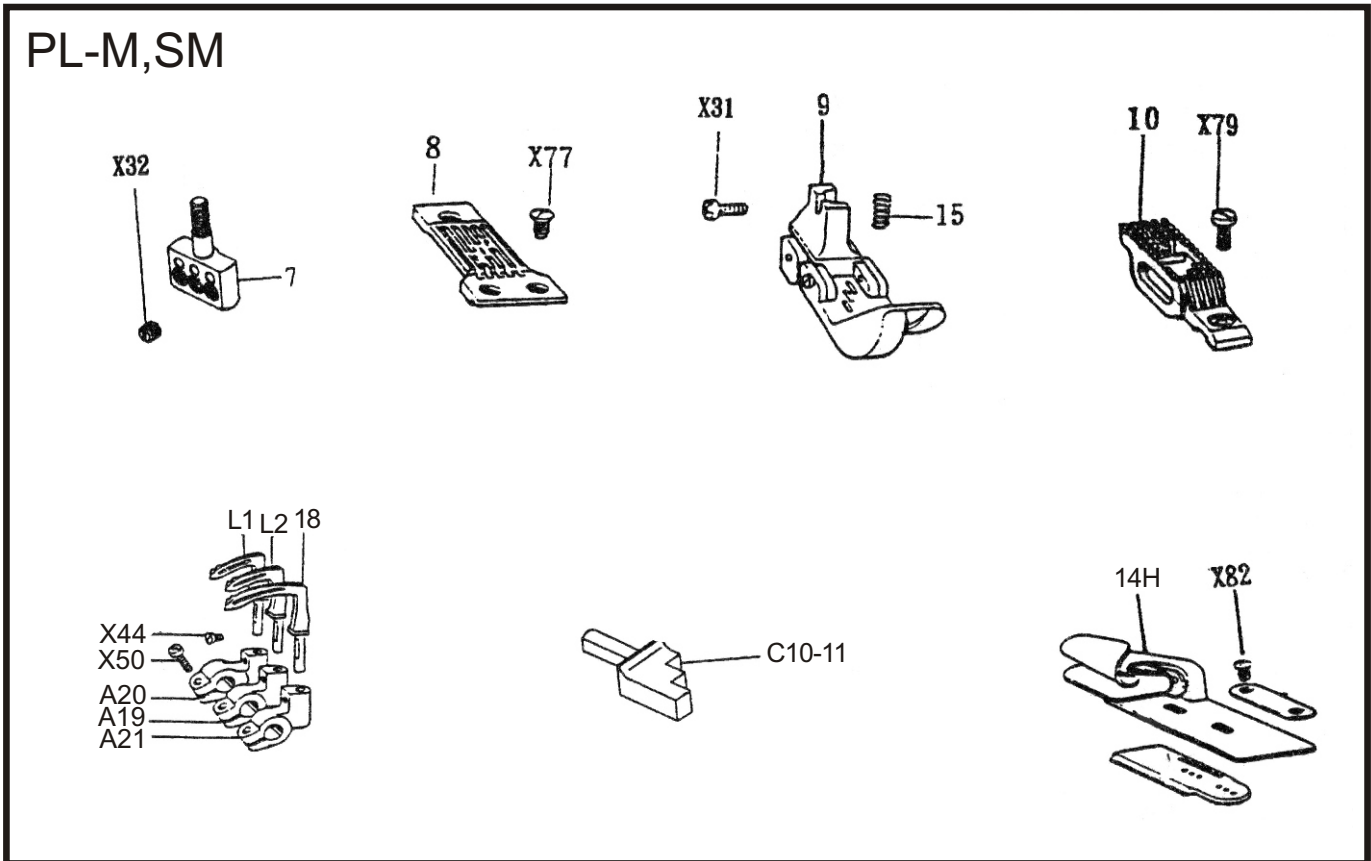
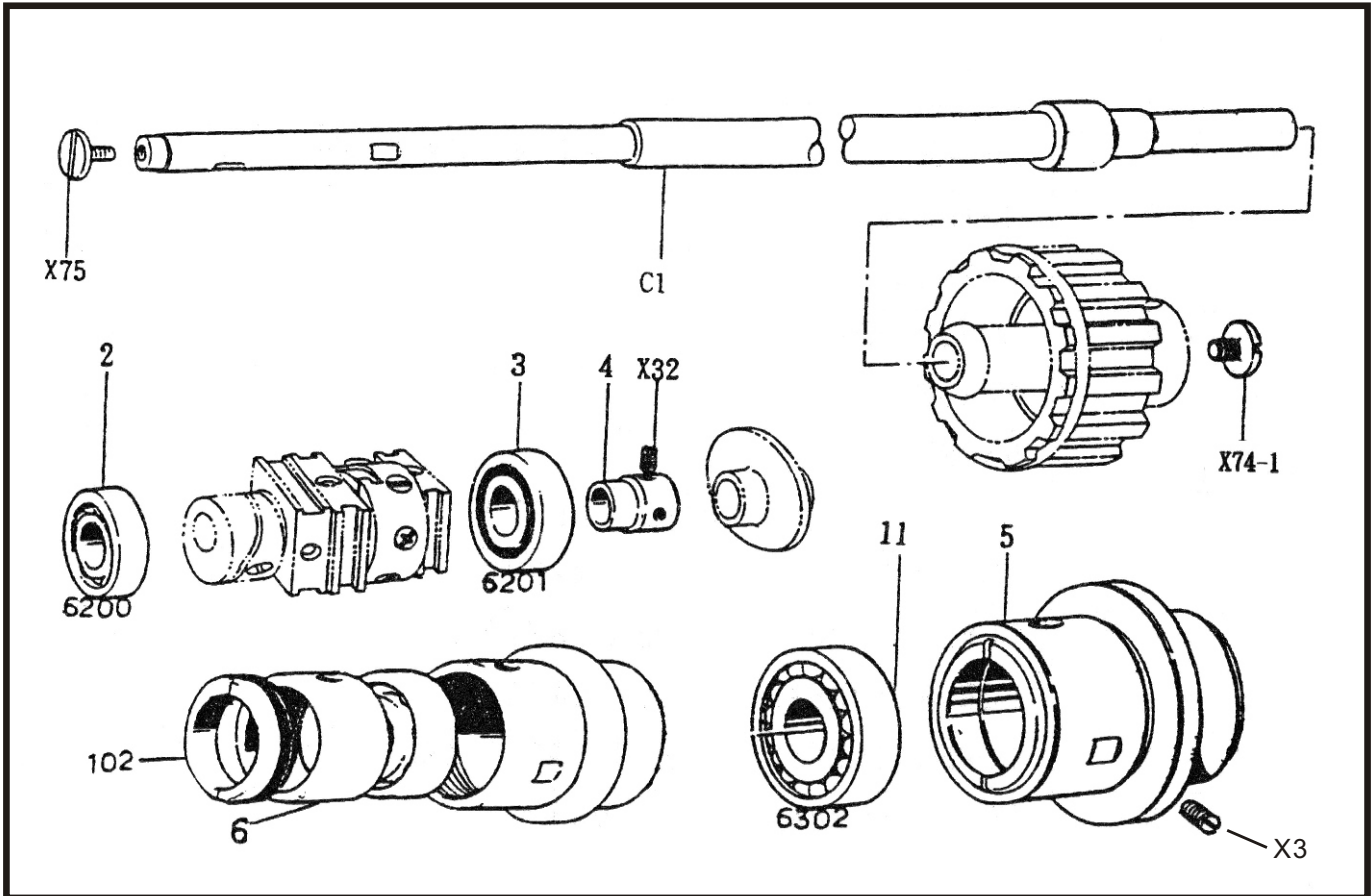

SP

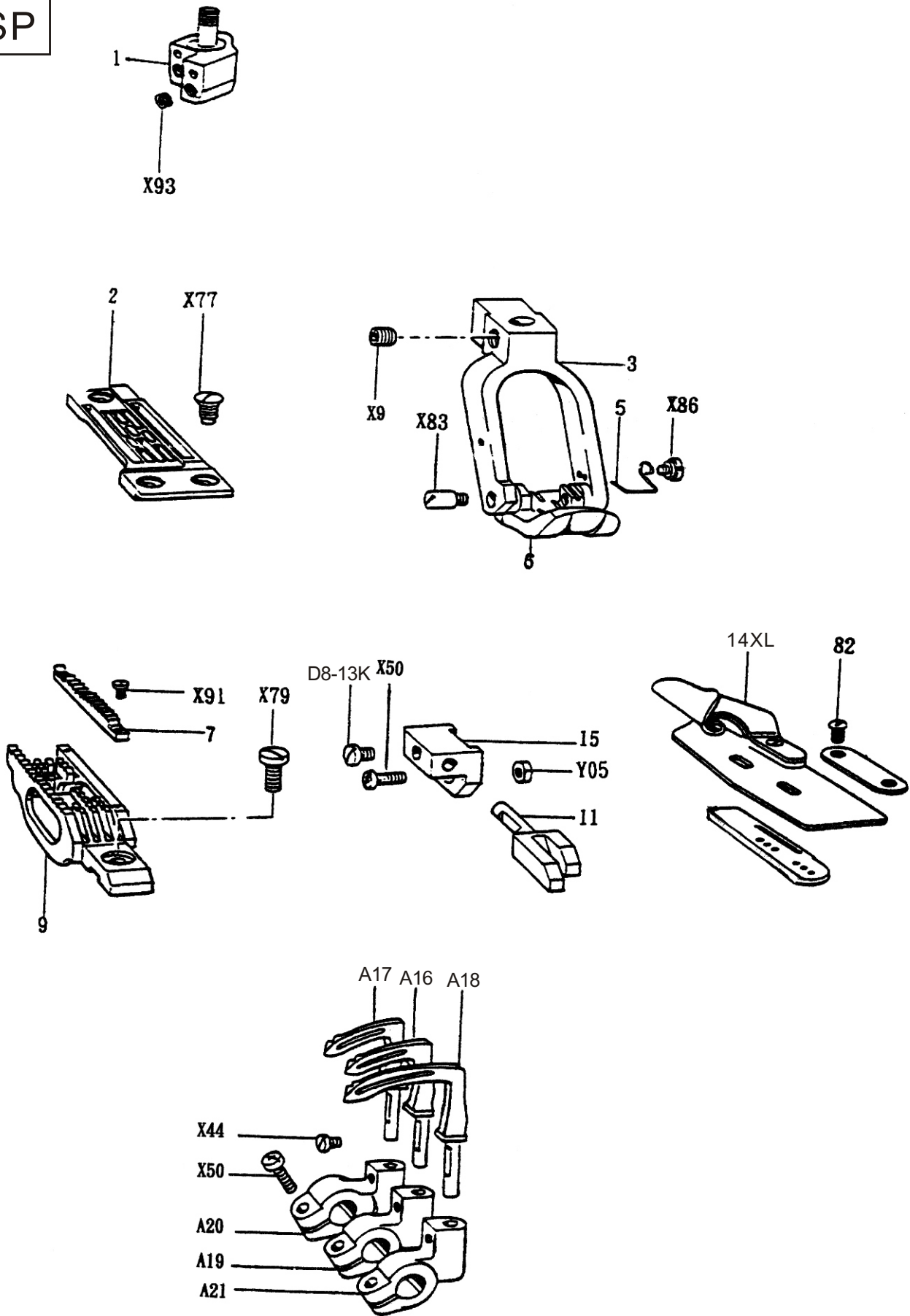

PL

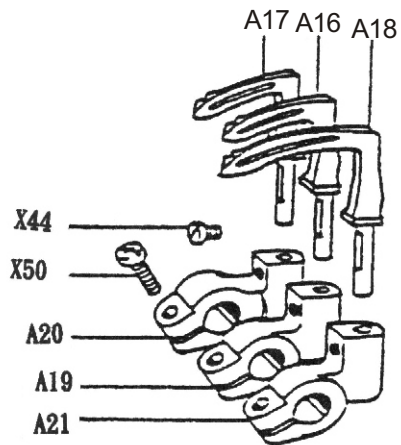
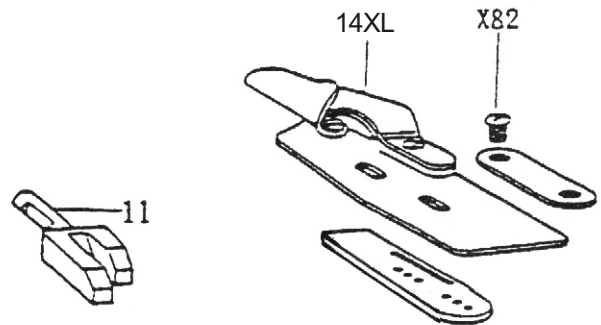
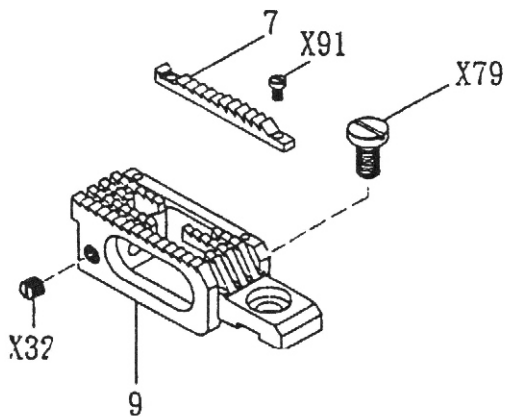
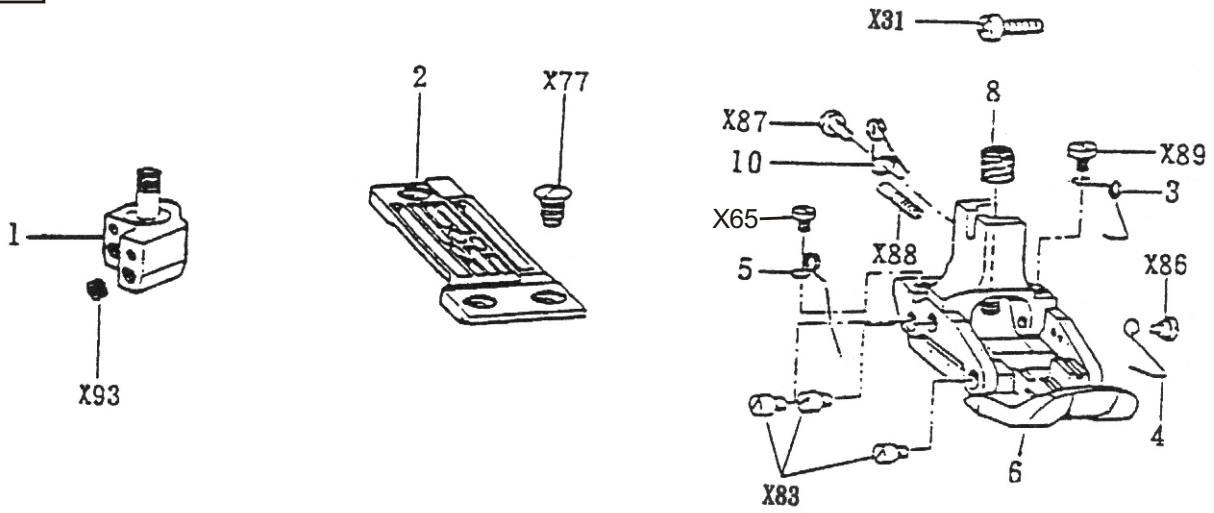

PL, PL-M

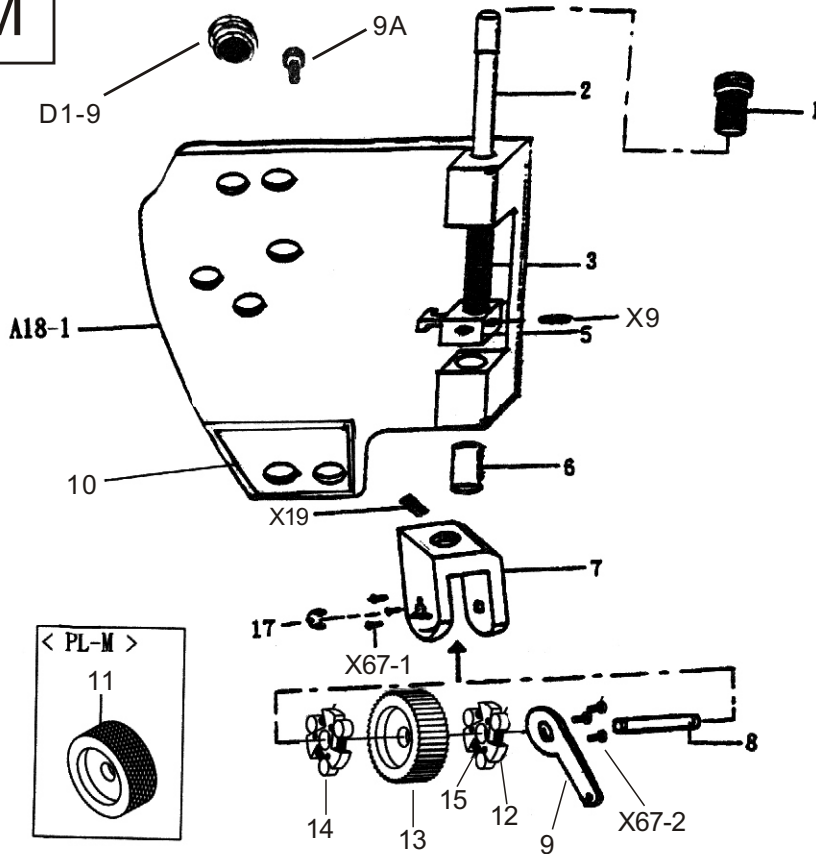

SP

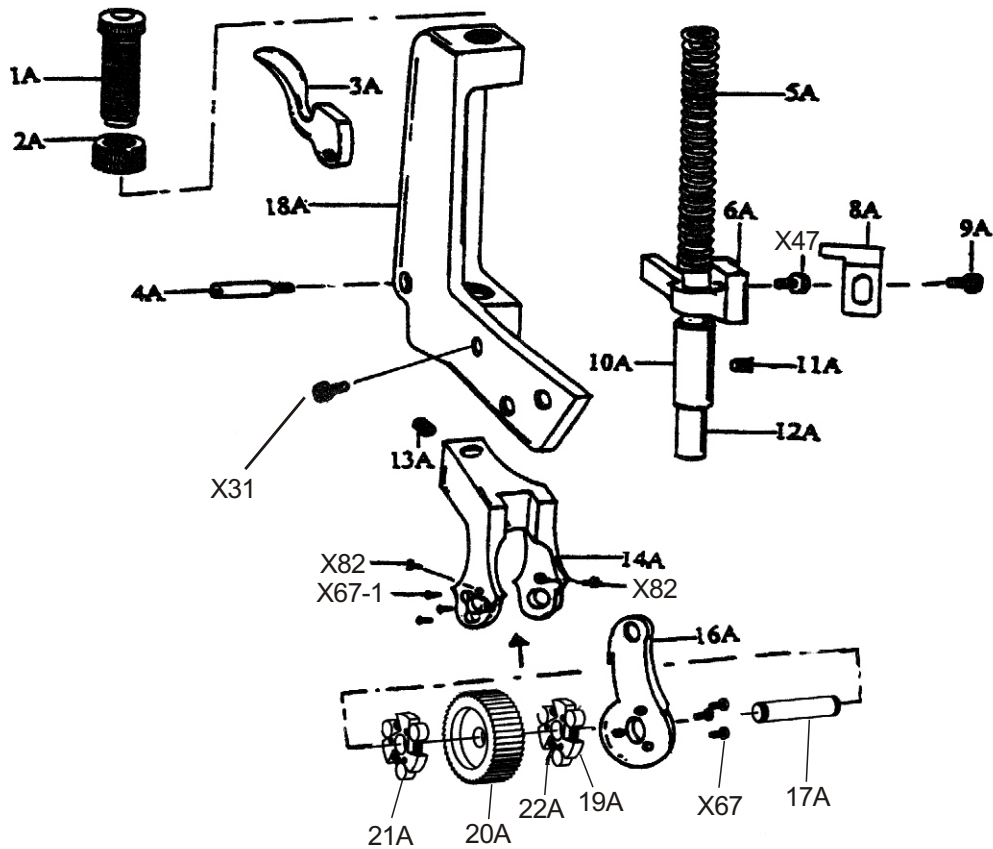

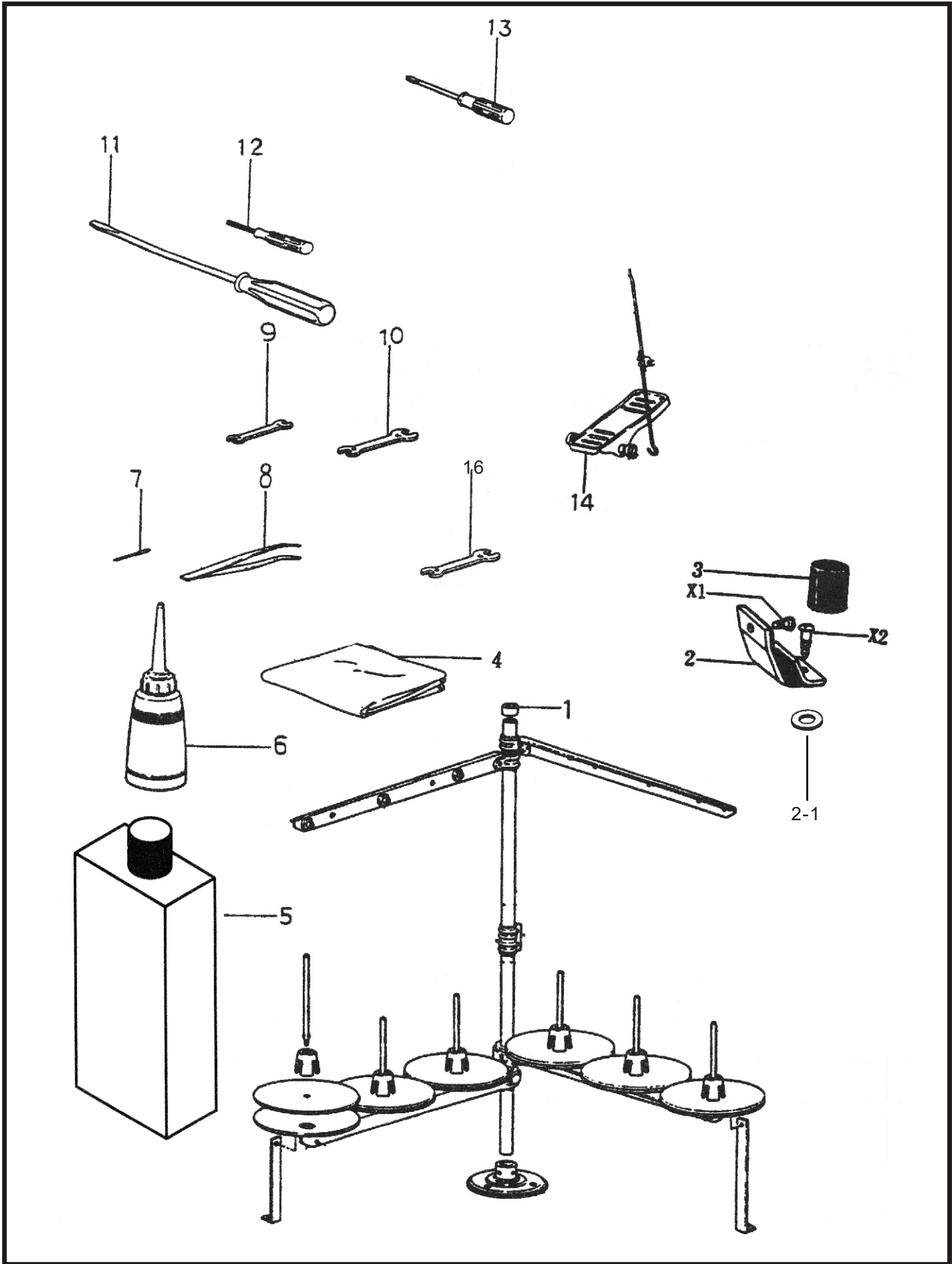

SIRUBA TABLE CUT - OUT	Series	Item Code	Subclass / Remark	Mounting
	FA007	FA007-T1	• FOR FA007 Series	Fully-submerged
				Date
				2014 / 7 / 18

單位/UNIT:mm
 所有尺寸公差/Tolerance:±2
 所有孔均倒C0.5
 全封邊灰格紋光塑面板

