



AA-6

SIRUBA[®]
銀箭牌工業用縫紉機
INDUSTRIAL SEWING MACHINE

AA-6

高林股份有限公司 KAULIN MFG. CO., LTD.

使用說明書 INSTRUCTION BOOK



EC DECLARATION OF CONFORMITY

According to the following EC Directive

Machinery Directive : 98 / 37 / EC , as amended by 89/336/ EEC and 73/23/ EEC.

The undersigned, DAVID LIN , representing KAULIN MFG. CO., LTD. 11F 128 Sec. 3 Min Shen E. Road, Taipei , Taiwan ROC., manufacturer, declares that the machine described hereafter :

Portable Bag Closer

Model :AA-2/AA-6

Provided that it is used and maintained in accordance with the generally accepted codes of good practice and the recommendations of the instructions manual, meets the essential safety and health requirements of the Machinery Directive.

For the most specific risks of the machine, safety and compliance with the essential requirements of the Directive has been based on elements of : the European Standard EN 292 - 1 & - 2 : 1992 Safety of machinery ; basic concepts, general principles for design.

The compliance of the model with the requirements of EC Machinery Directive was established by AIB-VINCOTTE Inter n.f.p, Avenue A. Drouart 27-29 , B 1160 , Brussels, Belgium (Notified body under the number 26 for machinery listed in annex IV of EC Machinery Directive).

Date : JUL. / 15 / 2005

Signature : David Lin

Qualification : VICE CHAIRMAN

General Safety Instructions

Warning ! When using this machine, basic safety precautions should always be followed to reduce the risk of fire, electric shock and personal injury, including the following.

Read all these instructions before operating this product and save these instructions.

1.Keep work area clean.

Cluttered areas and benches invite injuries.

2.Consider work area environment.

Do not expose power to rain. Do not use machine tools in damp or wet locations. Keep work area well lit.

Do not use power tools where there is risk to cause fire or explosion.

3.Guard against electric shock.

Avoid body contact with earthed or grounded surfaces (e.g. pipes, radiators, ranges refrigerators).

4.Keep children away.

Do not let visitors touch the tool or extension code.

5.Dress properly.

Do not wear loose clothing or jewelry, they can be caught in moving parts. Wear protecting hair covering to contain long hair.

6.Do not abuse the cord.

Never carry the machine by cord or yank it to disconnect it from the socket. Keep the cord away from heat, oil and sharp edges.

7.Maintain machine with care.

Follow instructions for lubrication and changing accessories. Inspect tool cord periodically and if damaged have it repaired by an authorized serviced facility.

8.Disconnect machine

When not in use, before servicing and when changing accessories.

9.Avoid unintentional starting.

Do not carry a plugged in tool with a finger on the switch. Ensure switch is off when plugging in .

10.Check damaged parts.

Before further use of the tool, a guard or other part that is damaged should be carefully checked to determine that it will operate properly and perform its intended function.

11. Warning.

The use of any accessory or attachment, other than those recommended in this instruction manual, may present a risk of personal injury.

12. Have your tool repaired by a qualified person.

Repairs should only be carried out by qualified persons using original spare parts.

Special Warning For Electric Connection !

- 1.Incorporate this machine only with "CE" certificate hold to run control device.
- 2.Follow the instruction manual device to install control device.
- 3.Always earth machine appropriately during operation.
- 4.Before adjustment, parts change or servicing must be sure to pull out the plug from socket to prevent the hazard of unintentionally start of machine.

索引	INDEX	頁/PAGE
規格說明	SPECIFICATIONS	1
主要的特徵	FEATURES	1
維修	MAINTENANCE	1
馬達須知	NOTIC	2
穿線	THREADING	2
針之安裝	INSTALLATION OF NEEDLE	3
針棒之調整	ADJUSTMENT OF NEEDLE BAR	3
針距	STITCH LENGTH	4
勾針之安裝	INSTALLING AND/ OR REPLACING THE LOOPER	4
勾針之調整	ADJUSTING THE LOOPER	5
故障排除	TROUBLE SHOOTING	5
· 斷線	· THREAD-BREAKING	
· 跳針	· STITCH-SKIPPING	
· 斷針	· NEEDLE-BREAKING	
· 不會打結	· FAILURE IN SEWING	
· 針距不一	· STITCHING BEING UNEVEN	

MODEL		AA-3/AA-6	
Net Weight (Kgs)	5	Noise Level, dB(A)	75.5dB(A)
Serial No.		Vibration(m/sec ²)	
Dimension	Length 32cm	Width 22cm	Height 30cm

規格說明

針 : D5
馬達 : 1/8HP, 90W.
針距 : 7.2mm
重量 : 5kgs

SPECIFICATIONS

Needle : D5
Motor : 1/8HP, 90W.
Stitch length : 7.2 mm
Weight : approx.5 kgs

主要的特徵

- 1.單線環縫。
- 2.操作簡易
操作者以一手提著縫袋機，另一手拿著將被縫合的袋口，輕按控制鈕,即可開始縫,縫完後自動切斷線頭。
- 3.所有零組件都是經過嚴密設計，品質穩定，免於故障維修之苦。
- 4.可用於多層厚紙袋，PP/EE編織袋,棉,麻袋等。
- 5.可用於固定或懸吊式而無損於其手提縫紉之特性。

FEATURES

1. Single-thread chain stitching
2. Easy operation :
when the operator holds with one hand the opening of the bag to be sewn and carries the bag closer with another hand, then presses the power button and starts sewing.
When the sewing is finished , the thread will be automatically cut off .
3. Since all component parts have been carefully designed and produced, quality is very stable and reliable .
Due to this reason, the user(s) can be kept away from the trouble of repairs .
4. It can be applied to sew multi-layer PP/PE bags, and/or cotton, linen bags.
5. It can be mounted to a certain fixture for operating , or be hung together with a suspending spring from the ceiling for saving labor.

維修

除皮帶(A909)與馬達外(A900)需經常清潔及加油潤滑以維護機器的高品質車縫，但車縫澱粉類不宜加太多油。

MAINTENANCE

Check the motor belt (A909) and motor (A900) periodically.
Keep the machine clean after using and remember to oil the machine, so that it can provide you with a quality sewing. If the bag is carrying corn powder, or similar stuff, the lubricating oil can not be added too much to the machine .

馬達須知

不可將馬達控制鈕長時間按住不放，沒有車縫時，應立刻放開馬達控制鈕。

NOTICE

The operator is requested to stop pressing the power button(A806) when the sewing on one bag is finished. Otherwise the life of motor will decrease and / or possibly burn out.

穿線

為確保線已正確穿入於線架，請按圖1所示穿線。

THREADING

For a correct threading, see FIG. 1 and do accordingly .

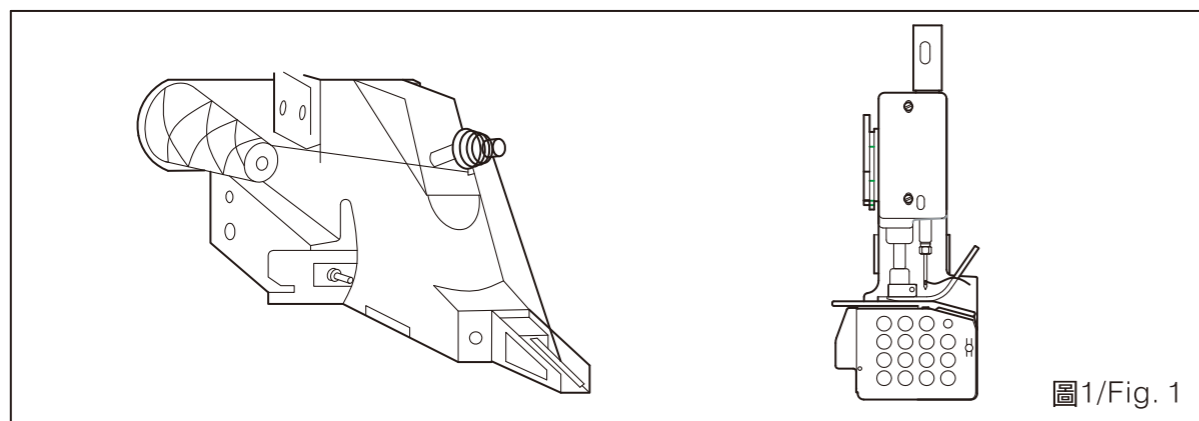

針之安裝

拉動皮帶(A909)，讓針棒(A500)最高點至最上端，鬆開螺母(A501)，拿下舊針，再將新的針插入針棒孔頂點，鎖緊螺母(A501)，切記針之長溝要朝機器左邊，如圖2、3。

INSTALLATION OF NEEDLE

Pull the motor belt (A909), to make sure the needle bar (A500) lifts to its highest position. Loosen the screw (A501) of the needle holder, take off the old needle from the needle holder, and then insert the new needle to the hole of the needle holder. Fasten the screw. During installing, remember to keep the needle's long groove facing the left side of the machine. Please see Fig. 2&3.

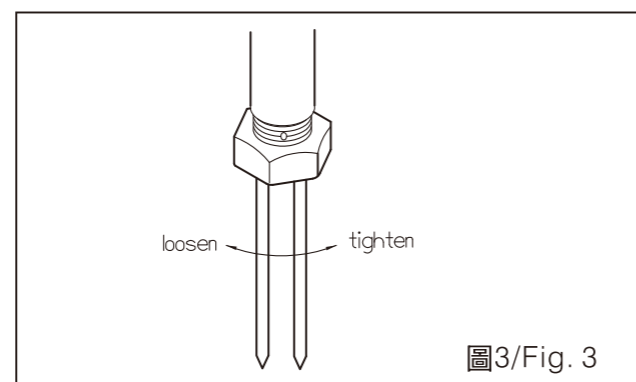
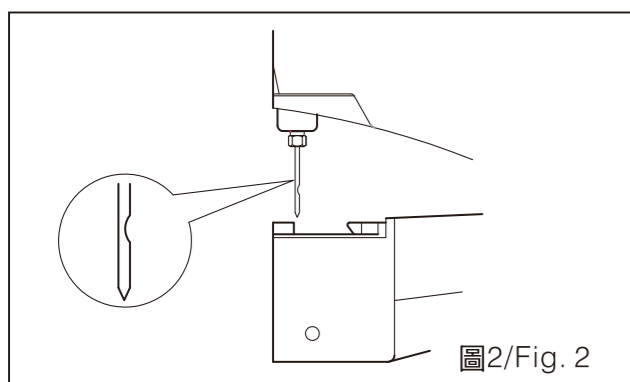

針棒之調整

- 1.卸去針棒護板A101R，轉動皮帶(A909)，使勾針移至如圖4所示。
- 2.稍微鬆開針棒之螺絲(SA26)。
- 3.調整針的高度，如圖5所示，針與勾針(A300)會合時，勾針之尖端不超過針邊緣0.4mm，而且此時勾針之尖端下緣剛好跨過針之線孔上緣。鎖緊針棒支件之螺絲(SA26)，再裝上針棒護板(A101R)，重新校對針與勾針(A300)兩者之間隙如圖6。

ADJUSTMENT OF NEEDLE BAR

- 1.Release the needle bar cover (A101R), pull the motor belt (A909) to let the looper move as per the instruction of Fig. 4.
- 2.Slightly loosen the needle bar screw (SA26).
- 3.Adjusting the height of needle, please see Fig. 5. When the needle and looper (A300) meet together, the distance between the tip of looper and the needle can not exceed over 0.4mm. At the same time, the bottom edge of the looper's tip just passes over the needle hole. Fasten the needle bar screw (SA26), put the needle bar protective cover (A101R) back, and then readjust the clearance between the needle and looper according to Fig. 6.

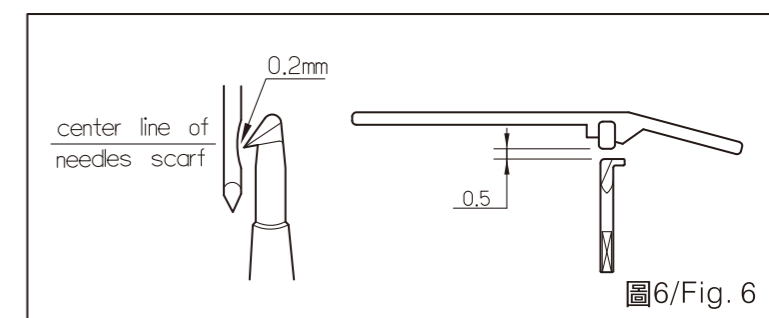
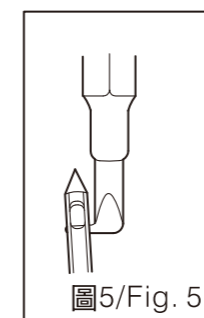
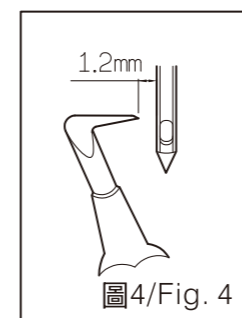

針距

正常之針距為7.2mm，而送料具(A203)高度約為2.7mm，假如針距不過長，則檢查如下：

- 1.送料具齒尖可能磨損，必須換新。
- 2.送料具可能陷下，以致送料具凸出針板之高度不及2.7mm，則調整送料具座之螺絲(SA22)即可。

STITCH LENGTH

The normal stitch length is 7.2mm, and the tips of the feed dog (A203) should be set higher than the needle plate(A210) by 2.7mm. If the stitch length is too long, check and do as follows :

- 1.The tips of feed dog may be worn out, then feed dog must be replaced.
- 2.The feed dog may possibly sink, and the height of the tips of feed dog over the needle plate is less than 2.7mm consequently. Loosen the feed dog holder screw (SA22) and adjust the feed dog.

勾針之安裝

- 1.轉動皮帶(A909)使送料具在最高點。
- 2.鬆掉勾針座螺絲(SA19)，取下勾針座(A301R)。
- 3.鬆掉勾針螺絲(SA03)，取下勾針(A300)。
- 4.換新勾針，插入勾針座內。
- 5.把勾針座裝入勾針座軸上(A303R)，調整勾針座如圖6，並鎖緊螺絲(SA03)。
- 6.調整勾針座(A301R)如圖4，並鎖緊螺絲(SA19)。

勾針之調整

- 1.若只是更換勾針是不須要調整，但在換過“勾針軸”(A303R)，塑膠凸輪(A301R)或凸輪組件就必須作調整。
- 2.勾針在回程之極點，勾針針端和針邊緣距離約1.2mm，如圖4。
- 3.若必須調整時，首先轉動皮帶(A909)，使勾針移至回程之極點，然後鬆開從件搖臂之螺絲(SA03)即調整之。

INSTALLING AND/ OR REPLACING THE LOOPER

- 1.Turn the motor belt (A909) to make sure the feed dog is at its highest position.
- 2.Loosen the looper holder screw (SA19) and take off the looper holder (A301R).
- 3.Loosen the screw (SA03) of looper, and take off the looper(A300).
- 4.Replace the old looper, and put the new looper to the holder.
- 5.Put the holder back to the holder bed (A303R) and adjust the height and timing of looper as per Fig. 6 and fasten the screw (SA03).
- 6.Adjust the position of looper holder (A301R) as per Fig. 4 and fasten the screw (SA19).

ADJUSTING THE LOOPER

- 1.If the replacement of looper is required, the adjustment is then not necessary. But when the looper holder bar, plastic cam or cam component parts are replaced, the adjustment would be a must.
- 2.When the looper returns backwards to its extreme, looper's tips will be only away from the needle's edge about a distance 1.2mm see Fig. 4.
- 3.If a adjustment is required, first move the motor belt A909, to let the looper come back to its extreme position. Loosen the screw (SA03) on looper holder bed, and then adjust it.

故障排除

斷線

- 1.縫合壠青紙袋或防水紙袋，請先將線上油，以增潤滑防斷線。
- 2.若勾針損壞或調不正確，勾針針頭必須磨光或換新再重新調整。
- 3.不正確穿線或張力，如圖檢查穿線。

跳針

- 1.縫合壠青紙袋或防水紙袋，請先將線上油以增潤滑。
- 2.勾針位置配合不正確，檢查勾針位置如圖5、6。
- 3.針的位置放置不正確，檢查針位置如圖2。
- 4.過線彈簧可能受損，必須換新。

斷針

- 1.針安裝不正確，檢查針的長溝是否在機器的左邊，如圖。
- 2.勾針安裝是否不正確，如圖4調整。

不會打結

- 1.針板彎曲不平，弄平或換新。
- 2.押具可能磨損不平，換新。

針距不一

- 1.押具壓力不當，調整適當之壓力。
- 2.送料具磨損，換新。

TROUBLE SHOOTING

THREAD-BREAKING

- 1.Before sewing the pitch-coated bags or water-proof paper bags oil the thread first to increase the lubrication, so that thread breaking can be avoided.
- 2.If the looper is damaged or incorrectly adjusted, looper's tip needs to be polished or replaced, and then adjust once again.
- 3.The thread breaking may be caused by incorrect threading or wrong thread tension. Check the threading as per Fig. 1.

STITCH-SKIPPING

- 1.When sewing the pitch-coated bags or water-proof paper bags, the stitch-skipping easily happens. We suggest oiling the thread before sewing.
- 2.The position of looper may be wrong. Check the looper as per Fig. 5&6.
- 3.The position of needle is wrong, Check the needle as per Fig. 2.
- 4.Threading tension spring may be damaged. Replace the damaged one.

NEEDLE-BREAKING

- 1.Incorrect needle installation. Check if the needle's long groove is facing the left side of the machine.
- 2.Incorrect needle installation. Check and adjust as per Fig. 4.

FAILURE IN SEWING

- 1.The needle plate may be deformed. Replace it.
- 2.The presser foot may be damaged. Replace it.

STITCHING BEING UNEVEN

- 1.The pressure of the presser foot may be improper. Adjust the pressure.
- 2.The feed dog is damaged. Replace it.