

SIRUBA

使用說明書與零件圖

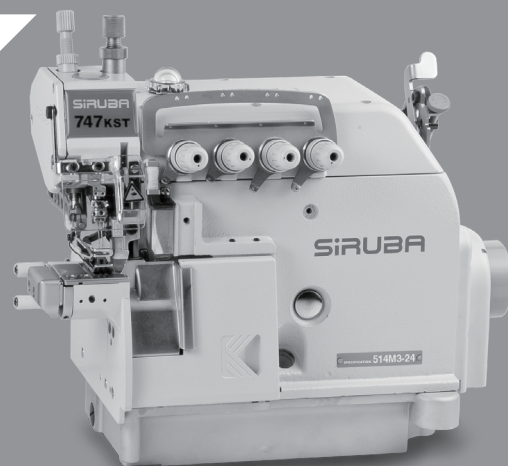

INSTRUCTION BOOK & PARTS LIST

■ 700KST







CE

危險水準的說明 Explanation of Dangerous Level

 危險 Dangerous	<p>如果忽視此標記而運行了錯誤的機械操作, 保養時肯定會引起當事者或第三者人員重傷或死亡</p> <p>Don't ignore the warning sign and don't proceed incorrect operation. Or it will cause the person or the third party seriously injured or dead during maintenance.</p>
 注意 Caution	<p>如果忽視此標記而運行了錯誤的機械操作, 保養時有可能會引起當事者或第三者人員受傷及造成設備損壞</p> <p>Ignoring this warning sign and proceed incorrect operation will cause the person involved or the third party wounded and equipment damaged during maintenance.</p>

警告圖案表示及表示標幟的說明 Explanation of Warning Signs and Labels

警告圖案表示 Warning Sign		運動部位, 謹防工傷事故 Moving part, beware of industrial accident
		高壓部位, 謹防觸電事故 High voltage, beware of electric shock
		高溫部位, 謹防燙傷事故 High temperature, beware of burns
指示標誌 Instruction Label		禁止 Prohibited
		地線的接線表示 Indication of ground wiring

索引	INDEX	頁 /PAGE
致使用者	TO THE OPERATORS	1
警告標籤	WARNING TAG	1
搬運縫紉機	MOVING THE SEWING MACHINE	2
縫紉機的安裝位置	THE INSTALLATION POSITION	2
規格	SPECIFICATIONS	3
各部件名稱	NAMES OF MAJOR PARTS	5
安裝	INSTALLATION	6
新機器啟用規定	HOW TO OPERATE THE NEW MACHINE	8
潤滑油之注入與更換	LUBRICATION AND DRAINAGE	8
穿線方法	THREADING	10
控線調整	ADJUST THREAD TENSION	11
換針方法	REPLACE THE NEEDLE	13
針距調整	ADJUST THE STITCH LENGTH	13
差動比調整	ADJUST THE DIFFERENTIAL FEED RATIO	14
更換切刀	REPLACE THE TRIMMERS	16
針高度之調整	ADJUST THE NEEDLE HEIGHT	17
押具調整	ADJUST THE PRESSER FOOT	17
送具調整	ADJUST THE FEED DOG	19
針與勾針之關係	THE RELATIONSHIP BETWEEN NEEDLE AND LOOPER	21
上送具高低行程調整	ADJUSTMENT OF THE HIGH-LOW STROKE OF THE UPPER FEED DOG	24
上送具與差動齒之關係	RELATION BETWEEN THE UPPER FEED DOG AND THE DIFFERENTIAL FEEDER	25
上送具前後行程調整	ADJUST THE FRONT-REAR STROKE OF UPPER FEEDER	25
定位勾針線挑線凸輪	POSITION THE LOOPER AND TAKE-UP THREAD CAM	27
操作環境照明	LIGHTENING OF THE OPERATION ENVIRONMENT	28

索引	INDEX	頁 /PAGE
操作者條件	CONDITIONS OF ALL OPERATORS	28
保養	MAINTENANCE	29
報廢流程	DEMOLITION PROCEDURE	30
桌板圖	TABLE CUT-OUT	31
規格件表	GAGE PARTS LIST	36
零件圖	PARTS LIST	37

致使用者

- 我們非常感謝您使用本公司出品之超高轉速直驅式直針鎖邊縫紉機 (拷克車)。
- 請詳細閱讀此說明書，將使您更了解本機器獨特之性能及正確的使用方法，進而提高您縫製的效率及品質。
- 首先請您注意：請先注入潤滑油及確認馬達之轉向為順時鐘方向，才可以啟動本機器。

TO THE OPERATORS

- Thank you very much for using our Ultra High Speed Straight Needle Overlock/ Safety Stitch Machine.
- Before operating his machine Please study this book carejully undwrstand the junction and jeatures of the machine.
- Then it will help you to crease your sewing efficiency and quality.

警告標籤

- 縫紉機上有警告標籤。
- 當使用縫紉機時，請遵守標籤上的說明。如果標籤脫落或模糊不清，請和購買商店聯繫。(圖 1)

WARNING TAG

- The following warning tags will be attached on the sewing machine.
- Please obey the instruction of the labels while using it. If the labels were fallen or blurred, please contact the stores where the machine was bought.(Fig.1)

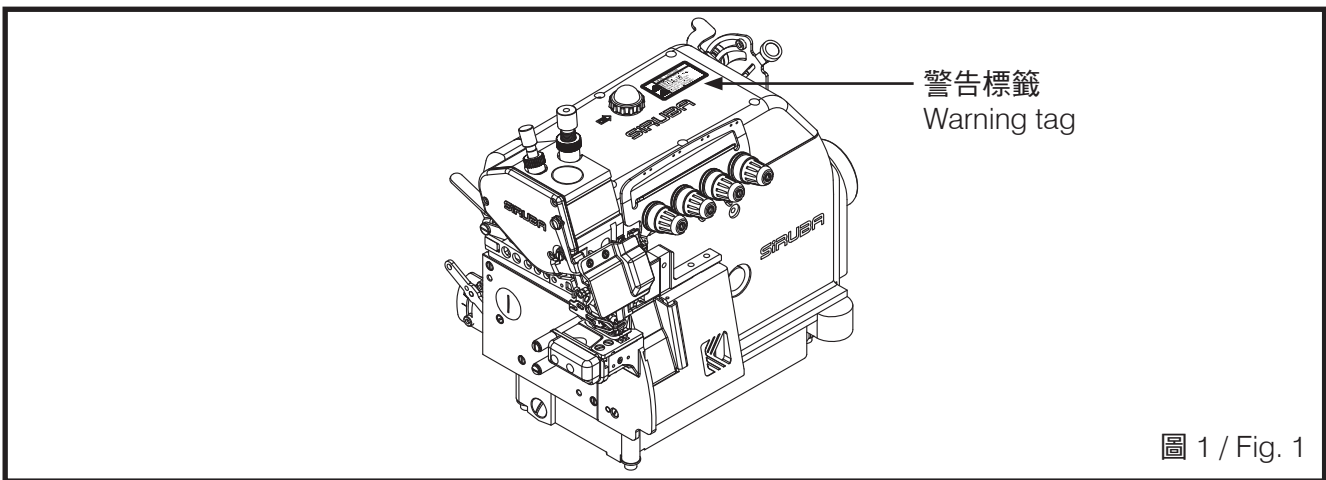

- 安全防護裝置及 ↻ 轉動方向。(圖 2)

- Safety protection device and ↻ rotary direction. (Fig.2)

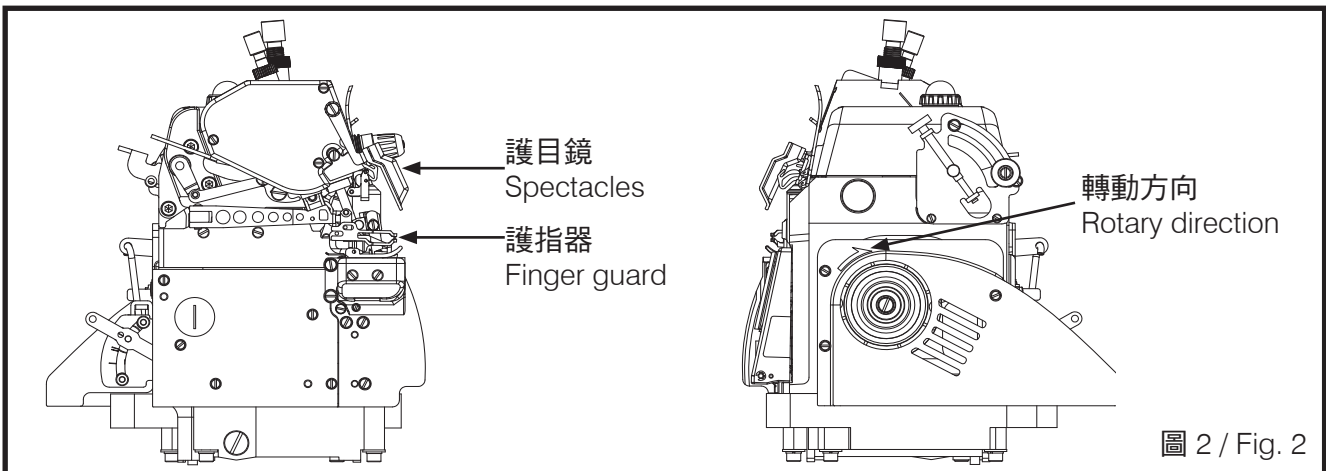

搬運縫紉機

MOVING THE SEWING MACHINE

- 應按圖適用左手托住前機殼本體，右手撐扶住底盤進行搬運。(圖 3)
- 搬運時需穿著安全鞋。

- Follow the instruction figure, hold the front cover of the machine with the left hand, and then hold the bottom machine with right hand to move it.(Fig.3)
- Should wear safety boots while moving.

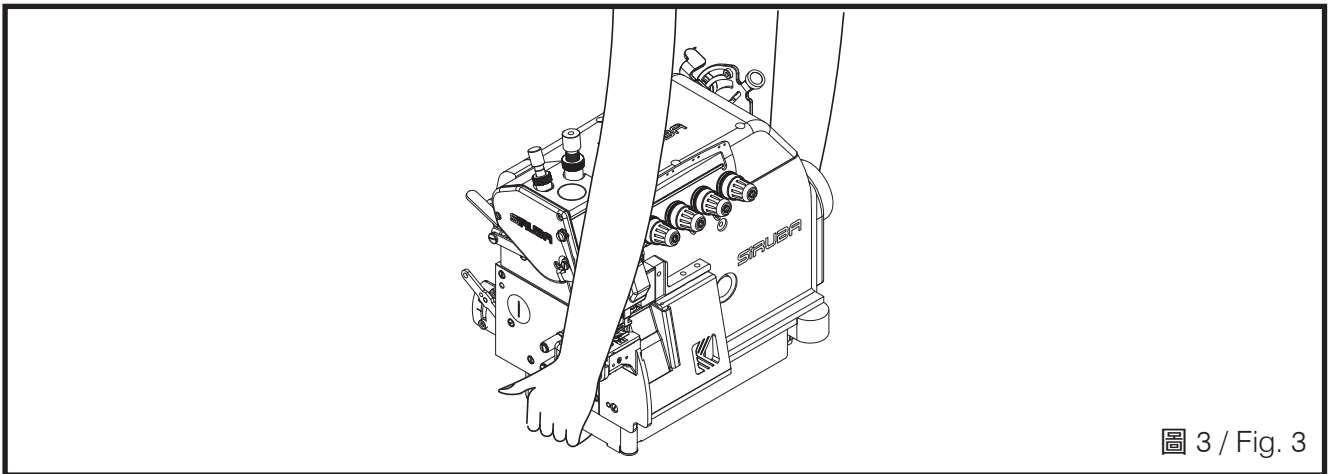

縫紉機的安裝位置

THE INSTALLATION POSITION

- 勿將該縫紉機置於設備附近，如電視機收音機或無線電話等，否則這些設備可能會對縫紉機的電子干擾所影響。
- 應將縫紉機直接插入 AC 電源插座，如果使用延長線，可能會造成操作故障。(圖 4)

- Do not put the sewing machine around the following devices, such as televisions, radios or wireless telephones etc. Otherwise, the electricity from these devices could influence the performance.
- Directly insert into AC power socket; using extended cord could cause malfunction. (Fig.4)

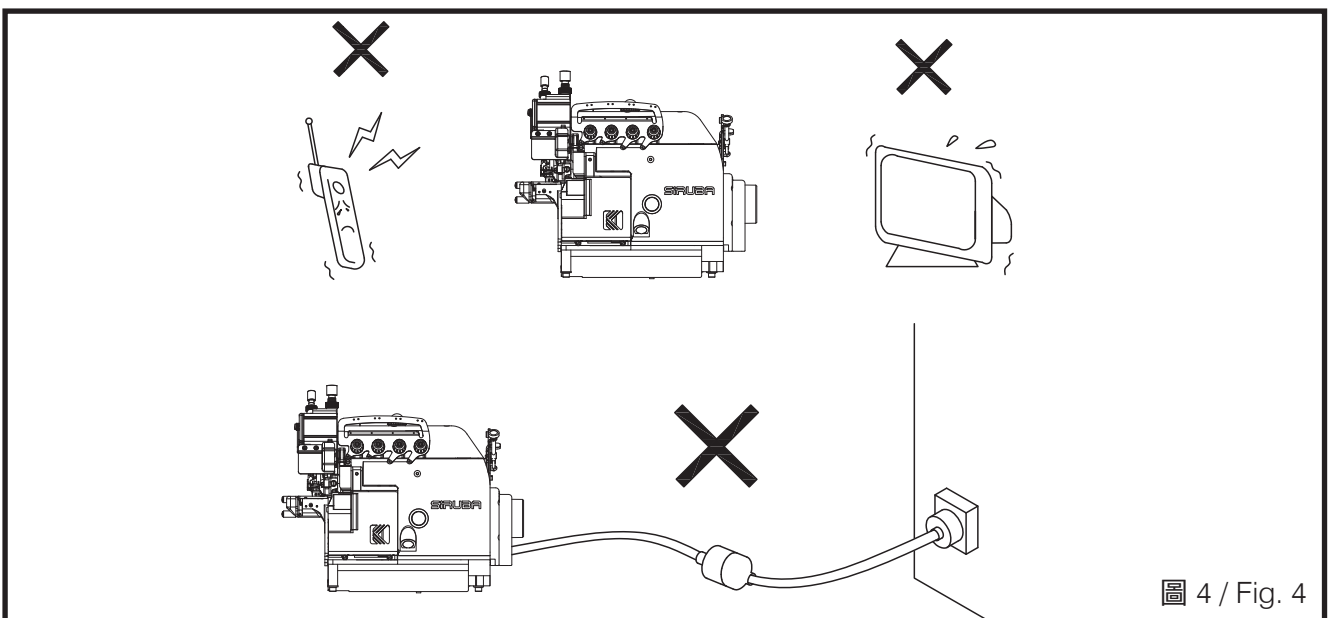

規格

SPECIFICATIONS

1. 外銷型號分類：

1.Description:

747
K
ST
-
514
M
-
3
-
2
4
VT

(1) (2) (3) (4) (5) (6) (7) (8) (9)

- (1) 線數：737 為 3 線、747 為 4 線
- (2) 表示車台機構及外觀改良之區分編碼
- (3) ST：筒車
- (4) 縫合方式 (圖表 1)

- (1) Thread Numbers: 3 for 737, 4 for 747
- (2) Distinguishing code for machine mechanism and improved appearance.
- (3) ST: Cylinder bed
- (4) Sewing types (Chart 1)

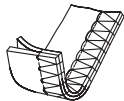
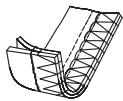
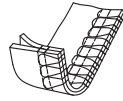
型式 Type	504	505	514
圖形 Pattern			

圖表 1 / Chart 1

- (5) 車縫布料：
 - F：輕薄布料
 - L：薄布料
 - M：中厚布料
 - H：厚布料
 - X：特厚布料
- (6) 送具型式：
 - 1：標準 1 排
 - 2：標準 2 排
 - 3：標準 3 排
- (7) 針寬：0：單針；2：2mm
- (8) 包邊寬度：
 - 3：3mm、4：4mm、5：5mm、6：6mm
- (9) 搭配外掛多功能輔助件

- (5) Sewing materials:
 - F: Fine weight material
 - L: Light weight material
 - M: Medium weight material
 - H: Heavy weight material
 - X: Extra heavyweight materia
- (6) Feed dog type:
 - 1: Standard first type
 - 2: Standard second type
 - 3: Standard third type
- (7) Needle Width: 0: single stitch; 2: 2mm
- (8) Seam Width :
 - 3: 3mm、4: 4mm、5: 5mm、6: 6mm
- (9) Multi-function Attachment

2. 規格說明 (表 1)

2. Specification (Table 1)

機型 Model	700KST
最高縫速 Max Stitch Speed	6300rpm
噪音值 Noise Level	82 分貝以下 under 82 dB (5500rpm 測試數值 test value)
縫距 Stitch Length	4 / 5 / 6 mm
針棒行程 Stroke of the needle bar	24.3 ±0.2 mm
押具揚程 Presser Foot Lift	5mm
押具壓力 Presser Foot Pressure	5kg
送具高度 (凸出針板面) Feed Dog Height (over the plate)	0.8~1.0mm
使用針 Needle for Use	DCX27
送具傳動方式 Feed Dog Transmission	偏心輪、連桿 Eccentric, Connecting Rod
縫目調整裝置 Stitch Adjusting Device	按鈕調整 Button Adjustment
押具裝置 Presser Foot Device	彈簧式、旋鈕調整式 Spring Type, Knob Adjustment Type
加油方式 Oil Filling	儲油槽儲存方式，毛氈、棉線毛細管自動供油 Oil tank storage type. Automatic oil supply by Oil felt, cotton thread capillary action.
回油方式 Oil Return Solution	偏心泵浦 Eccentric Pump
使用油 Oil for Use	提供專用油 (MOBIL #10) Provide Specific Oil (MOBIL #10)

表 1/ Table 1

各部件名稱

NAMES OF MAJOR PARTS



圖 5 / Fig. 5

- (1) 押具扳手 (圖 5)
- (2) 押具
- (3) 控制箱
- (4) 線架
- (5) 油窗
- (6) 手輪

- (1) Lifting lever (Fig. 5)
- (2) Presser foot
- (3) Control box
- (4) Thread stand
- (5) Oil gauge window
- (6) Pulley (Hand Wheel)

安裝

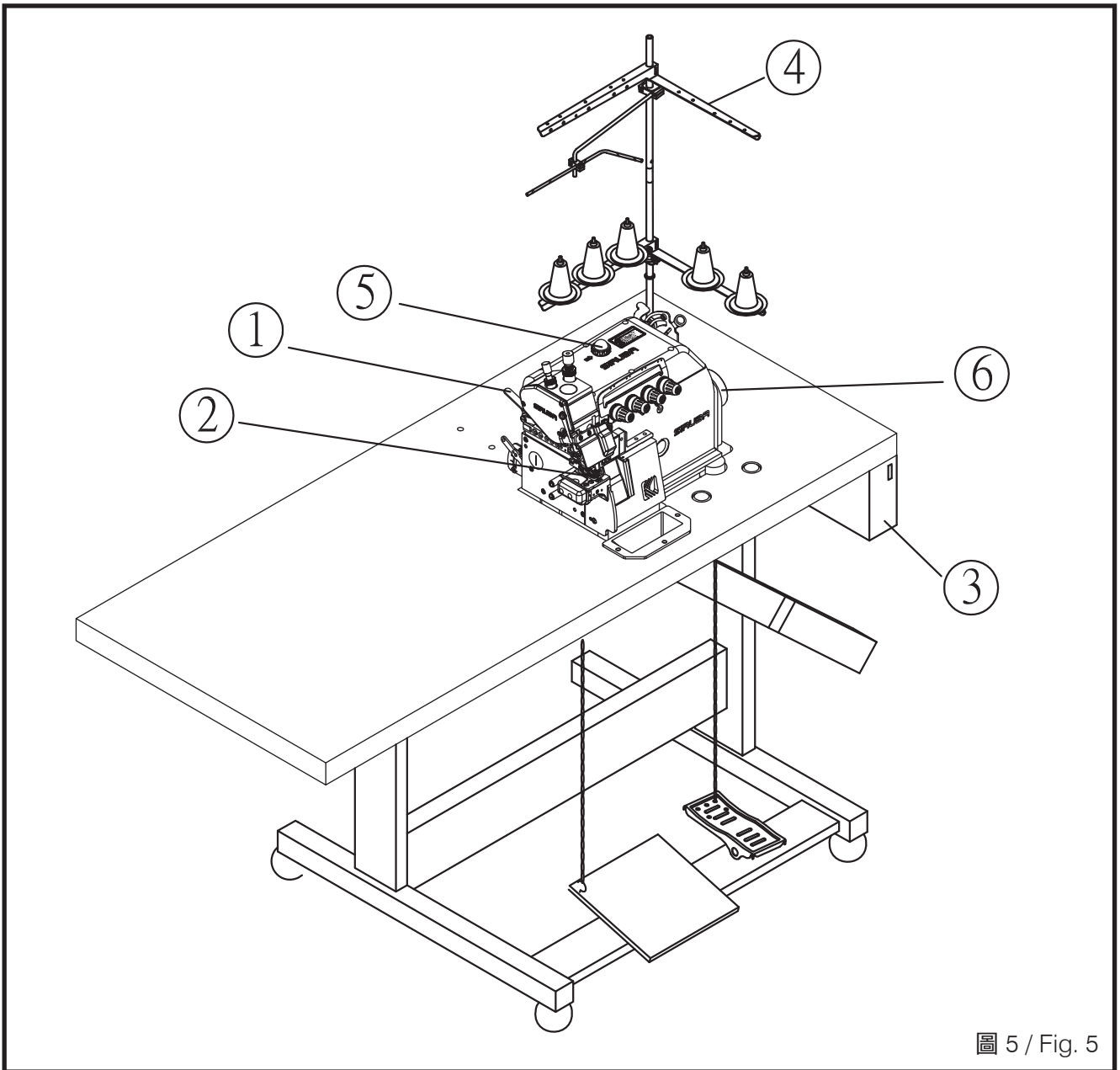
INSTALLATION

1. 縫紉機拆箱搬運過程中，不可扶持針座板①下方(圖6)。
2. 依本機所附桌板裁製圖及零件組合圖所列之配件，依序安裝防震機座鋁板②(圖6)。
3. 裝置導布屑及線架。(圖7)

1. While unpacking and moving the sewing machine, do not hold under the stitch seat plate1.(Fig.6)
2. Based on the accessories attached with the table cut-out drawing and components drawings, install the shockproof machine bed aluminum plate1.(Fig.6)
3. Install the waste fabric guide and the thread stand.(Fig.7)



圖 6 / Fig. 6



圖 7 / Fig. 7

4. 馬達啟動踏板①裝於左邊，押具腳踏板②則裝於右邊。(圖 8)

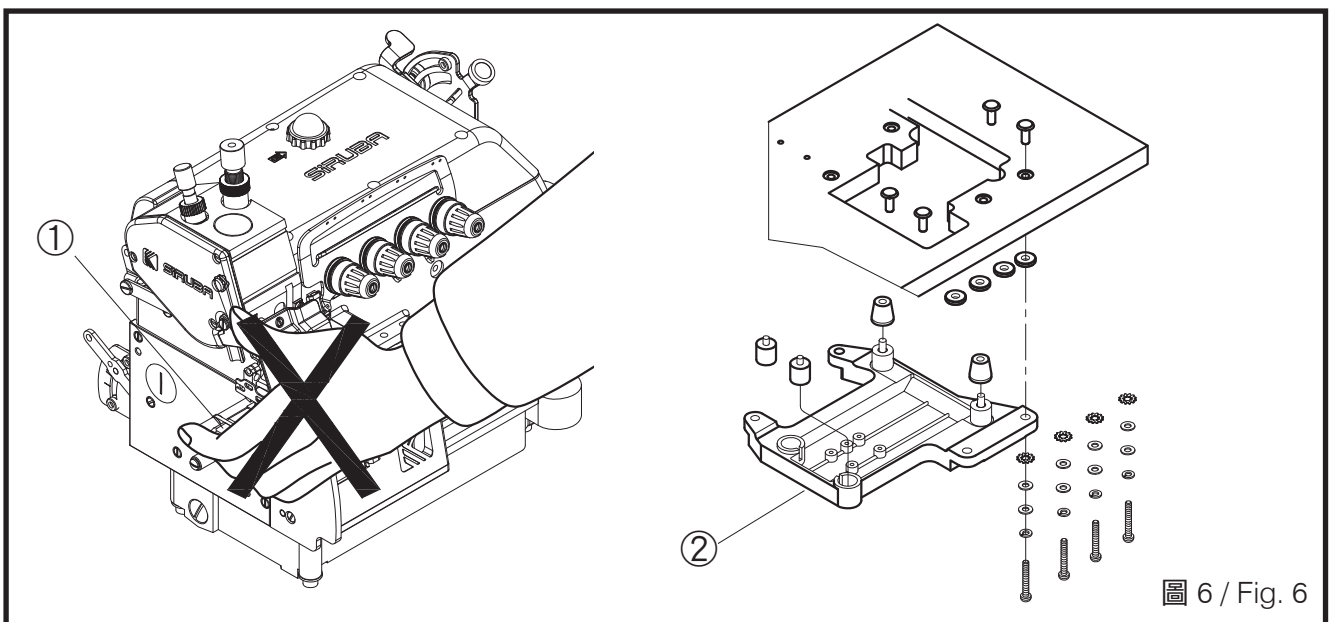
4. Install the motor activating plate ① to the left, and the presser pedal ② to the right. (Fig.8)

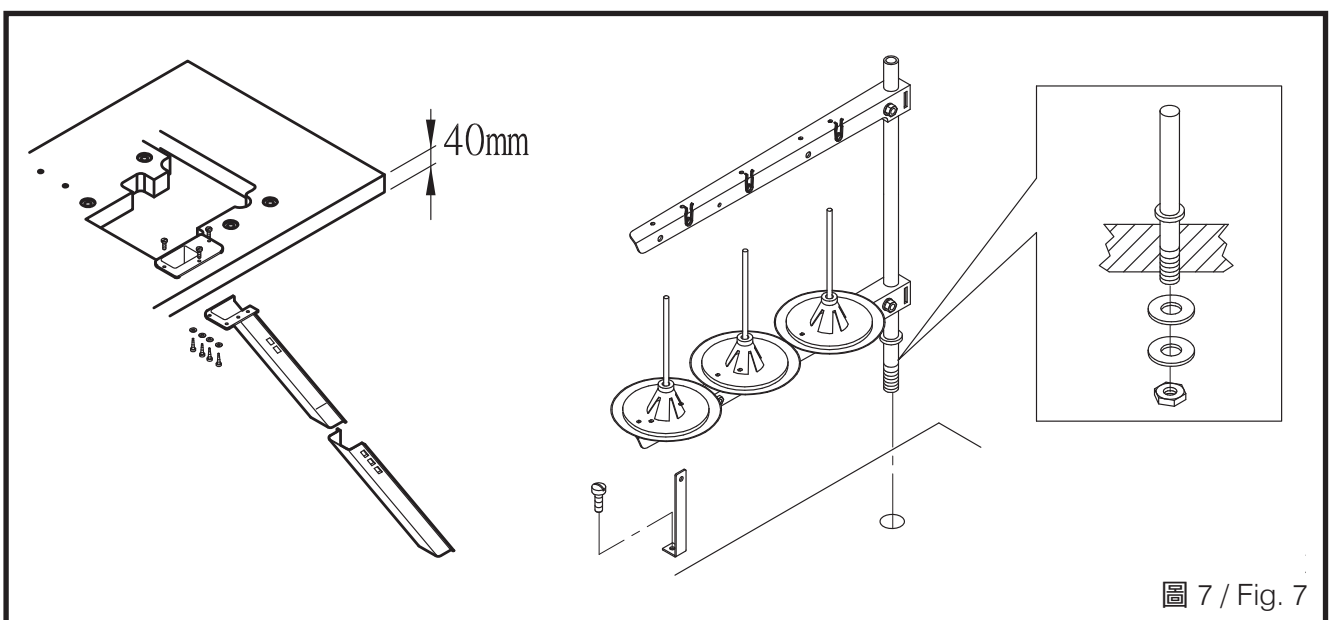
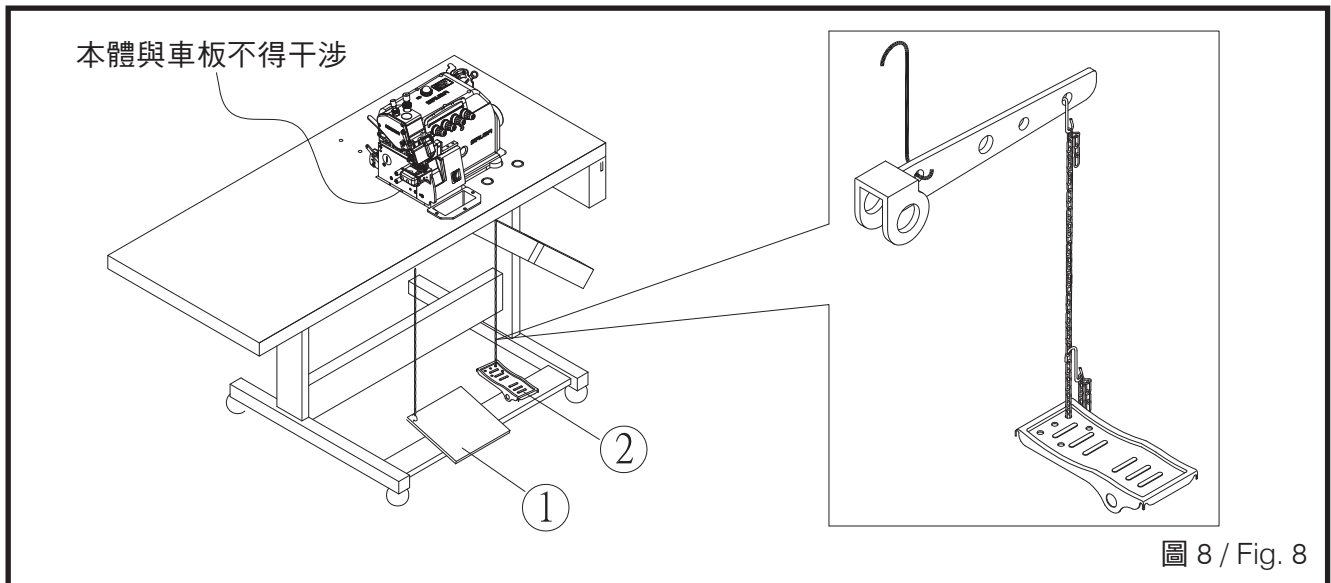

5. 注意馬達之轉向為順時鐘方向，皮帶①之鬆緊度以用手指向內壓下縮 10mm 之緊度為宜。(圖 9)
6. 確保使用者的安全一定要鎖上皮帶護蓋②。(圖 9)

5. Pay attention to the motor rotation which should be clockwise. The slackness of the belt ① should be 10mm pressed down by the finger. (Fig.9)
6. For the operators' safety, be sure to lock up the belt cover ②. (Fig.9)

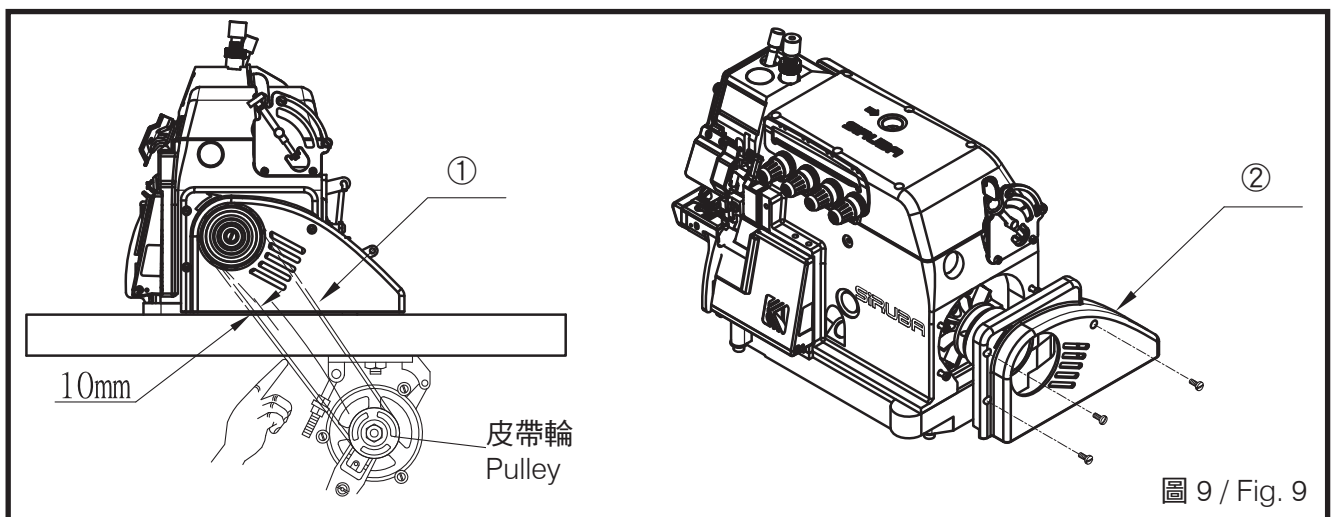

新機器啟用規定

1. 新機器在最初啟用磨合期的四個星期內，請用低於最高速度 20% 的速度運轉，之後換上新潤滑油，才可運轉至最高速度。
2. 定期之清潔保養，確保延長機器之使用壽命。

HOW TO OPERATE THE NEW MACHINE

1. Please operate this machine in 80% of the maximum speed in the first four weeks for engagement. After four weeks, please do not operate under the maximum speed until replacing the new lubrication oil.
2. Periodically maintain and clean the machine to ensure and extend the usage term of the machine.

潤滑油之注入與更換

1. 潤滑油之注入 (圖 10)
 - (1) 油鏡①旋開，以包裝箱內所附之超高速潤滑油或選用 MO BIL#10 或 AGIP # 32 等相當之機油加入，使油量指示桿位於油標上下之間即可，然後再鎖緊油鏡①。
 - (2) 開箱新機器或久置未使用時，請在針棒、上勾針台等加油潤滑。
2. 潤滑油之更換 (圖 10)
 - (1) 將螺絲②放鬆旋開，使油槽內的油完全排出後再鎖緊。
 - (2) 為延長本機器之壽命，請於開始使用後四星期更換新油，爾後約每四個月更換一次。

LUBRICATION AND DRAINAGE

- 1.Fill the lubrication oil (Fig.10)
 - (1)Remove the oil level inspection leng ①, and fill it with the attached ultra high speed lubricating oil, or choose MOBIL#10 or AGIP#32 equivalent. Tighten the oil level inspection leng ① after the oil level indicator locates between the two marking lines.
 - (2)Please lubricate the needle bar and the upper looper shaft before starting operating a new machine or a long idling machine.
- 2.Drainage and refill the oil (Fig. 10)
 - (1)Loosen the screw ② and drain all the oil inside the oil tank. Then, tighten the screw again.
 - (2)In order to extend the term of usage, please replace the oil after the first four week, and then replace it every four months.



圖 10/ Fig.10

(3) 為延長此機器之壽命，特別裝有濾油器之機構，請在每使用一個月後卸下清洗乾淨，必要時得更換新品。

3. 針之冷卻油使用油：矽油 (圖 11)

(3) To extend the usage term, this machine has equipped an oil filter. Please disassemble and clean it every month, as well as change it if needed.

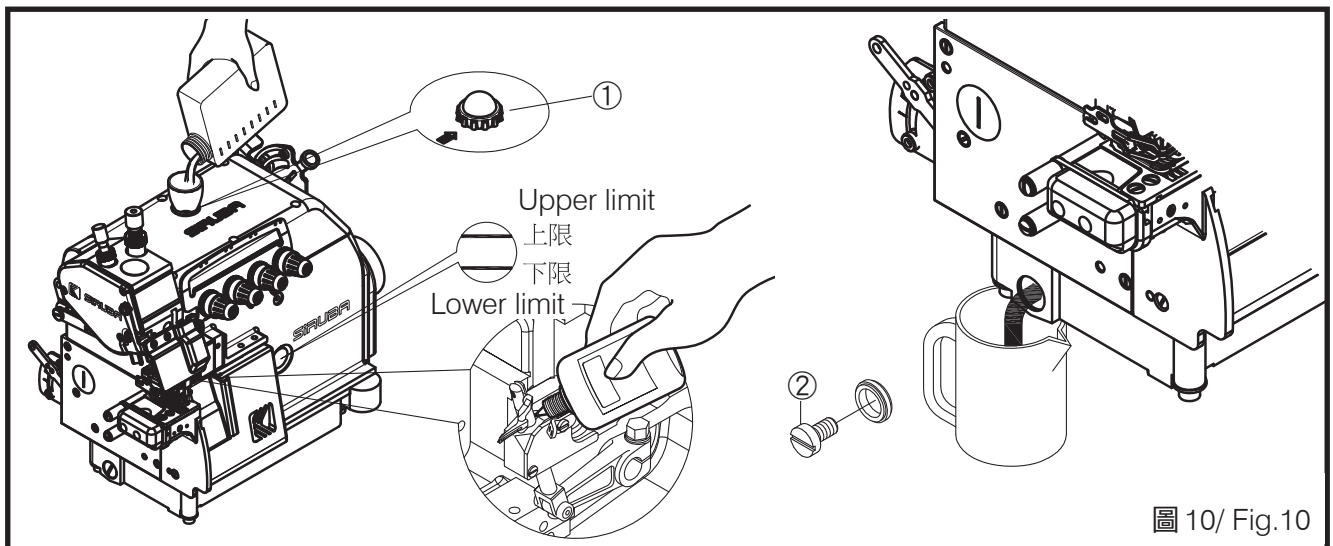
3. Needle cooling lubrication oil: SILICON OIL.
(Fig. 11)

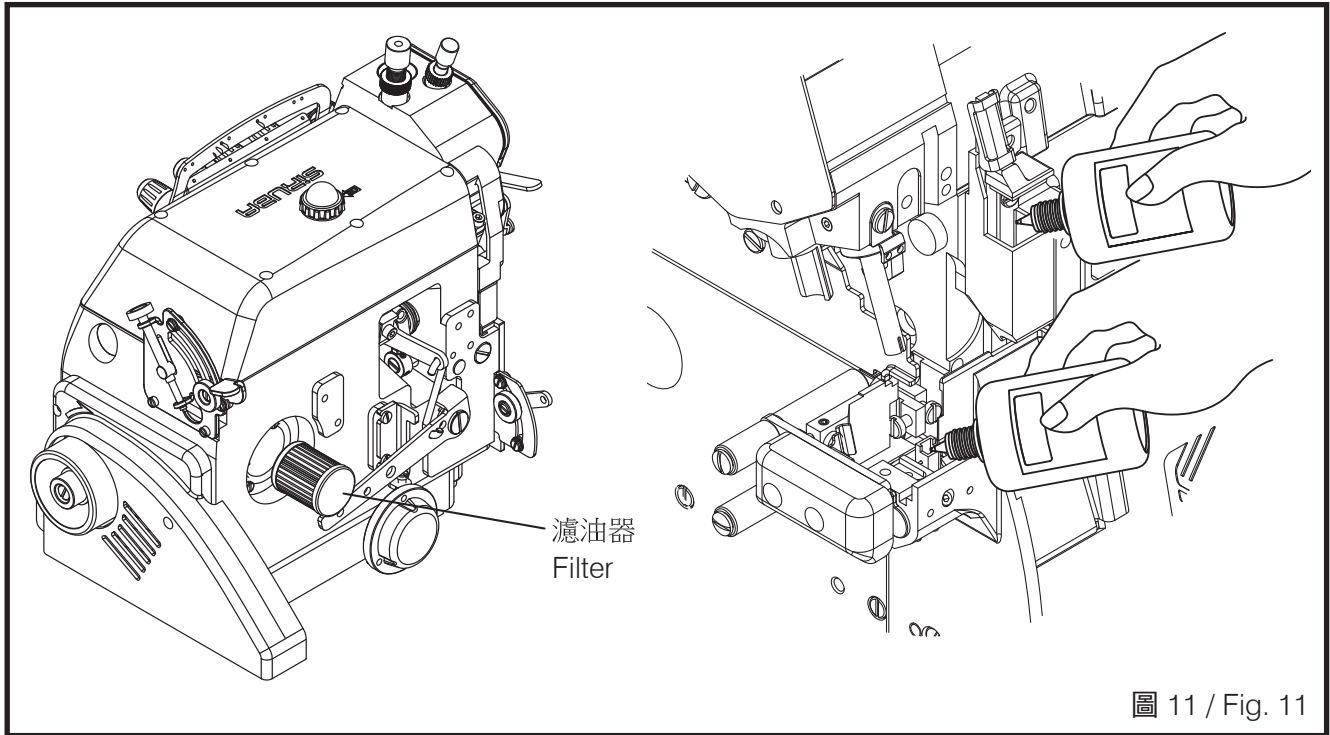

穿線方法

THREADING

請確實按照圖示穿線，錯誤之穿線將引起斷線、跳針及車縫不平坦...等現象。

Follow the procedures for threading. Wrong threading may cause thread breaking, stitch skipping, puckering or unexpected sewing.

1.737 用穿線圖 (圖 12)

1.For three thread only 737(Fig. 12)



圖 12 / Fig. 12

2.747 用穿線圖 (圖 13)

2.For three thread only 747(Fig. 13)

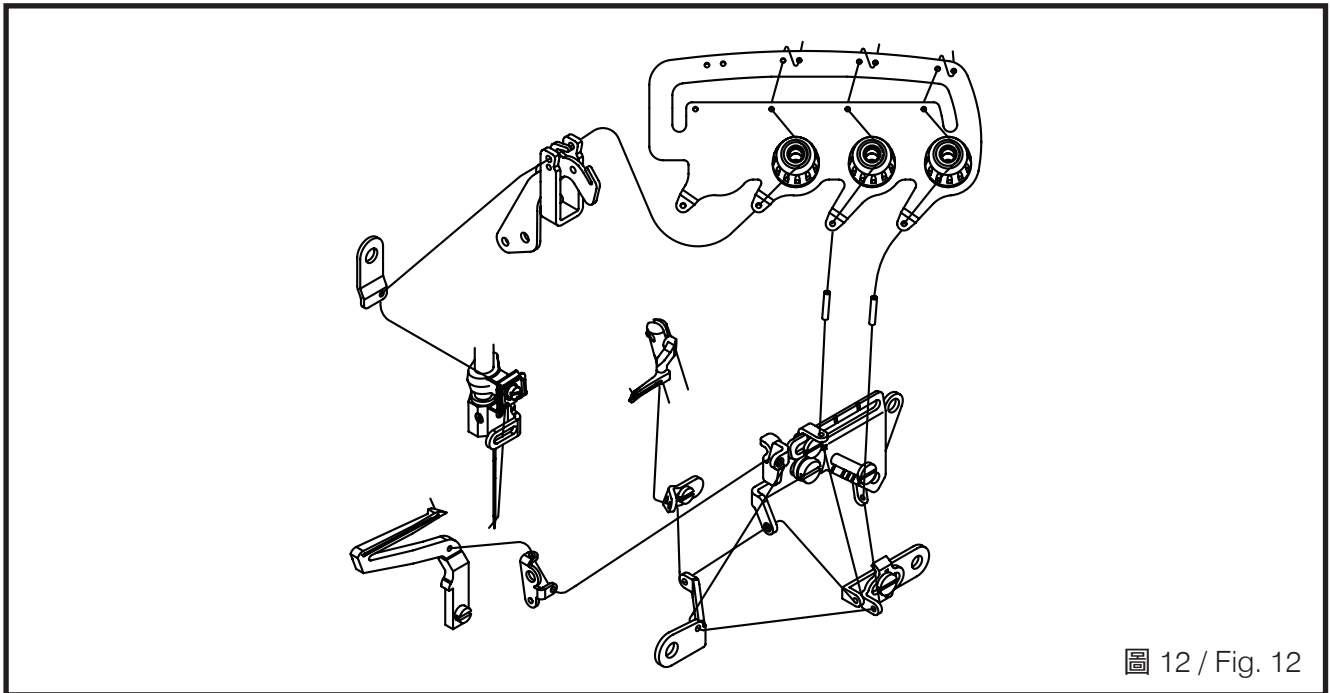

圖 13 / Fig. 13

控線調整

ADJUST THREAD TENSION

線張力必須根據縫合布料種類，布料厚薄，線及包邊寬度等之差異而做不同的調整。順時針旋轉張力控制螺帽，縫線張力加大，反之減弱。

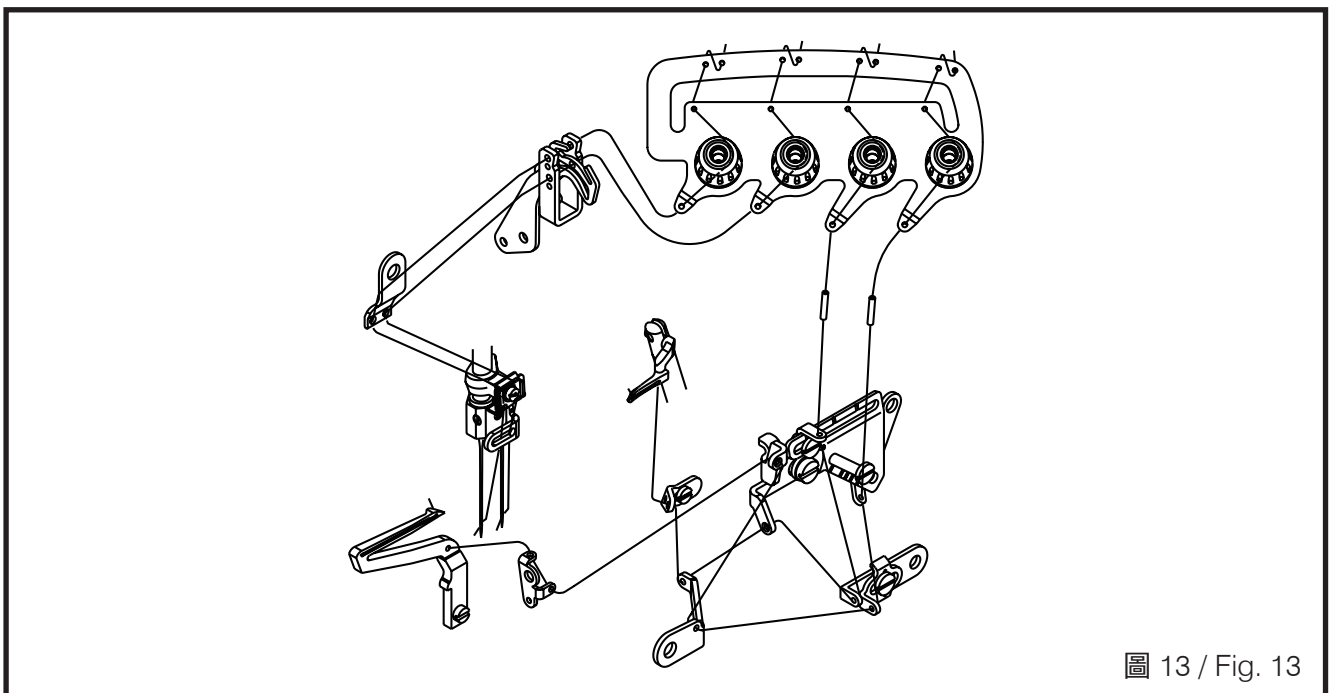
1. 調整鈕之控線關係 (圖 14)

- (1) 第一調整鈕①控制雙環針線或左邊拷克線
- (2) 第二調整鈕②控制包邊針線
- (3) 第三調整鈕③控制上勾針線
- (4) 第四調整鈕④控制下勾針線
- (5) 第五調整鈕⑤控制雙環勾針線

The thread tension should be adjusted properly according to the kinds and the thickness of the materials, stitch length, and seam width, etc. In addition, adjust the nuts case by case individually. Turn the nuts clockwise will increase the thread tension. Otherwise, the thread tension will be decreased

1. Thread tension adjusting nuts (Fig.14)

- (1)The first adjusting knob ① controls double chain stitch threads or the left over-lock needle thread.
- (2)The second adjusting knob ② controls the seam lock needle thread.
- (3)The third adjusting knob ③ controls the upper looper thread.
- (4)The fourth adjusting knob ④ controls the lower looper thread.
- (5)The fifth adjusting knob ⑤ controls the double chain looper thread.

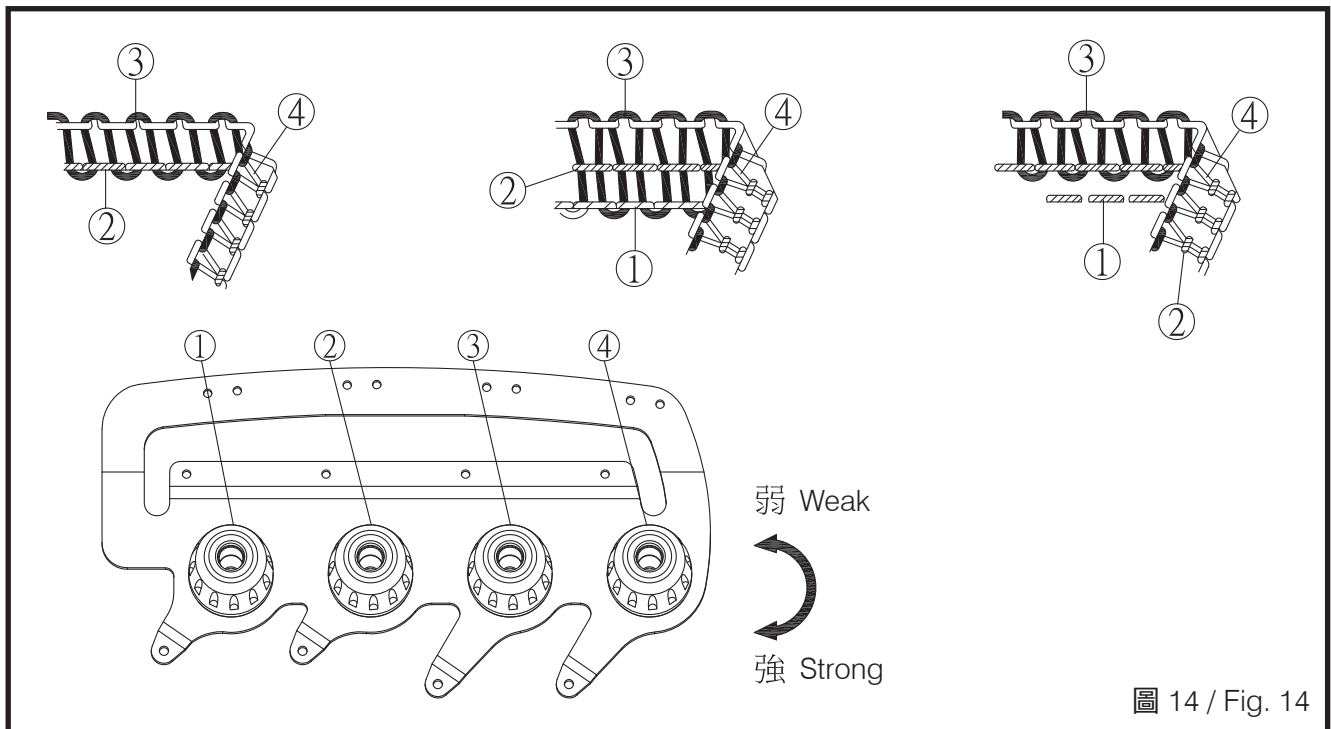

2. 針線控線關係 (圖 15)

- (1) 縫合方式 504、505、514 時，將過線組件 ① 移至最下端。
- (2) ⊕ 表示增加針線放線量。
- (3) ⊖ 表示減少針線放線量。

2.Relation of needle thread tension (Fig.15)

- (1)While doing the stitches, 504,505,514, move the eyelet ① to the bottom.
- (2) ⊕ indicates to increase the thread amount.
- (3) ⊖ indicates to decrease the thread amount.



圖 15 / Fig. 15

3. 勾針控線關係 (圖 16)

- (1) 若縫合方式為 504，514 及上勾針移至最低時，將 ① 往 ⊕ 位置微調。若縫合方式為 505 時，則往 ⊖ 端微調。
- (2) 固定線導板 ②、③ 如下：⊕ 方向為縫合線較多，反之較少。

3.Looper thread control(Fig.16)

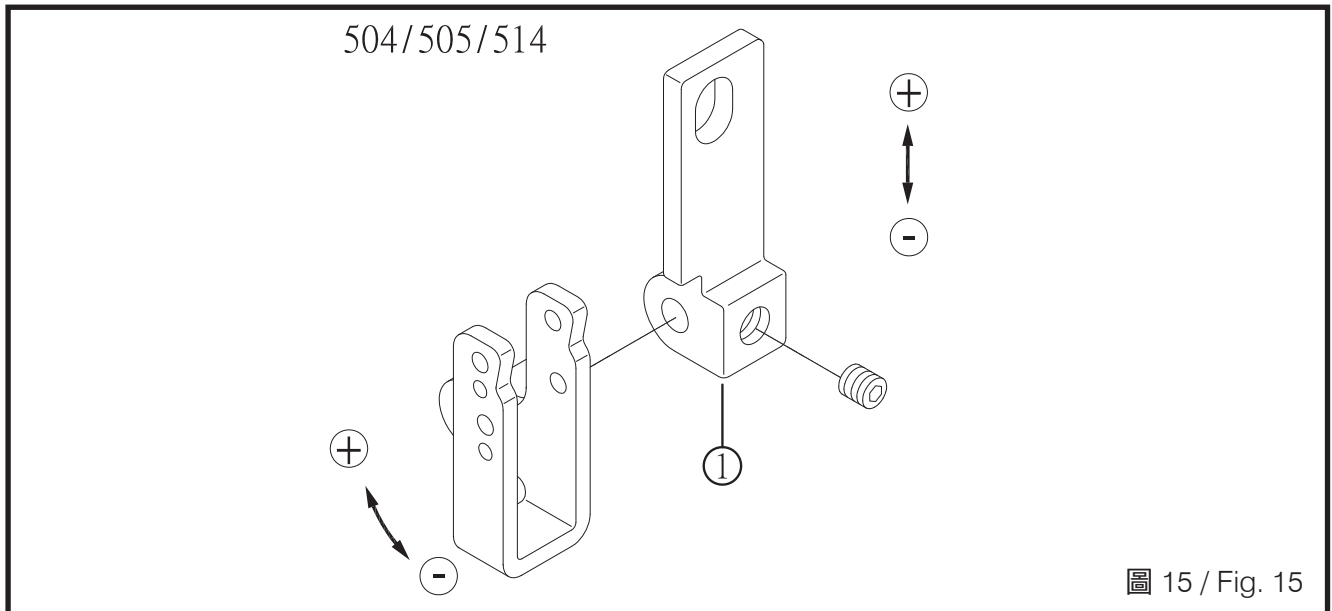
- (1)When the sewing type is 504, 514, and the upper looper is on the lowest point, adjust ① at the position of ⊕. When the sewing type is 505, set the take-up ① at the position of ⊖.
- (2)Adjust fixed thread guide plate ② and ③ as the following: The direction ⊕ is for more thread in sewing seam, and the ⊖ direction is for less thread in sewing seam.



圖 16 / Fig. 16

換針方法

1. 使用 DCX27 或同規格之針。
2. 旋開螺絲①並取下針。
3. 將新針插至針孔最底端，並使針之長溝面向自己，固定螺絲①。(圖 17)

REPLACE THE NEEDLE

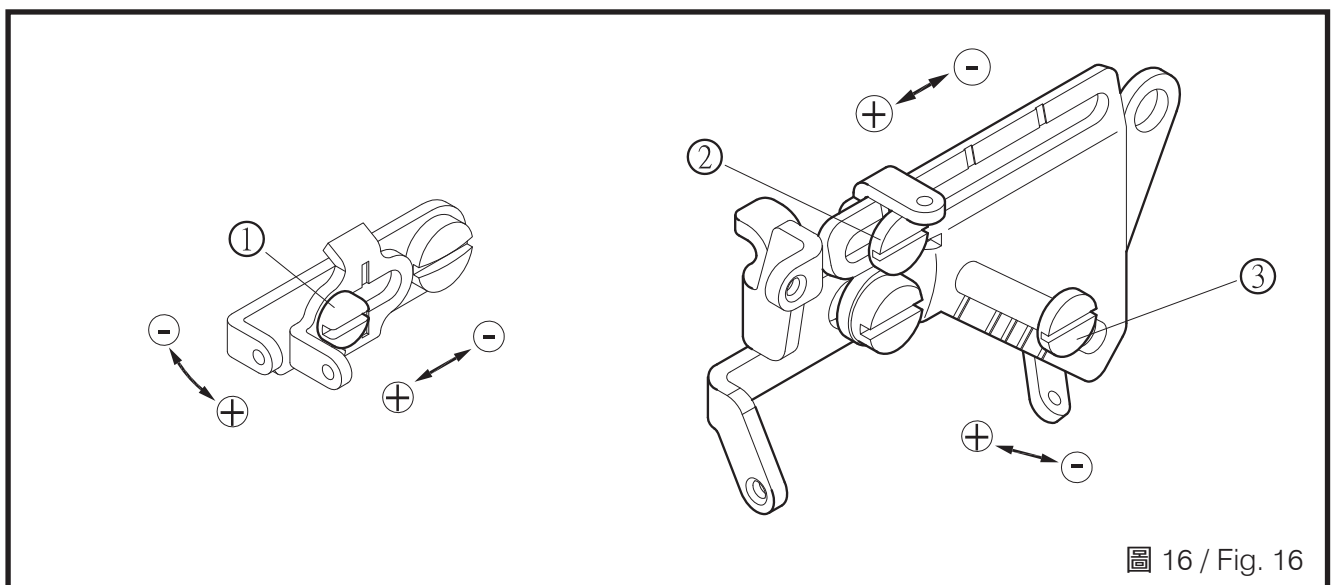
1. Please use the needle DCX27 or the equivalents.
2. Loosen the screw ① and take off the needle.
3. Insert the new needle till reaching the end, as well as the long groove faces your side. Tighten the screw ①. (Fig.17)

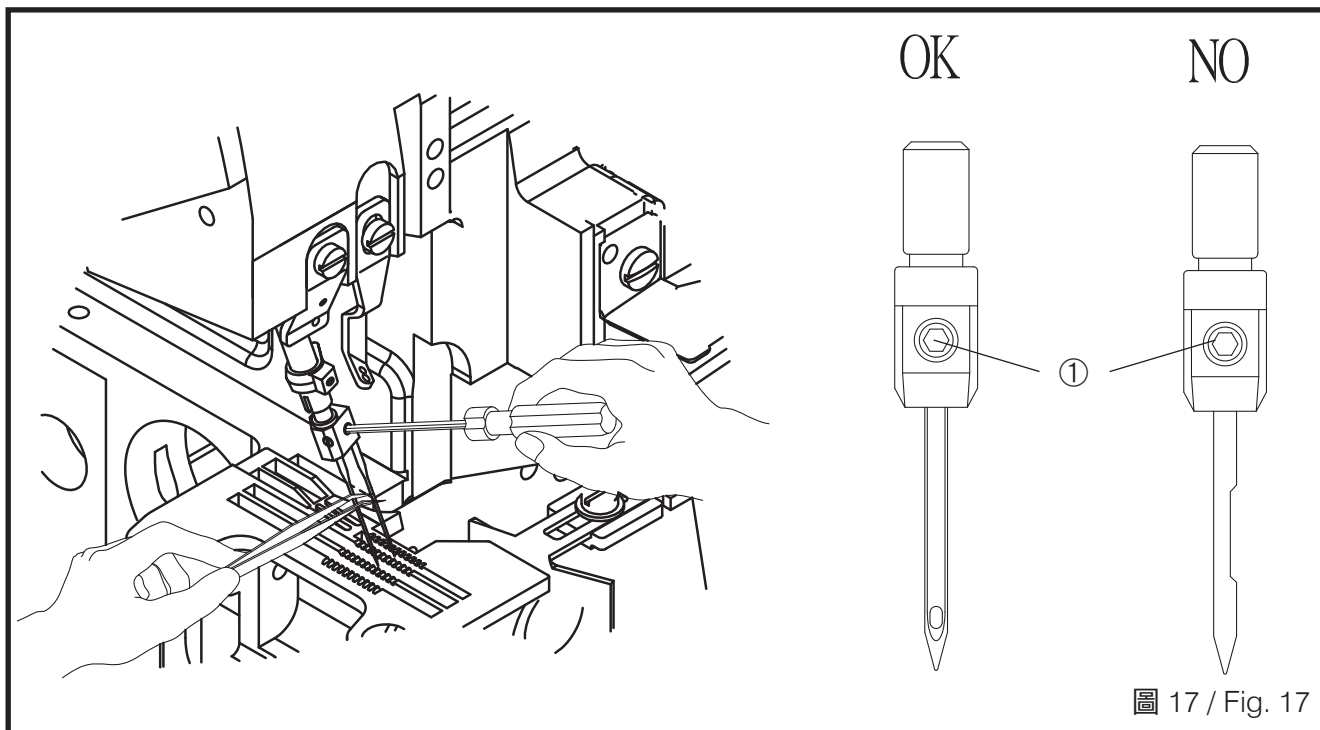

針距調整

通常依縫合布料，差動比等之不同而調整。持續壓下按鈕①並轉動手輪使鈕卡住，轉動手輪至所需之針距後放開此按鈕。(表 2)(圖 18)

ADJUST THE STITCH LENGTH

The stitch length is adjusted according to the fabrics, the differential ratio or other factors. Keep pressing the button ① and turn the pulley till the button is locked. Then, release the button after reaching the desired stitch length.(Table2)(Fig.18)

最大差動比 Maxi Diff ratio	機種 Machine type	皮帶輪刻度 Pulley scale						
		1	2	3	4	5	6	7
1:1.3	包邊 Serging	0.8	1.5	2.2	2.9	3.6	4.3	5
1:2	接縫 Seaming	0.6	1.13	1.66	2.19	2.72	3.25	3.8
1:3	摺縫 Shirring	0.6	1.03	1.46	1.89	2.32	2.71	3.2
1:4	特規 Special	0.6	1.02	1.44	1.66	2.88	2.7	-

表 2 / Table2



圖 18 / Fig. 18

差動比調整

ADJUST THE DIFFERENTIAL FEED RATIO

若主送具之運動行程大於差動送具運動行程時，布料車縫時會伸張，反之則會收縮。

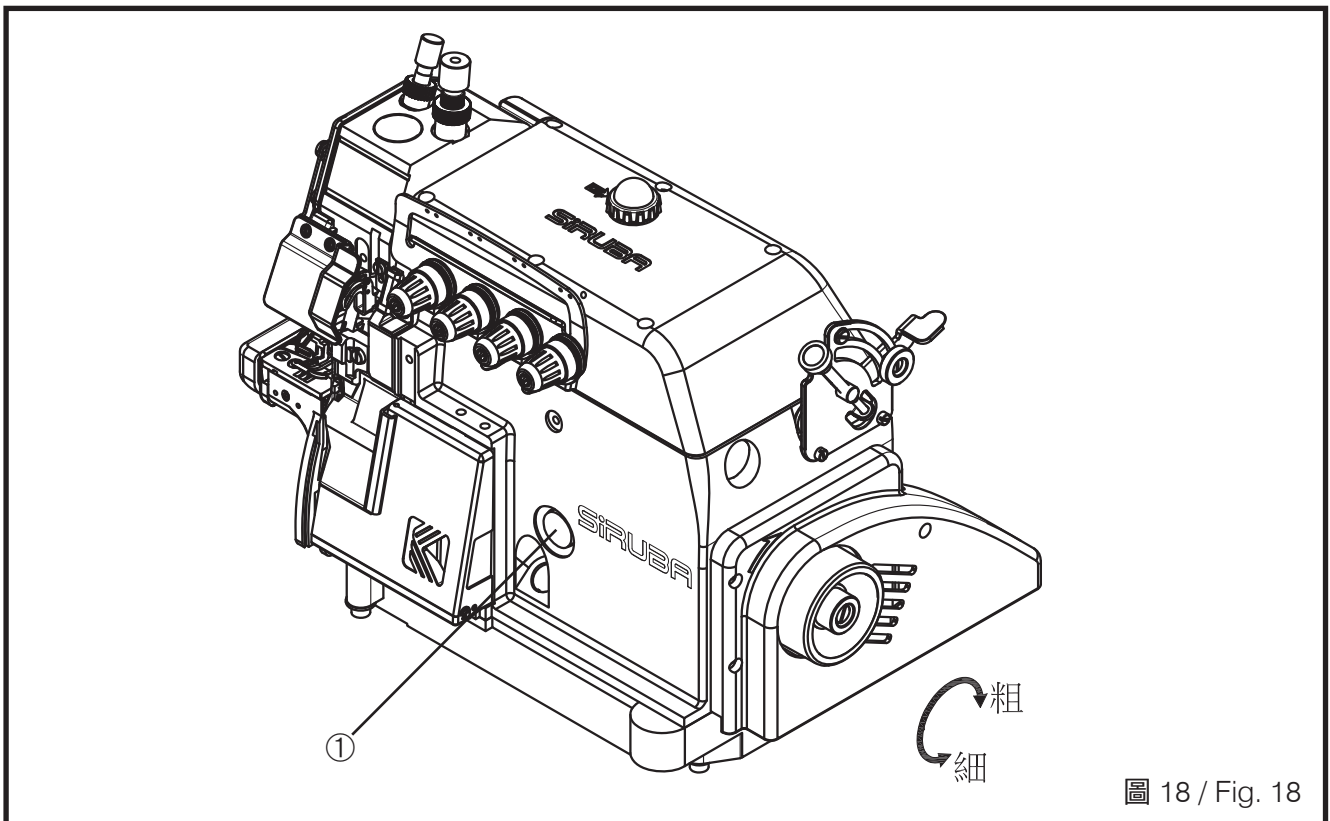
1. 調整方法一：

放鬆調整鈕①，當調整桿②向下調整時使布料收縮，反之則伸張，調整後再鎖調整鈕①。

(圖 19)(表 3)

If the stroke of the main feed dog is larger than the stroke of the differential feed dog, the fabric will be extended while sewing. Otherwise, it will be shrunk

1.Adjust solution 1:

Loosen the adjusting nut ①. Adjust the adjusting rod ② downward will shrink the fabric, whereas move it upward will extend the fabric. Tighten the adjusting nut ① after the adjustment finishes. (Fig.19)(Table3)

刻度 Scale		1	2	3	4	5
差動傳送比 Differential feed ratio	1:1.3	-	1:0.7	1:0.9	1:1.1	1:1.3
	1:2	1:0.7	1:1	1:1.14	1:1.17	1:2
	1:3	1:1	1:1.5	1:2	1:2.5	1:3
	1:4	1:1.1	1:1.6	1:2.3	1:2.3	1:3.3

表 3 / Table3



圖 19 / Fig. 19

2. 調整方法二：

- (1) 鬆開蓋板①。
- (2) 鬆開螺絲②，上下移動連桿③欲增加行程，把連桿③往 (+) 方向移動；欲減少行程，把連桿③往 (-) 方向移動。
- (3) 在調整過後，把蓋板①鎖回。(圖 20)

2.Adjusting manner2:

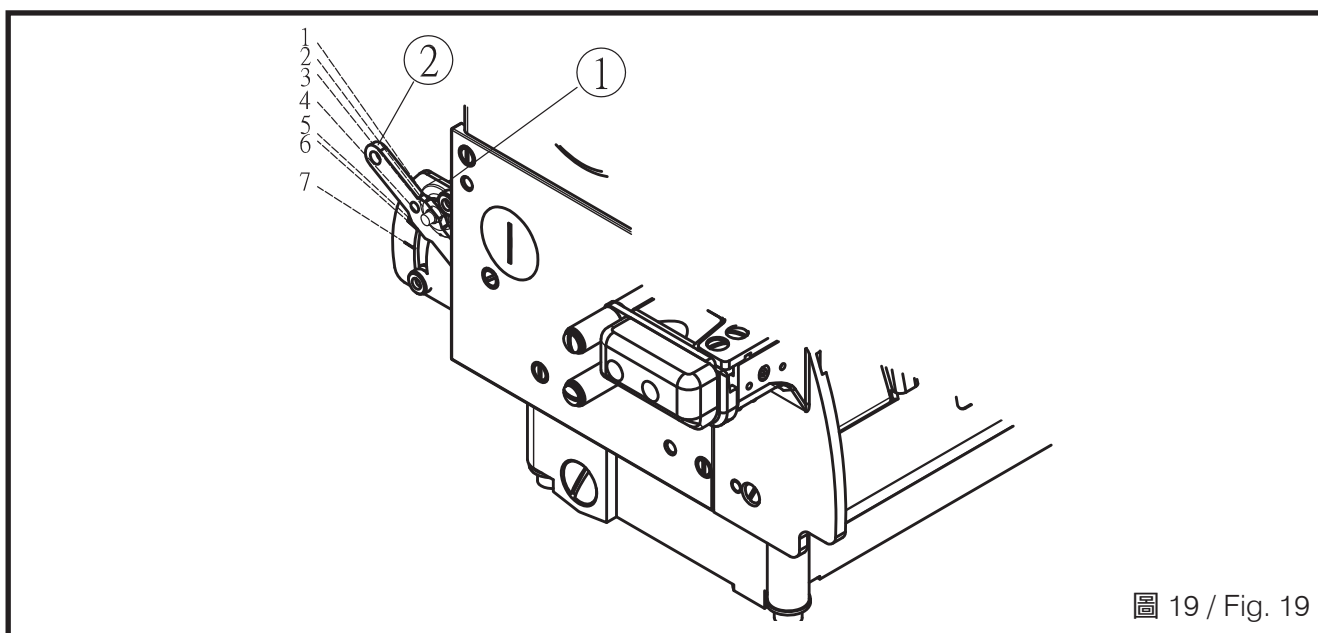
- (1) Loosen the cover board ①.
- (2) Loosen the screw ②. Move the lever ③ up and down. To increase the stroke, move the lever ③ to the (+) direction. To decrease the stroke, move the lever ③ to the (-) direction.
- (3) After adjusting, tighten the cover board ①. (Fig.20)



圖 20 / Fig. 20

更換切刀

1. 更換上切刀 (圖 21)
 - (1) 取下螺絲①將上刀座②移出，鬆開螺絲③，更換刀片④。
 - (2) 轉動皮帶輪使上刀移至下死點，調整上刀高低使上刀與下刀相交約 0.5~1.0mm，鎖緊螺絲③。
 - (3) 試驗上下刀能確實剪斷車縫線。
2. 更換下切刀 (圖 21)
 - (1) 放鬆螺絲⑤將下刀座⑦向右移出。
 - (2) 放鬆螺絲⑥及固定片⑧更換刀片⑨。
 - (3) 將下刀座向左推回，調整下刀之刀口與針板面平齊後，鎖緊螺絲⑤。
 - (4) 試驗上下刀能確實剪斷車縫線。

REPLACE THE TRIMMERS

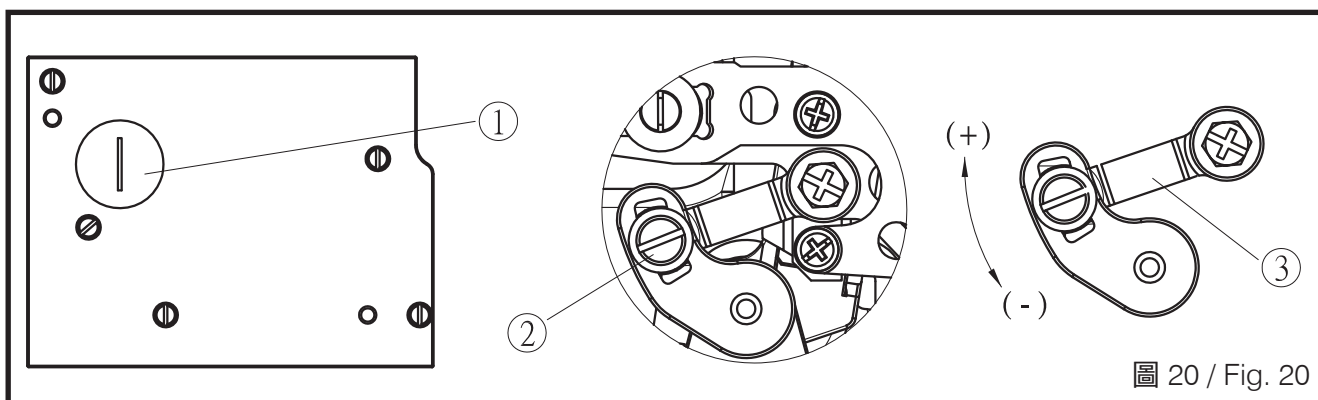
1. Replace the upper knife (Fig.21)
 - (1) Take down the screw ① and move out the upper knife bracket ②. Loosen the screw ③ and replace the knife ④.
 - (2) Turn the pulley to move the upper knife to the bottom dead point. Adjust the height of the upper knife, and make the engagement between the upper and lower knives to be 0.5~1.0mm. Then, tighten the screw ③.
 - (3) Test the upper and lower knives to cut the thread.
2. Replace the lower knife (Fig.21)
 - (1) Loosen the screw ⑤ and move the lower knife bracket ⑦ rightward.
 - (2) Loosen the screw ⑥ and the fixed plate ⑧ and replace the knife ⑨.
 - (3) Push the lower knife bracket back. Align the blade of the lower knife to the needle plate, and then tighten the screw ⑤.
 - (4) Test the upper and lower knives to cut the thread.

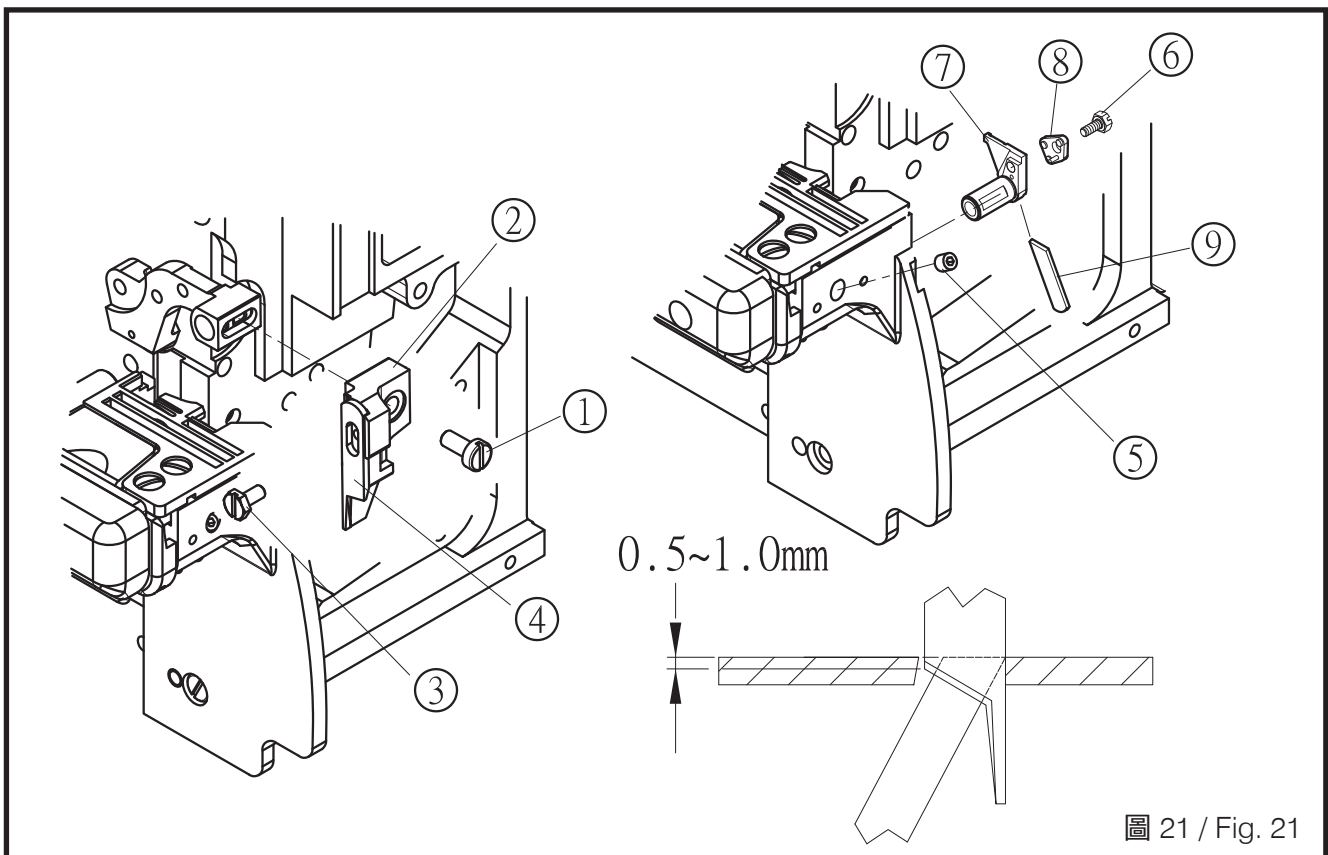

針高度之調整

1. 轉動皮帶輪使針上昇至最高點時，針尖至針板面之距離為 (a)。(圖 22)
2. 調整：
 - (1) 打開上蓋①。
 - (2) 放鬆螺絲②，移動針棒至所需高度鎖緊螺絲②。
 - (3) 回覆上蓋須密合鎖緊。

ADJUST THE NEEDLE HEIGHT

1. Turn the pulley to raise the needle to the top point. The distance between the tip of the needle to the needle plate is (a). (Fig.22)
2. Adjustment:
 - (1) Open the upper cover ①.
 - (2) Loosen the screw ②, and move the needle bar to the required height. Then, tighten the screw ②.
 - (3) Put the upper cover back and lock it closely.



圖 22 / Fig. 22

押具調整

1. 押具位置調整
 - (1) 放鬆押具壓力①及押具螺絲②。
 - (2) 移動押具③使其押具槽與針板之針槽一致 押具底平押於針板上，鎖緊螺絲②。
 - (3) 放鬆螺絲④左右移動⑤，使⑥與⑦吻合，且⑥能上下活動輕順，鎖緊螺絲④。
 - (4) 調整適當壓力，螺絲①順時針方向旋轉，壓力加大，反之減弱。(圖 23)

ADJUST THE PRESSER FOOT

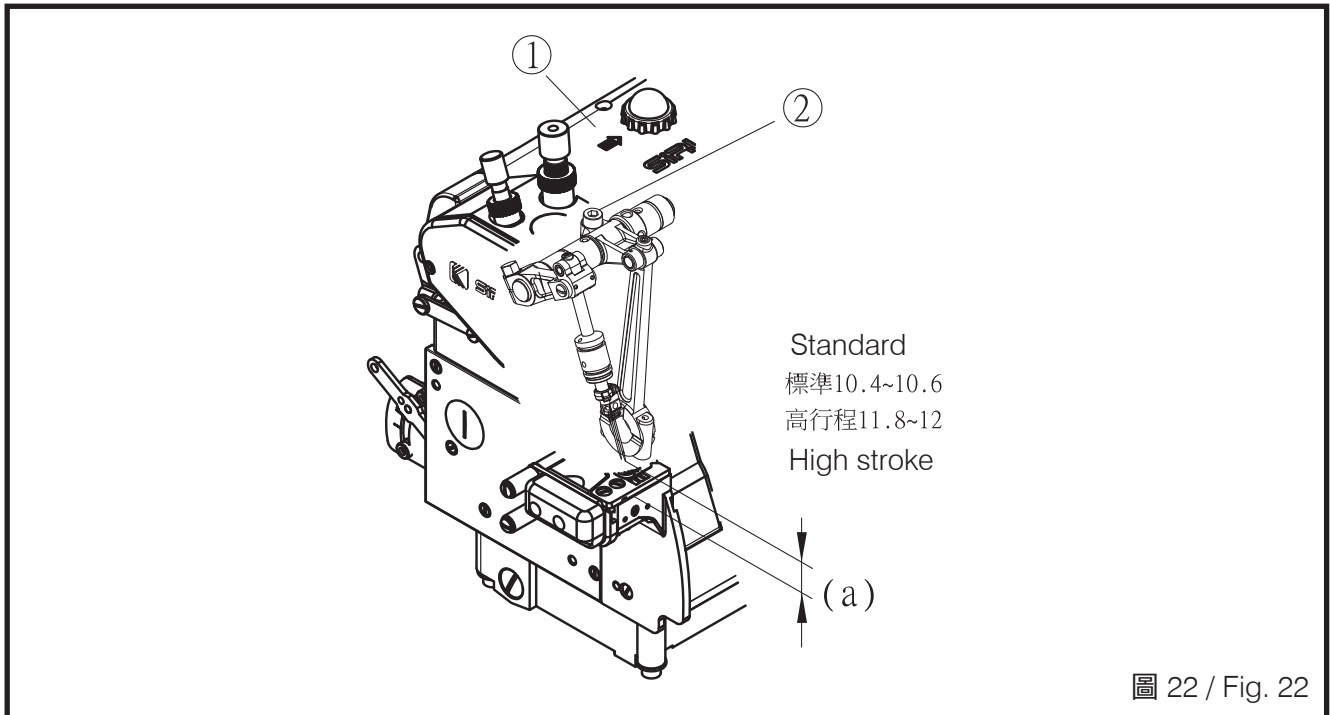
1. Adjust the position of the presser
 - (1) Loosen the pressure of the presser ① and the screw of the presser ②.
 - (2) Move the presser ③ to align the groove of the needle plate and the groove of the presser. The bottom side of the presser touches the needle plate flatly. Then, tighten the screw ②.
 - (3) Loosen the screw ④ and move ⑤ right-left to engage ⑥ with ⑦ and ⑥ could move smoothly. Then, tighten the screw ④.
 - (4) Adjust the appropriate pressure. Turn the screw ① clockwise to enlarge the pressure. The opposite way lowers down the pressure. (Fig.23)



圖 23 / Fig. 23

2. 押具提升量調整

- (1) 轉動皮帶輪使送具降至針板下，押具底平貼針板。
- (2) 放鬆螺帽①，壓下拉桿②使押具⑦ 上昇至適當位置約 5.0~5.5mm，調整螺絲③及固定螺帽①。
- (3) 拉桿④與固定座⑤須保持有 1mm 的間隙可輕輕放鬆螺絲⑥調整。
- (4) 要確實鎖緊螺絲⑥。(圖 24)

2. Adjust the arising amount of the presser

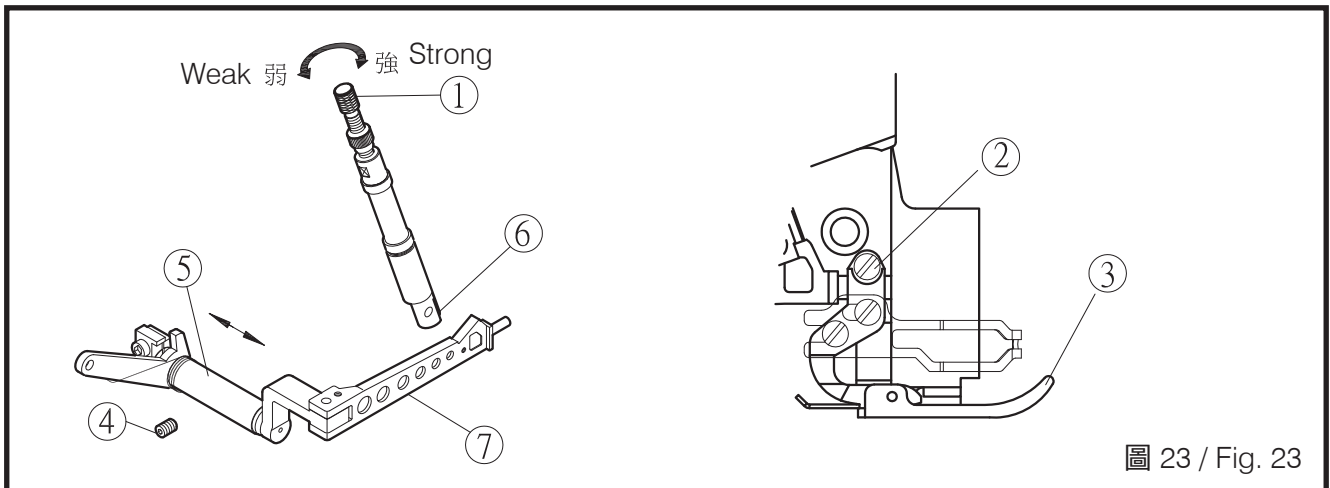
- (1) Turn the pulley to lower feed dog down under the needle plate. The bottom side of the presser touches the needle plate flatly.
- (2) Loosen the nut ①, push down the lever ② to arise the presser ⑦ to the appropriate position, around 5.0 ~5.5mm. Adjust the screw ③ and fix the nut ①.
- (3) Maintain the clearance between the lever ④ and the fixed plate ⑤ to be 1mm. Loose the screw ⑥ to adjust.
- (4) Then, tighten the screw ⑥ firmly. (Fig.24)



圖 24 / Fig. 24

送具調整

ADJUST THE FEED DOG

1. 送具高度調整 (圖 25)

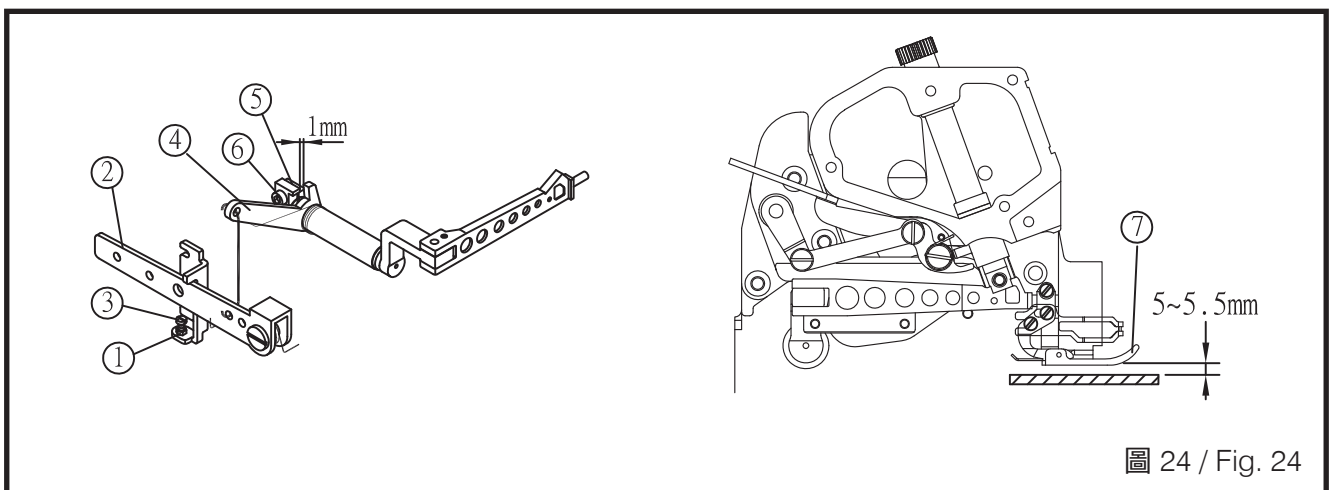
- (1) 轉動皮帶輪使送具上升至針板上最高點。
- (2) 放鬆螺絲①，上下移動主送具②，使其齒面高出針板面約 0.8 ~ 1.0mm，鎖緊螺絲①。
- (3) 放鬆螺絲③，上下移動差動送具④使其齒面高出針板面約 0.8 ~ 1.0mm 鎖緊螺絲③。

1. Adjust the feed dog height (Fig.25)

- (1) Rotate the pulley to rise the feed dog the highest point of the needle plate.
- (2) Loosen the screw ①, and move the main feed dog ② up and down in order to keep the teeth side over the needle plate about 0.8 ~ 1.0mm. Then tighten the screw ①.
- (3) Loosen the screw ③, and move the differential feed dog ④ up and down in order to keep the teeth side over the needle plate about 0.8 ~ 1.0mm. Then, tighten the screw ③.

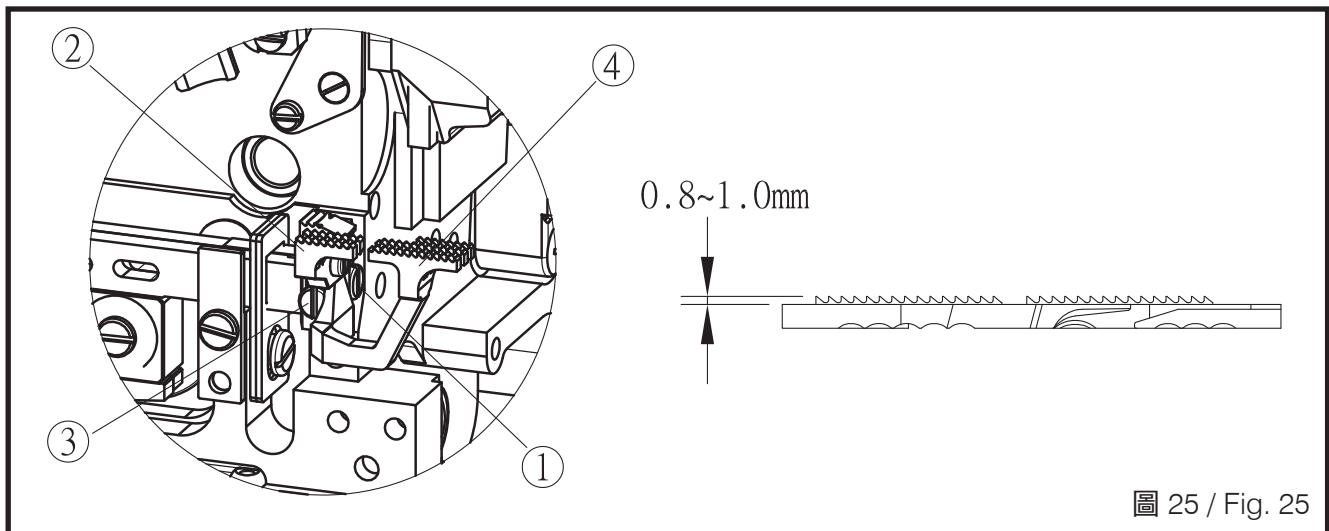

2. 送具水平調整

- (1) 當送料桿升至最高點時，送具齒面必須由前向後傾斜。
- (2) 調整時放鬆螺絲①②，轉動螺絲③進行調整，齒面呈水平後固定螺絲①②。(圖 26)

2. Adjust the level of the feed dog

- (1) When raising the feed bar to the highest point, the side of the feed teeth must be tilted from the front to the back.
- (2) Loosen the screw ①②, turn the screw ③ to adjust. Make the side of the feed teeth and then tighten the screw ①②. (Fig.26)



圖 26 / Fig. 26

3. 輔助送布齒高度

輔助送具①，其齒面比送布齒齒面低
0.1~0.3mm，可放鬆螺絲②來調整。
(圖 27)

3. The height of the auxiliary feed teeth

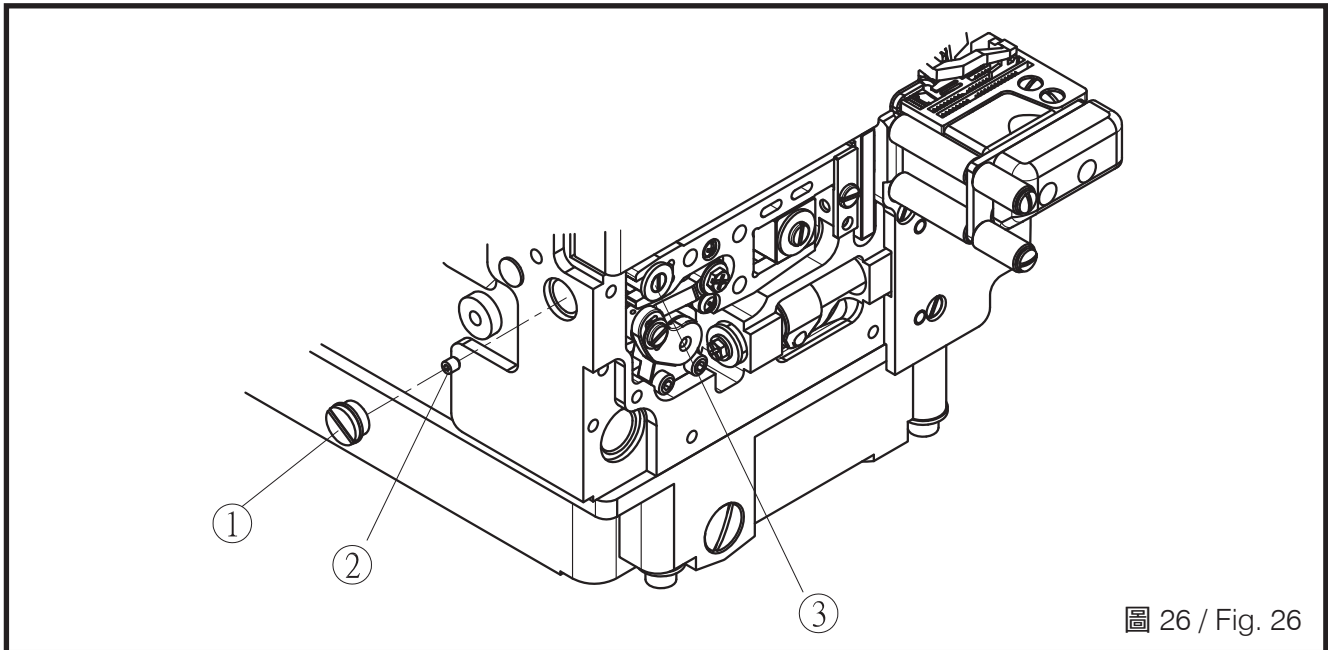
The auxiliary feed dog 1, the side of teeth
is lower 0.1~0.3mm than the teeth side of
the feeder. Loosen the screw 2 to adjust.
(Fig.27)



圖 27 / Fig. 27

4. 主送布齒與針板之關係

當設定送料量為最大時，需確認主送齒與針
板狹縫留有 0.8mm 的距離。(圖 28)

4. Relation between the main feeder and the needle plate

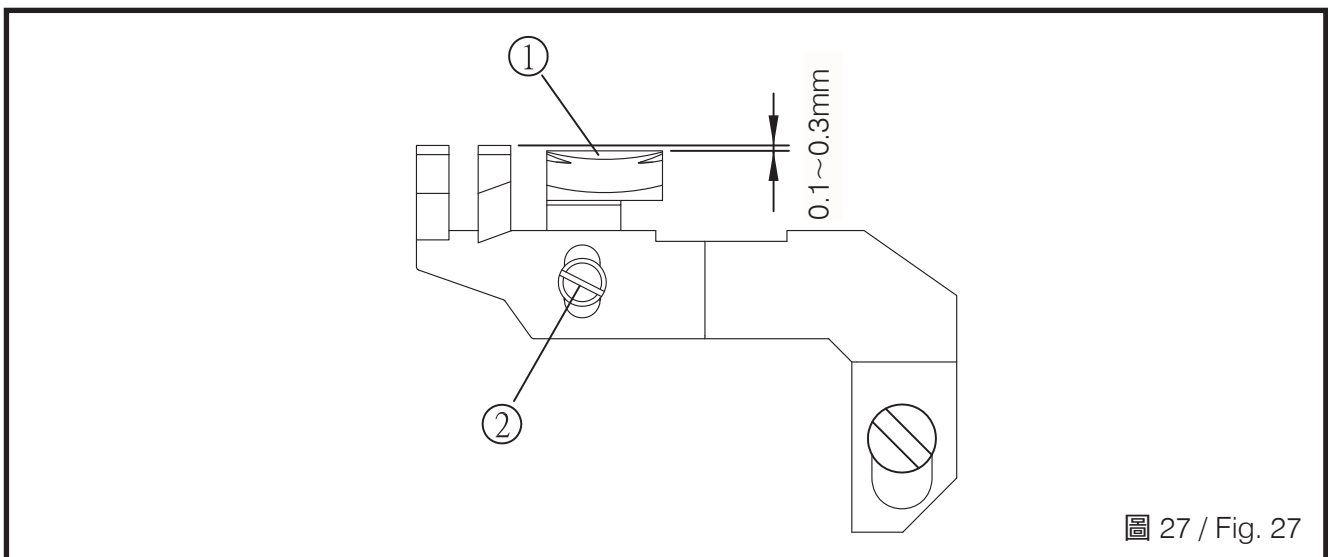
When setting the feeding amount is the
largest, it is necessary to confirm the
distance between the main feeder and the
needle plate is 0.8mm. (Fig.28)



圖 28 / Fig. 28

針與勾針之關係

THE RELATIONSHIP BETWEEN NEEDLE AND LOOPER

1. 針與上勾針之關係

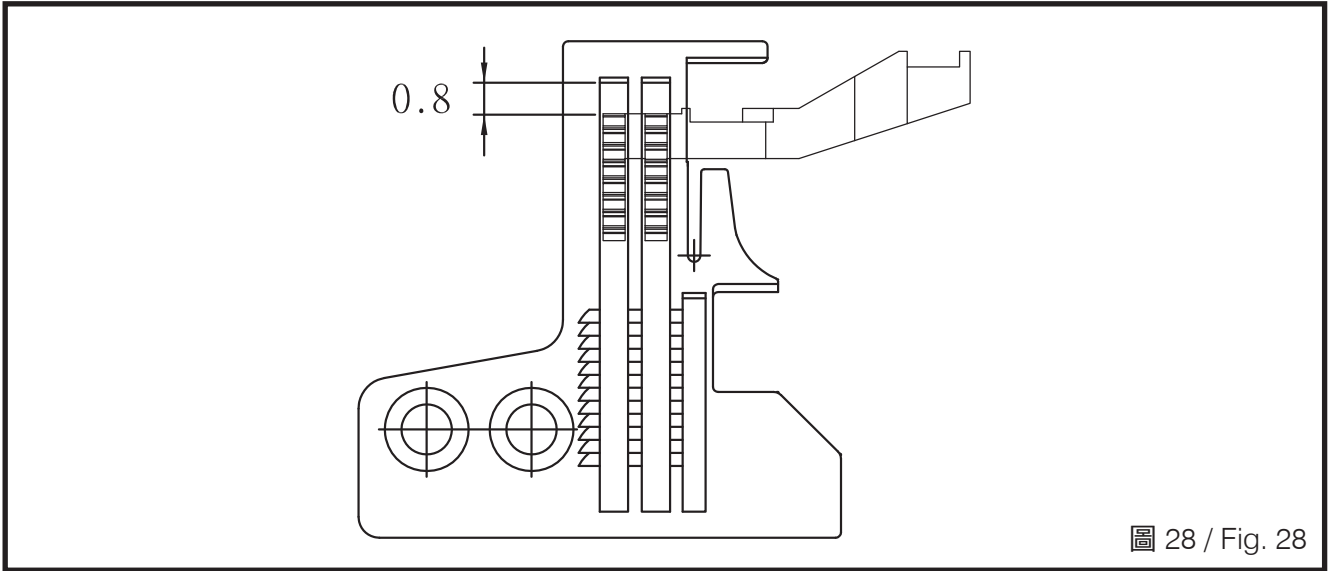
當上勾針移至最左時，勾針尖端與針中心距約 4.4 ~ 4.7mm，雙針時其左針中心與勾針尖端距約 5.4 ~ 5.7mm。(圖 29)

1. The relationship between the needle and the upper looper

When the upper looper moves to the leftest point, the distance from the looper tip to the middle line of the needle is 4.4 ~ 4.7mm. For double needles model, the distance from the looper tip to the middle line of the left needle is 5.4 ~ 5.7mm.(Fig.29)



圖 29 / Fig. 29

2. 針與下勾針之關係

- (1) 當下勾針移至最左時，勾針尖端與針中心距約 2.8~3.0mm(雙針時以左針為主)。(圖 30)

2. Relation between the needle and the looper

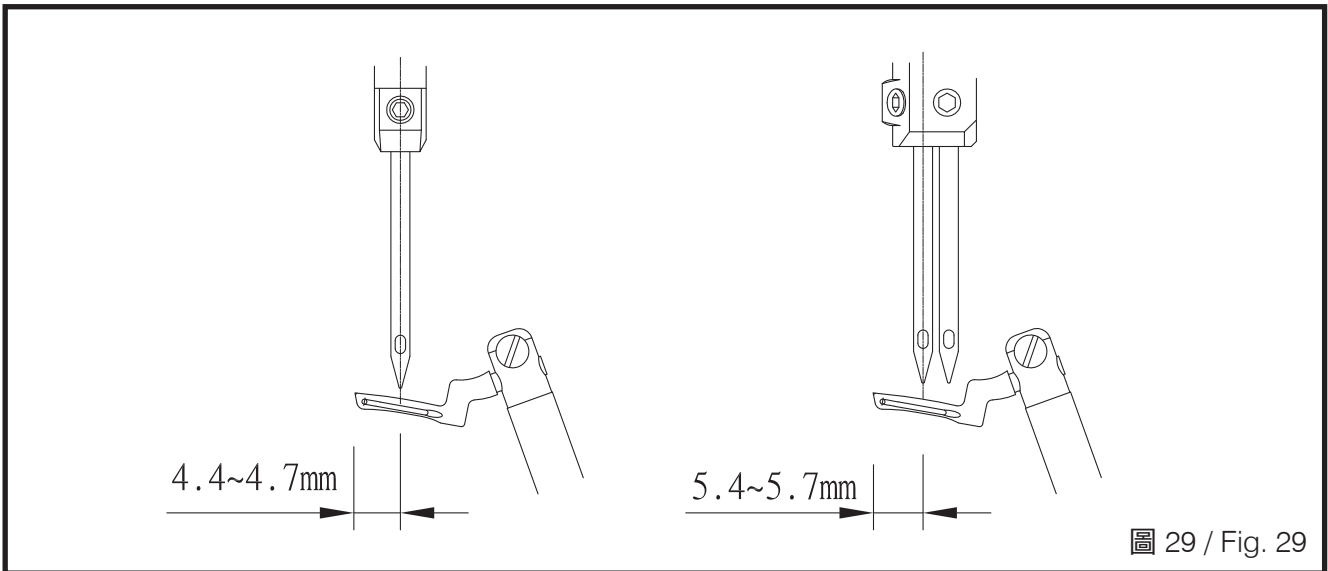
- (1) The distance between the tip of the looper and the center of the needle should be 2.8~3.0mm when the lower looper moves the extreme left. (The left needle is main while using double needles) (Fig.30)



圖 30 / Fig. 30

- (2) 依照桌板，調整下勾針 A 的距離設定，下勾針會從第一針孔穿過 1.3mm 的位置。(圖 31)
- (3) 當下勾針向右移至針中心時(雙針以左針)針與勾針之間隙為 0~0.05mm。(圖 31)

- (2) Based on the table, adjust the distance setting of the lower looper A. The lower looper will pass from the first needle hole through the position of 1.3mm. (Fig.31)
- (3) The clearance between the needle and the looper is 0~0.05mm, when the lower looper moves rightward to the center of the needle (The left needle is main while using double needles) (Fig.31)

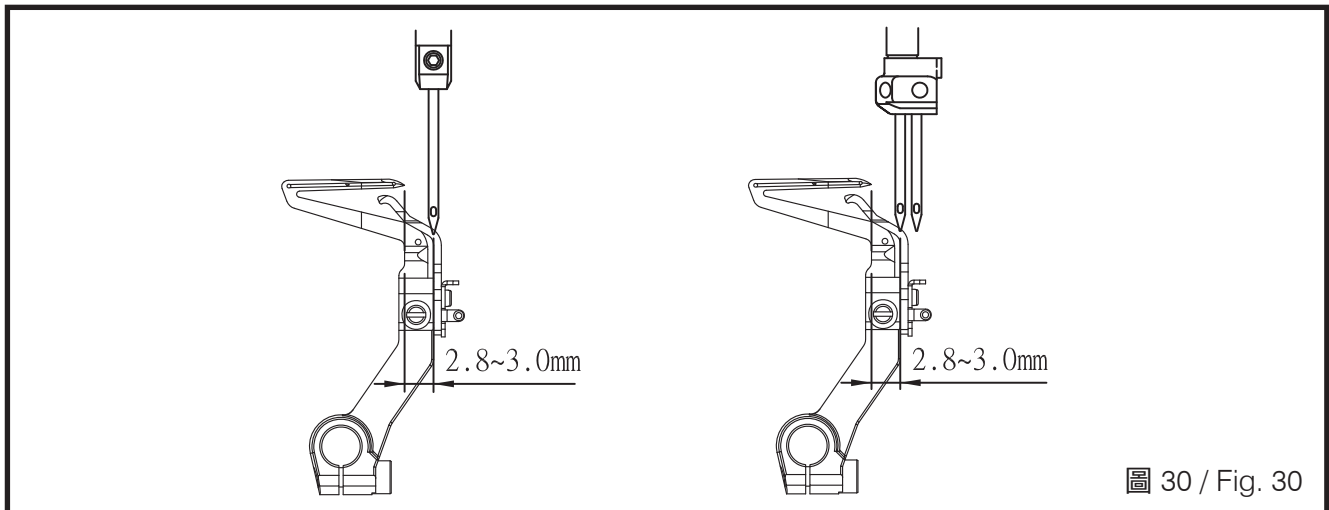

圖 31 / Fig. 31

3. 上勾針與下勾針之關係

當上下勾針相交時，兩勾針盡量接近，但不可磨擦或碰撞，其間隙 A 點為 0.5mm B 點為 0.2mm。(圖 32)

3. Relation between the upper looper and the lower looper

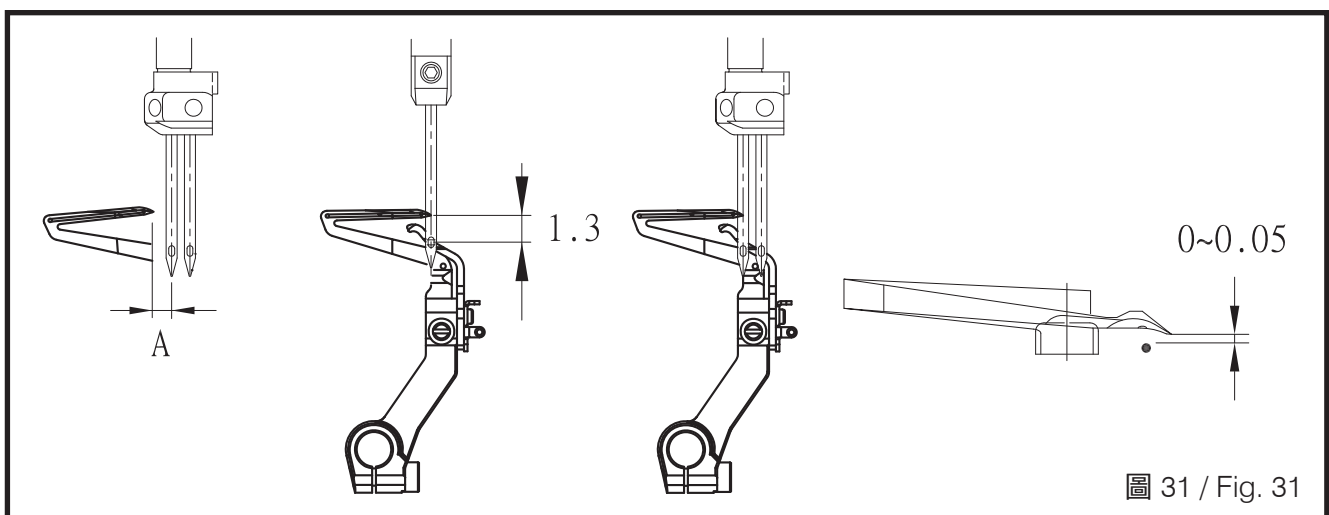
When the upper and the lower loopers meet, they reach each other as close as possible, but should not rub or hit each other. The clearance of point A is 0.5mm and the B point is 0.2mm. (Fig.32)



圖 32/ Fig. 32

4. 調整針與護針片之間隙

(1) 調整後護針片的方位

當下勾針尖移至針中心點時，後護針片①輕觸車針，兩者之間間隙為 0mm。調整方式為放鬆螺絲②移動後護針片①以調整之。

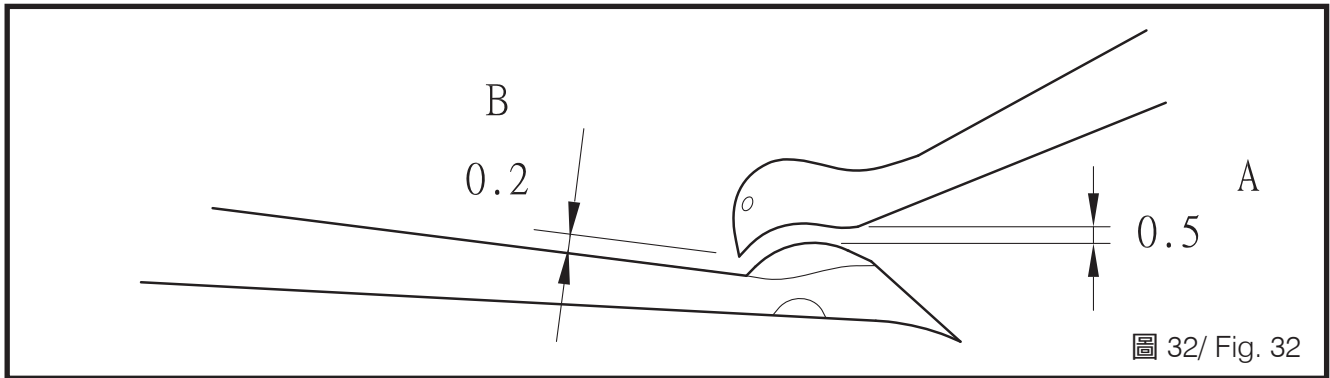
(圖 33)

(2) 調整前護針片的方位

當下勾針尖移針中心線時，前護針片③與針之間隙為 0.05mm ~ 0.10mm。調整方法為放鬆螺絲④，並移動前護針片③以調整之。(圖 33)

5. 針與護針片之關係

(1) 當下勾針由左向右至針中心時 (雙針以左針) 針與後護針片之間隙為 0~0.05mm。

(2) 當針在下死點時針與前護針片之間隙為 0.1~0.2mm。(圖 33)

4. Adjust the clearance between the needle and the needle guard.

(1) Adjust the rear needle guard

When the tip of the lower looper moves to the center of the needle, the rear needle guard touches the needle gently. The clearance between these two is 0mm. Adjusting manner is to loosen the screw ② and move the rear needle guard ① to adjust. (Fig.33)

(2) Adjust the front needle guard

When the tip of the lower looper moves to the center of the needle, the clearance between the front needle guard ③ and the needle is 0.05mm~0.10mm. Adjusting manner is to loosen the screw ④ and move the front needle guard ③ to adjust. (Fig.33)

5. Relation between the needle and the needle guard

(1) When the lower looper moves from left to right, to the center of the needle (The left needle is main while using double needles), the clearance between the needle and the needle guard is 0~0.05mm.

(2) When the needle is at the bottom dead point, the clearance between the needle and the needle guard is 0.1~0.2mm. (Fig.33)



圖 33 / Fig. 33

上送具高低行程調整

ADJUSTMENT OF THE HIGH-LOW STROKE OF THE UPPER FEED DOG

放鬆螺絲①，取下上蓋②，放鬆螺絲③，利用④滑動來調整高低行程。(圖 34)

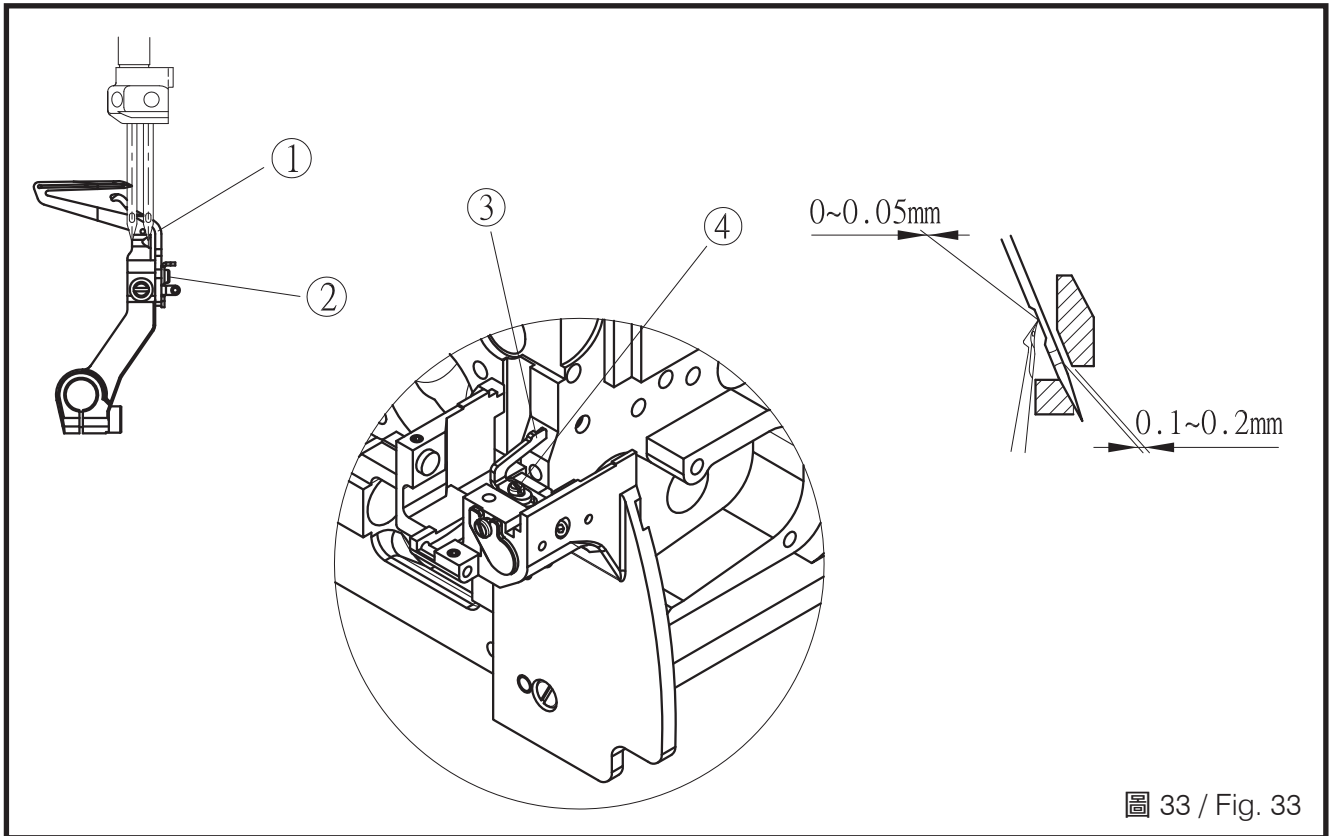
Loosen the screw ①, and take down the upper cover ②. Loosen the screw ③, and adjust the stroke by sliding ④. (Fig.34)



圖 34 / Fig.34

上送具與差動齒之關係

RELATION BETWEEN THE UPPER FEED DOG AND THE DIFFERENTIAL FEEDER

當上送具①走至行程最下方時，與差動齒②之距離為 0.5mm。(圖 35)

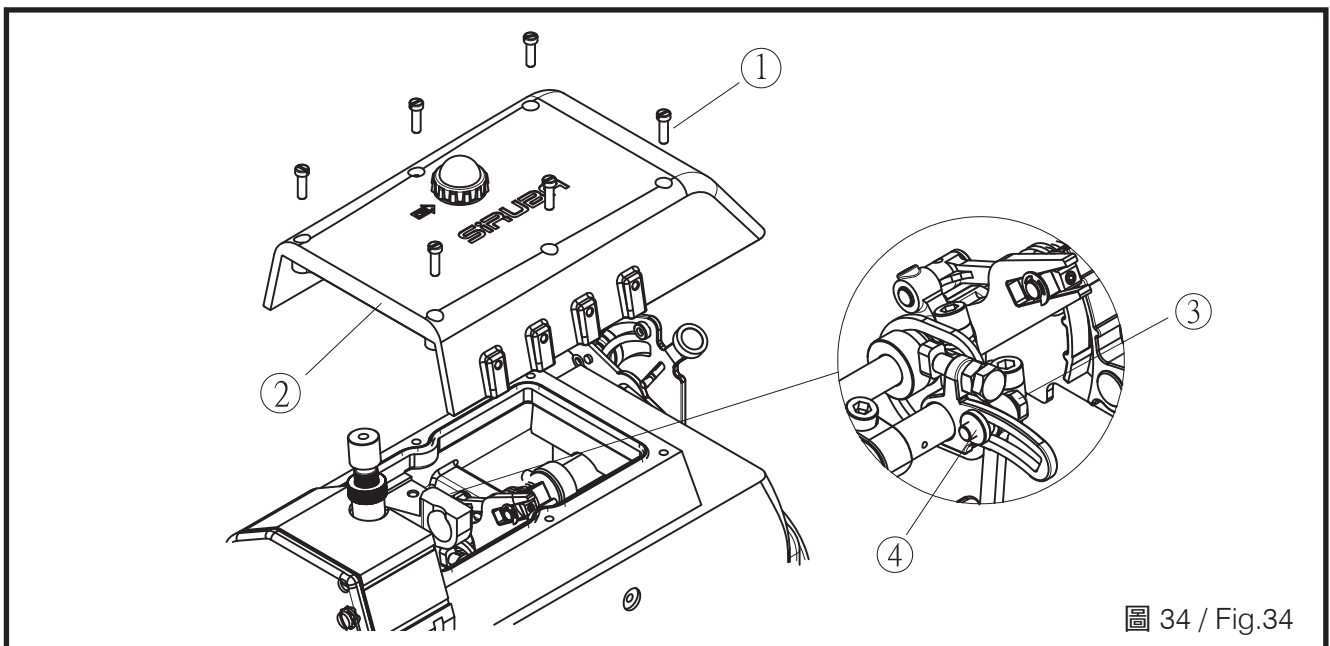
When the upper feeder ① moves to the lowest stroke, the distance from the differential feeder ② is 0.5mm. (Fig.35)



圖 35 / Fig. 35

上送具前後行程調整

ADJUST THE FRONT-REAR STROKE OF UPPER FEEDER

1. 旋鬆調整旋鈕①，往順時針方向行程越大，反之行程越小。(圖 36)

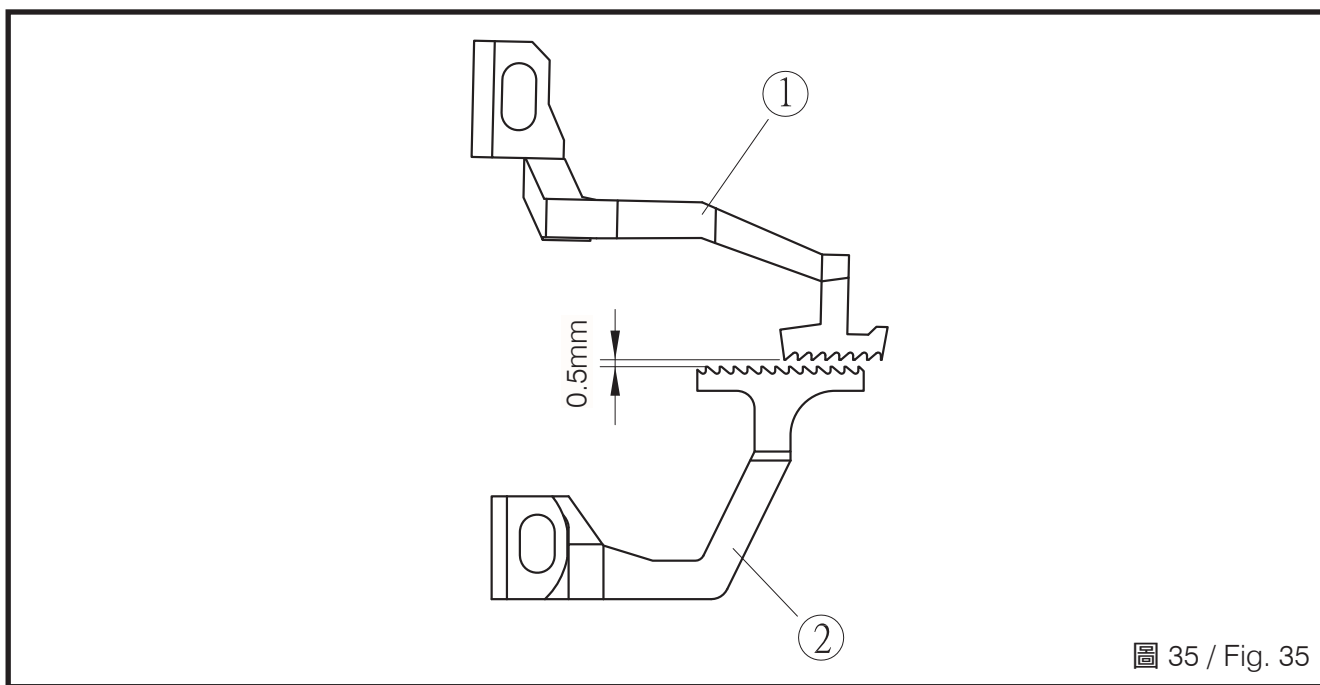
1. Loosen the adjusting knob ①, the stroke would be larger when turn the knob clockwise. The opposite way is to lower down the stroke. (Fig.36)



圖 36 / Fig. 36

2. 放鬆螺絲 ①，取下上蓋 ②，放鬆螺絲 ③ 來調整上送齒 ④ 前後距離。(圖 37)

2. Loosen the screw ①, and take down the upper cover ②. Loosen the screw ③ to adjust the front-rear of the upper feeder ④. (Fig.37)

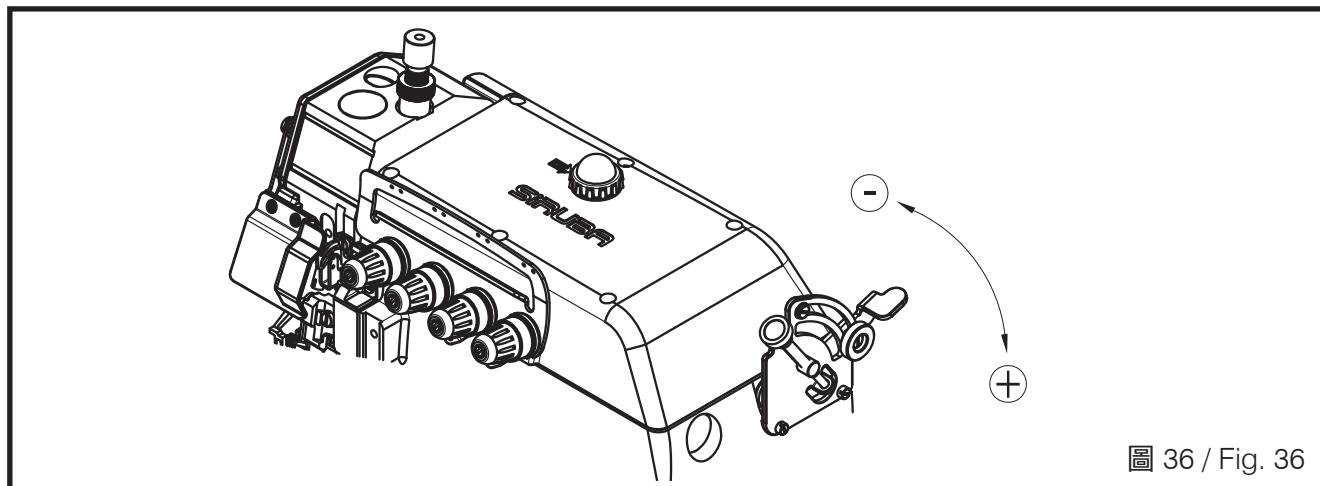
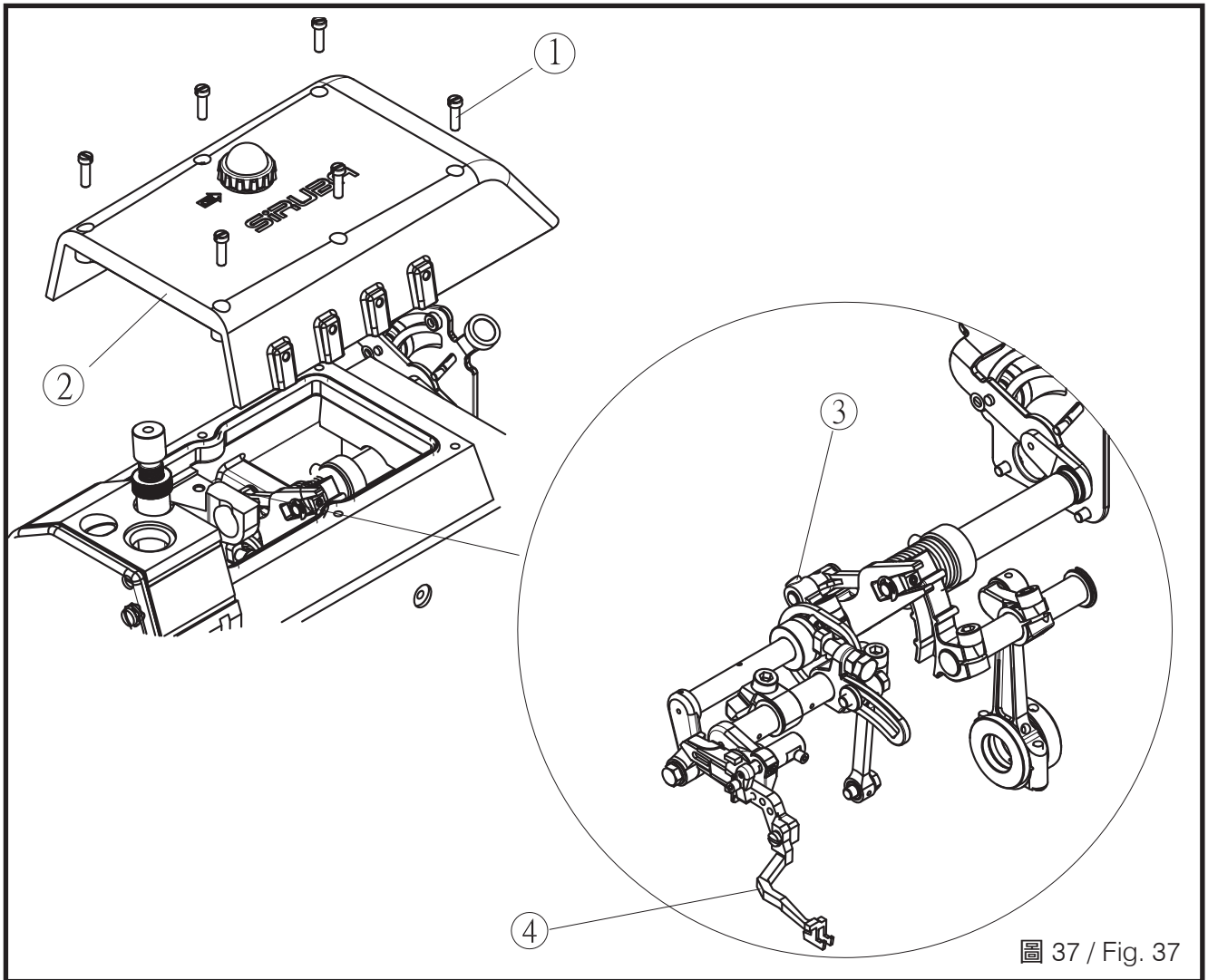

定位勾針線挑線凸輪

POSITION THE LOOPER AND TAKE-UP THREAD CAM



圖 38 / Fig. 38

針型式 Needle Type	504 505 514	504	514	504 514
勾針能力 Looper	S	H	H	SH
A	21.5	21.5	21.5	21.5
B	14.5	14.5	17.5	17.5
C	20	28	28	25
D	29	29	29	29
E	28	28	25	30
F	Left	Left	Left	Right
G	Left	Left	Left	Right

表 4 / Table4

操作環境照明

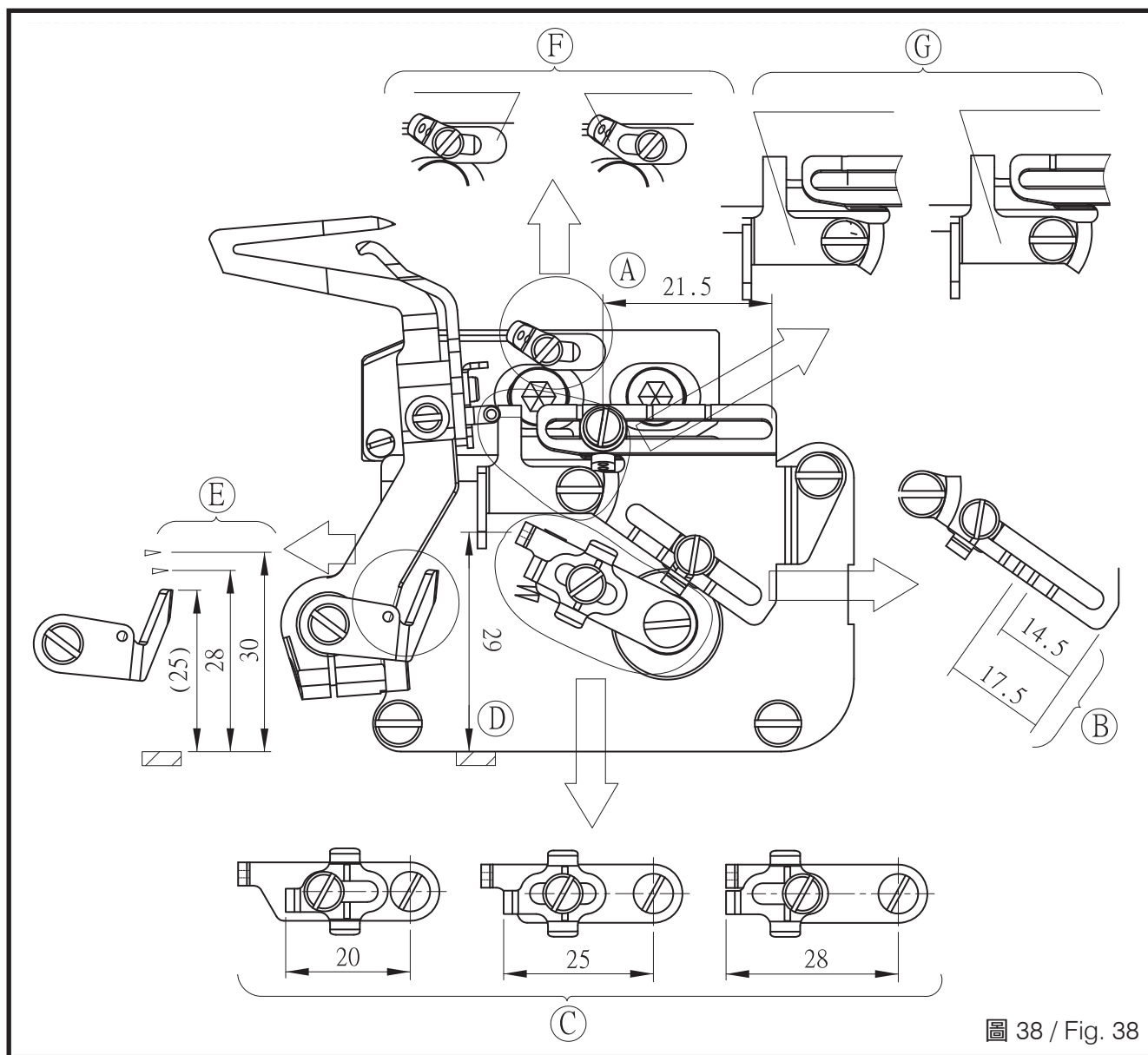
LIGHTENING OF THE
OPERATION ENVIRONMENT

提供一個警示標誌，告知使用者：工業用縫紉品或是縫紉系統必須在該縫紉區域未啟動照明裝置前，禁止插電或通電；照明裝置的最大輸入功率應該能夠輕易辨識，當照明裝置被重置或移動的時候，警示標誌也應設置在照明裝置插座上或是附近。警示標示如圖所示。

(圖 39)

Provide a warning that an industrial sewing unit or sewing system must always be unplugged from the local lighting of the sewing area before relamping, the marking of maximum rated input of lamp shall be easily discernible while the lamp is being replaced indicated on or near the lamp socket as shown on. (Fig.39)



圖 39 / Fig. 39

操作者條件

CONDITIONS OF ALL
OPERATORS

1. 熟讀並了解使用說明書內容。
2. 認識機器各部功能及注意事項。
3. 了解各警告標籤之意義。
4. 了解熟悉機器之操作方式。
5. 操作者須保持精神狀態良好。
6. 操作者須穿著合宜適當之工作服。
7. 視需要培養操作者使用機器之熟練度。

1. Read and understand well the content of this instruction book.
2. Know the functions of major parts and understand the notices
3. Truly realize the meanings of all warning tags
4. Realize and be familiar with how to operate this machine.
5. Operators have to keep well mental status.
6. Operators shall wear appropriate and proper working suits.
7. Develop the familiarity of how to operate the machine if needed.



注意CAUTION



清潔作業前，請切斷電源。當誤觸啓動開關時，縫紉機動作易導致人員受傷。
Turn off the power switch before carrying out cleaning. The machine may operate if the treadle is pressed incautiously, which could result in injury.



加潤滑油和黃油時，務必戴好保護眼鏡和手套，以防潤滑油進入眼中或沾在皮膚上，易引起發炎。
Be sure to wear protective goggles and gloves when handling the lubricating oil and grease so that they do not get into your eyes or onto your skin, otherwise inflammation can be resulted.



潤滑油或黃油不能飲用，否則將會引起嘔吐和腹瀉，將油放在小孩拿不到的地方。
Furthermore, do not drink or eat the oil nor the grease for they can cause vomiting and diarrhea. Keep the oil away of the reach of children.

縫紉機頭倒下或豎起時，請以雙手進行操作。
Use both hands to hold the machine head when tilting or returning it to its original position.



單手操作時，因縫紉機的重量較重，萬一滑落易導致受傷。
If only using one hand to move the machine, the weight of the machine head may cause slipping and you may get hurt.

定期保養項目(表 5)

Periodical Maintenance Items(Table5)

保養循環 Maintenance Cycle	保養項目 Maintenance Items
每天 Daily	1. 清潔送料具上之棉絮 1. Clean the lint on the feed dog.
	2. 檢查油盤是否有足夠之液態油。(油量在油鏡之上、下兩紅漆記號間) 2. Check if there has enough liquid oil inside the oil pan. (The amount should be between the red up and down paint mark of the oil level gauge.)
	3. 保持機器及操作台清潔 3. Keep the machine and the operation table clean.
	4. 清潔手輪濾網上之棉絮 4. Clean the fiber on the filter net of the hand wheel.
每週 Weekly	1. 保持電源外觀乾淨 1. Keep the power cords looking clean and neat.
	2. 保持操作面板乾淨 2. Keep the operational panel clean
	3. 檢查電源零件是否鬆脫或在正確位置 3. Check if the power parts is loosening or still at the right position
每三個月 Quarterly	1. 更換油盤內之液態油 1. Change the liquid oil inside the oil pan

表 5 / Table5

報廢流程

DEMOLITION PROCEDURE

1. 當機器需要被淘汰與報廢時，有一些基本規則必須採納、遵守以保護環境及公眾健康。
2. 所有的機器零組件必須依照下列分類來區分開：
 - (1) 所有護套、可伸縮軟管及塑膠或非金屬零件。
 - (2) 電器零件：開關、照明器具等。
 - (3) 絕緣材料：石棉、彈性／可伸縮橡膠片。
 - (4) 金屬：含鐵金屬、銅、青銅與黃銅、其他各種金屬。
3. 以此方法，所有材質可以正確的淘汰，回收再利用或鎔解為可再使用或再處理而不至於危害環境。

1. When the machine needs to be eliminated and demolished, certain basic rules must be observed to protect the environment and public health.
2. All machine components must be divided according to categories as the followings:
 - (1) All sheathes, flexible hosing and plastic or non-metal components.
 - (2) Electricity components: switches, or lighting components.
 - (3) Insulation materials: rock wool, and flexible rubber strips.
 - (4) Metals: ferrous metals, copper, bronze and brass, various.
3. In this way, all materials can be eliminated correctly, recycled, or melted down for reuse or disposed of so that they do not harm the environment.

SIRUBA TABLE CUT - OUT	Series	Item Code	Subclass Remark	Mounting
	700KS/T	700KS-T	UNIT: mm TOLERANCE: ± 2 WEIGHT: 11.6 kg $\pm 5\%$	Semi-submerged
				Date
				2014/06/18

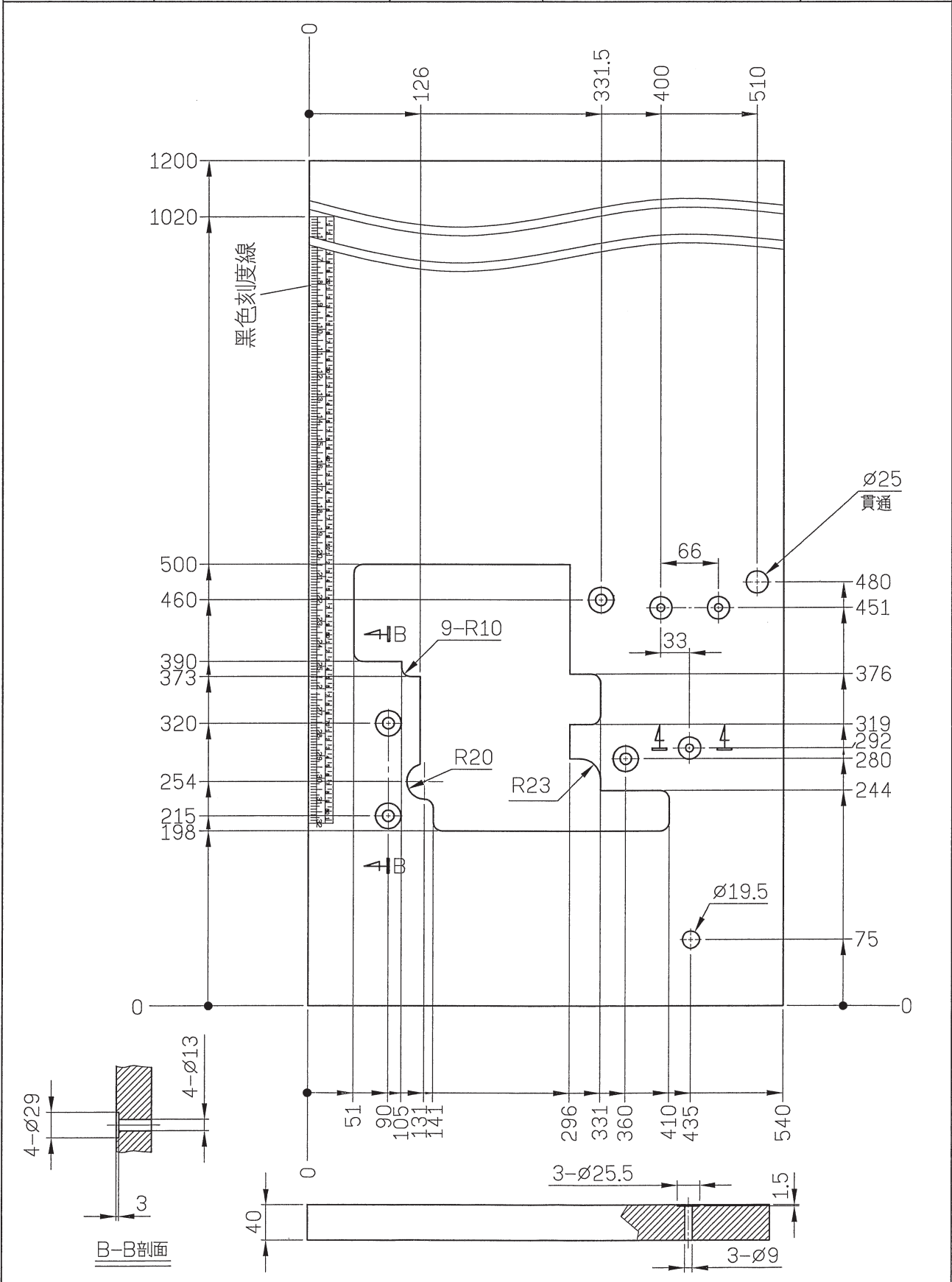

SIRUBA TABLE CUT - OUT	Series	Item Code	Subclass Remark	Mounting
	700KS/T	700KS-T1	UNIT: mm TOLERANCE: ±2 WEIGHT: 11.6 kg ±5%	Semi-submerged
				Date
				2013/09/30

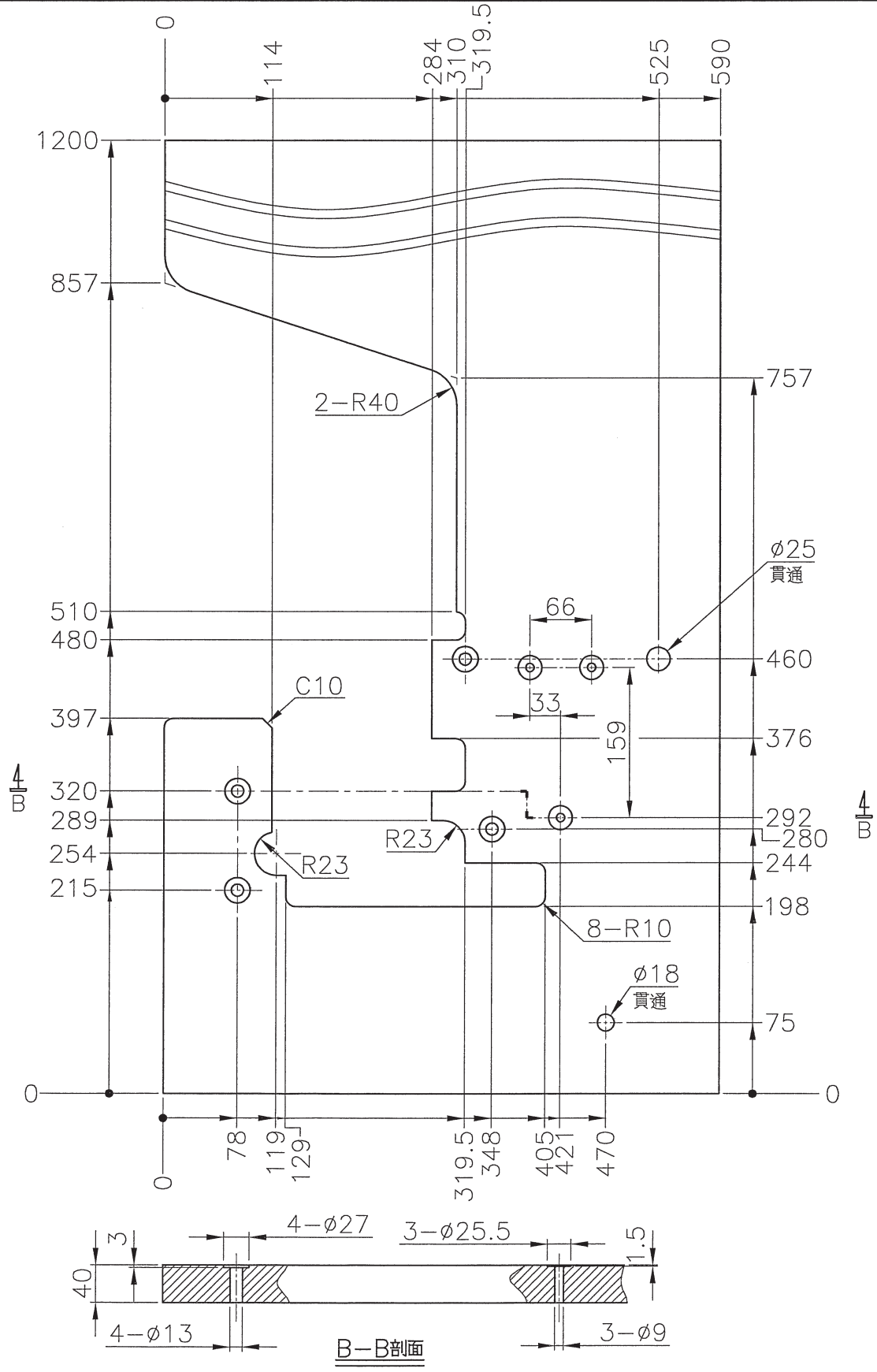

SIRUBA TABLE CUT - OUT	Series	Item Code	Subclass Remark	Mounting
	700KS/T	700KS-T2	UNIT: mm TOLERANCE: ± 2 WEIGHT: 11.6 kg $\pm 5\%$	Semi-submerged installation
				Date 2014/06/18

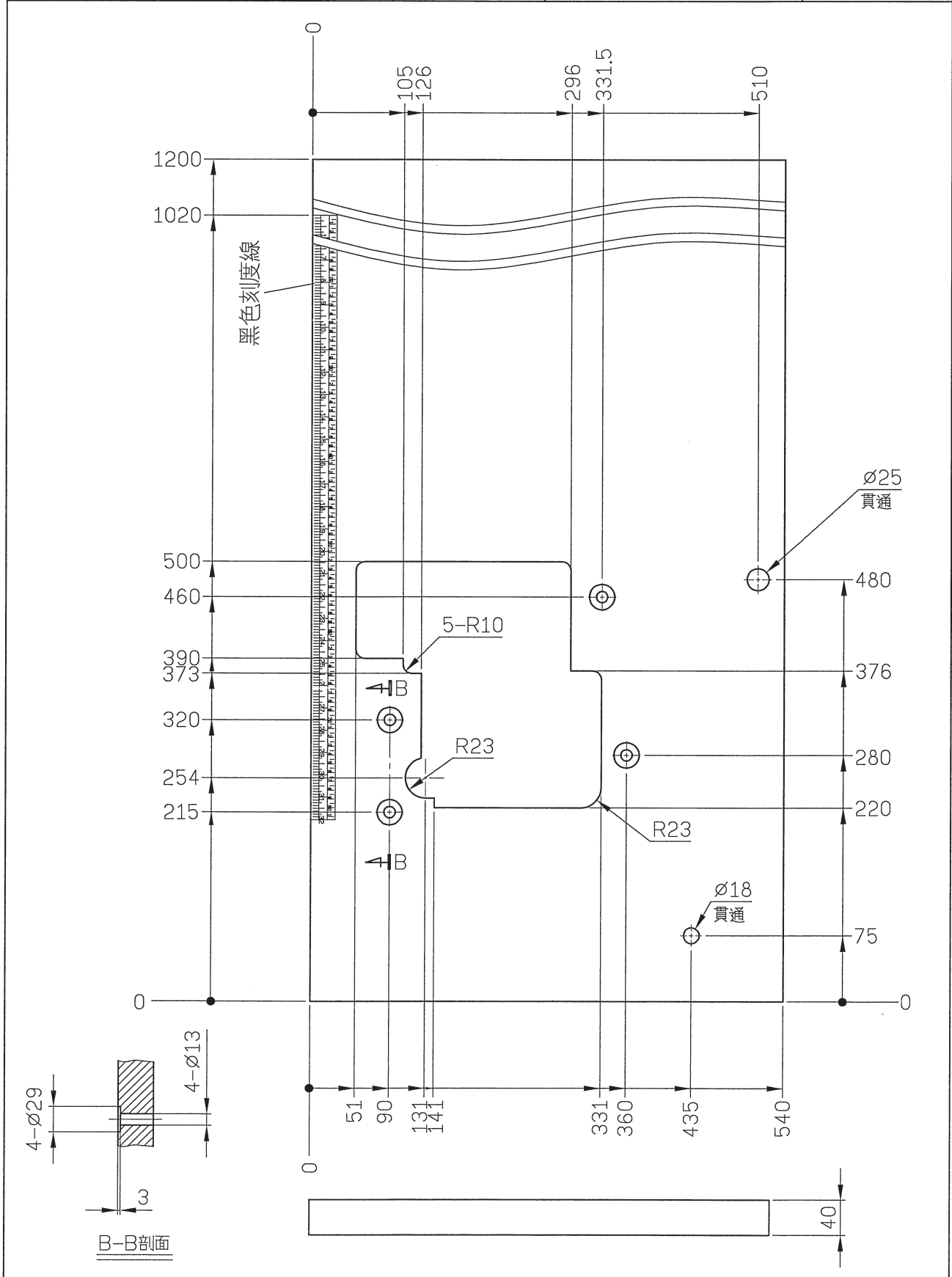

SIRUBA TABLE CUT - OUT	Series	Item Code	Subclass Remark	Mounting
	700KS/T	700KS-T3	UNIT: mm TOLERANCE: ±2 WEIGHT: 11.6 kg ±5%	Semi-submerged installation
				Date
				2014/06/05

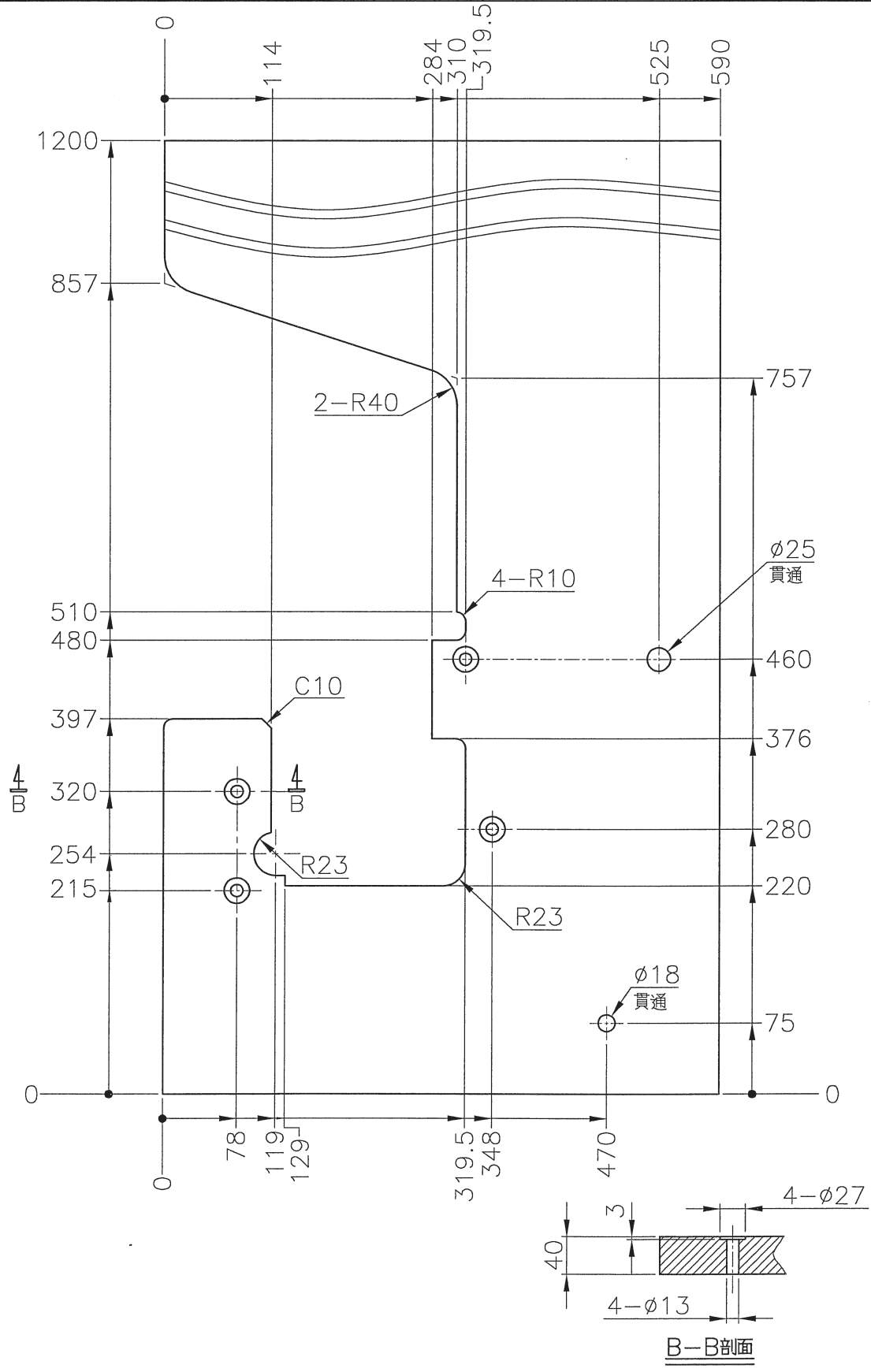

SIRUBATABLE
CUT - OUT

Series

700KS/T

Item Code

700KS-T4

Subclass Remark

UNIT: mm
TOLERANCE: ± 2
WEIGHT: 11.6 kg $\pm 5\%$

Mounting

Semi-submerged
installation

Date

2016/08/08

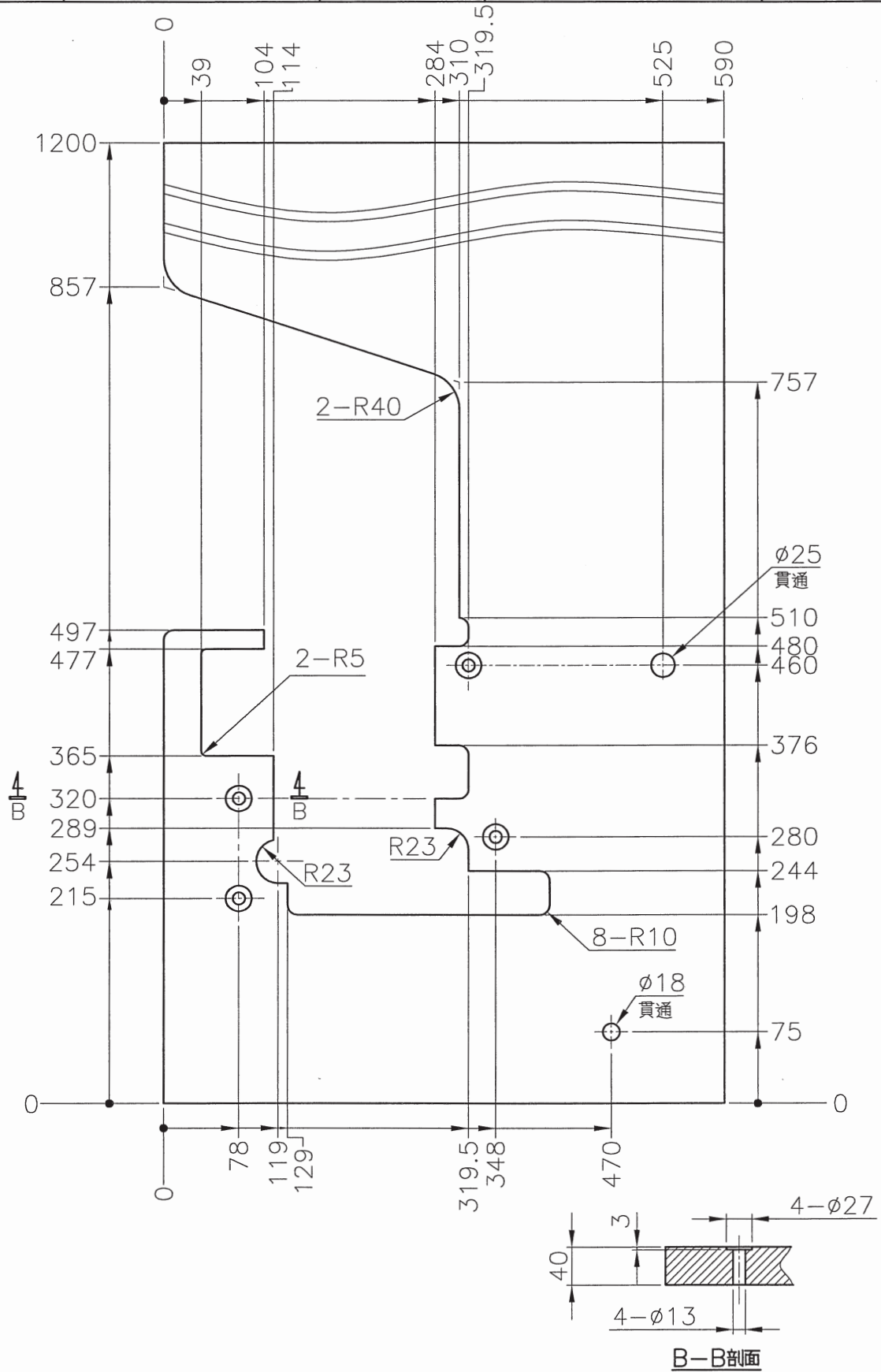

SIRUBA GAGE PARTS LIST		Series 700KST										Remark		Page 1 / 1	Date 2018/10/12
機型 Model	針板 Needle Plate	送具 Feed Dog	送具 Feed Dog	送具 Feed Dog	押具 Presser Foot	上送具 TopFeed Dog	衝程 Crank	大心 Crank Shaft	針腳 Needle Clamp	勾針迴轉座 Upper Looper Holder	上勾針 Upper Looper	下勾針 Lower Looper			
737KST	504M-3-03	E503	D515	D516	H515	P552-A	D551	KJ516-E	KD501	KG231K-E	KJ508	LP526	KL502A	DCX27#11	
	504M-3-04	E504	D515	D516	H515	P555-A	D551	KJ516-E	KD501	KG231K-E	KJ508	LP526	KL502A	DCX27#11	
	504M-3-05	E505	D515	D516	H515	P554-A	D551	KJ516-E	KD501	KG231K-E	KJ508	LP526	KL502A	DCX27#11	
	504H-3-03	E513	D515A	D117K	H517	P552-A	D551	KJ513-E	KD501B	KG231K-E	KJ528	LP519	KL502A	DCX27#11	
	504H-3-04	E324K	D515A	D117K	H517	P555-A	D551	KJ513-E	KD501B	KG231K-E	KJ528	LP519	KL502A	DCX27#11	
	504H-3-05	E515	D515A	D117K	H517	P554-A	D551	KJ513-E	KD501B	KG231K-E	KJ528	LP519	KL502A	DCX27#11	
	514M-3-23	E523	D515	D516	H515	P553-A	D551	KJ513-E	KD501	KG242K-E	KJ508	LP518	KL502	DCX27#11*2	
	514M-3-24	E424	D515	D516	H515	P550-A	D551	KJ513-E	KD501	KG242K-E	KJ508	LP518	KL502	DCX27#11*2	
	514M-3-24/VT	E424	D515	D516	H515	P550-A	D551	KJ513-E	KD501	KG242K-E	KJ508	LP518	KL502	DCX27#11*2	
	514M-3-24/VT/RSK	E424	D515	D516	H515	P550-A	D551	KJ513-E	KD501	KG242K-E	KJ508	LP518	KL502	DCX27#11*2	
747KST	514M-3-25	E525	D515	D516	H515	P551-A	D551	KJ513-E	KD501	KG242K-E	KJ508	LP518	KL502	DCX27#11*2	
	514H-3-23	E533	D515A	D117K	H517	P553-A	D551	KJ513-E	KD501B	KG242K-E	KJ528	LP519	KL502A	DCX27#11*2	
	514H-3-24	E434K	D515A	D117K	H517	P550-A	D551	KJ513-E	KD501B	KG242K-E	KJ528	LP519	KL502A	DCX27#11*2	
	514H-3-25	E535	D515A	D117K	H517	P551-A	D551	KJ513-E	KD501B	KG242K-E	KJ528	LP519	KL502A	DCX27#11*2	

SIRUBA PARTS LIST	Series	Parts Group	Subclass / Remark	Page
	700KST	KA		1/1
				Date
				2017/2/9

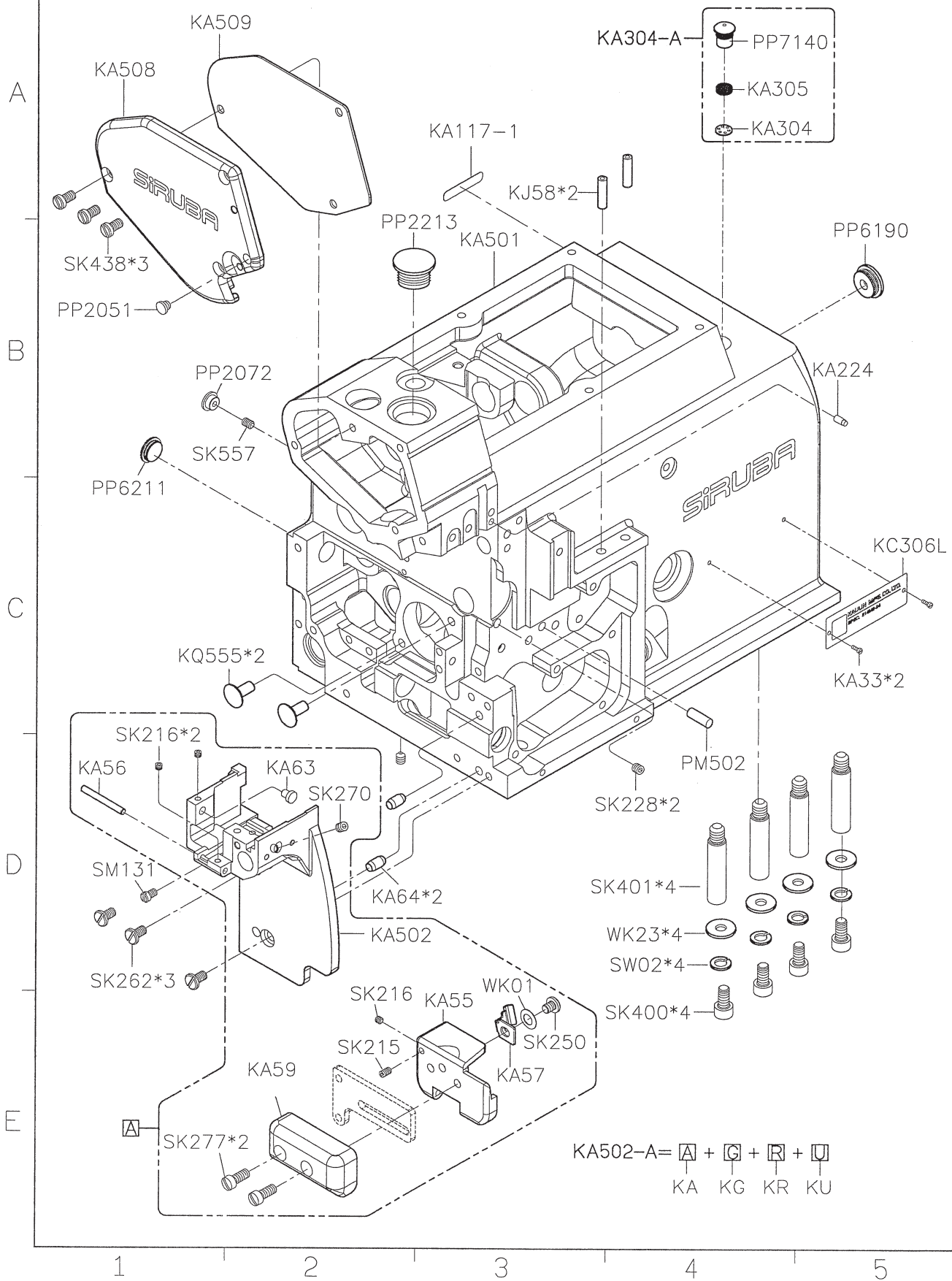

SIRUBA PARTS LIST	Series	Parts Group	Subclass / Remark	Page
	700KST	KB		1/1
				Date
				2018/07/05

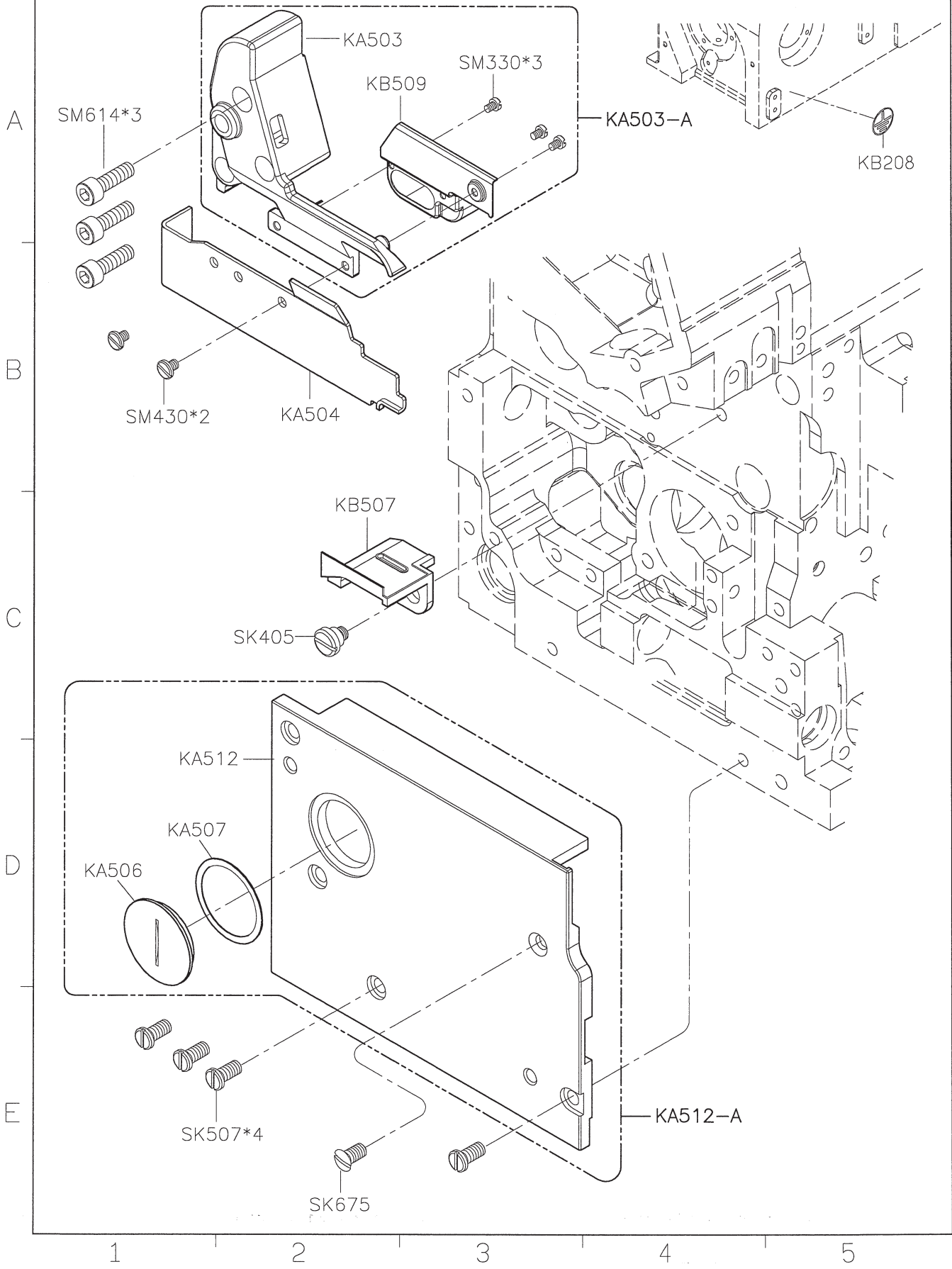

SIRUBA PARTS LIST	Series	Parts Group	Subclass / Remark	Page
	700KST	KC		1/1
				Date
				2022/12/01

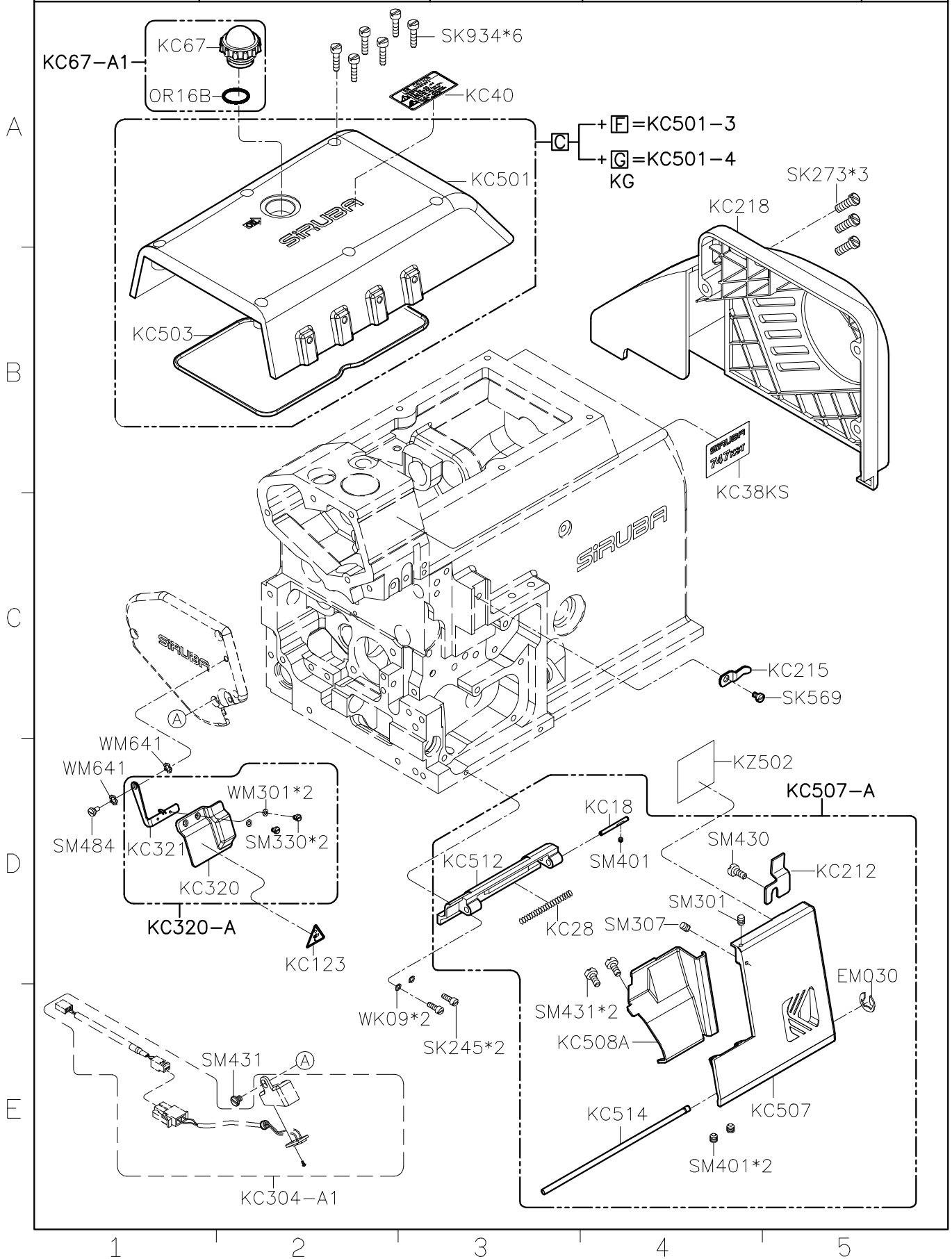

SIRUBA PARTS LIST	Series	Parts Group	Subclass / Remark	Page
	700KST	KD		1/1
				Date
				2017/2/14

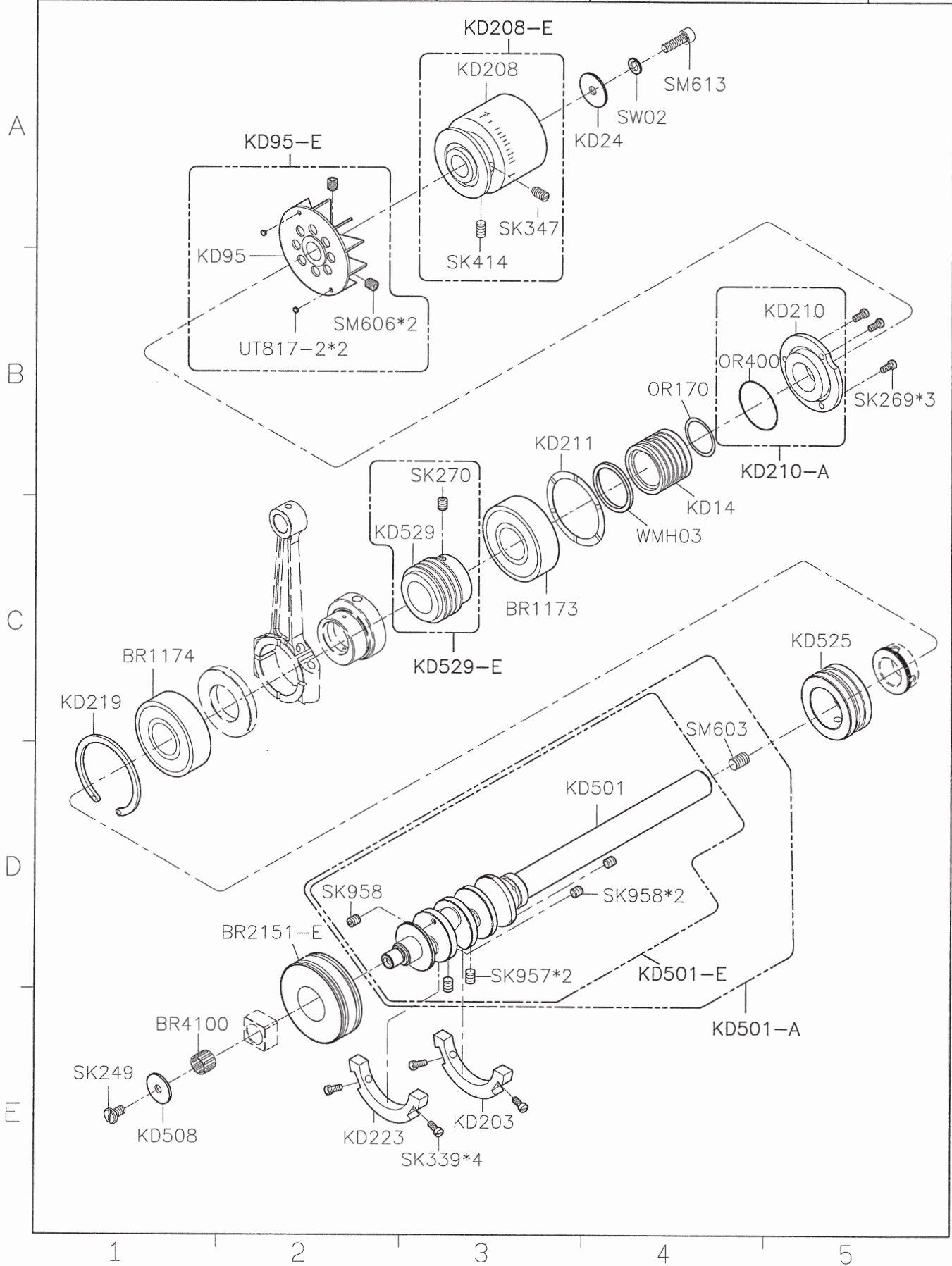

SIRUBA PARTS LIST	Series	Parts Group	Subclass / Remark	Page
	700KST	KF		1/1
				Date
				2022/09/14

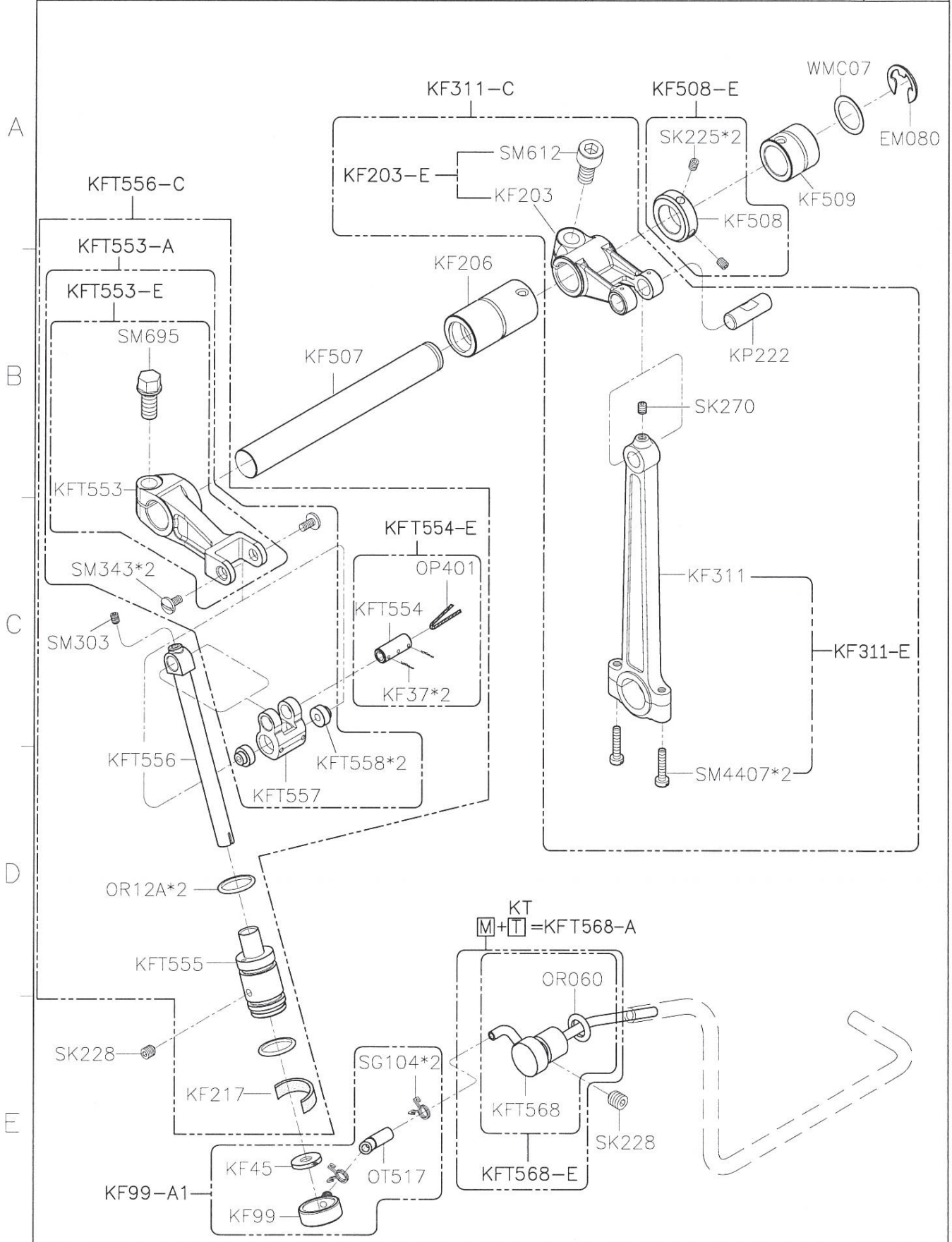

SIRUBA PARTS LIST	Series	Parts Group	Subclass / Remark	Page
	700KST	KG		1/1
				Date
				2019/04/19

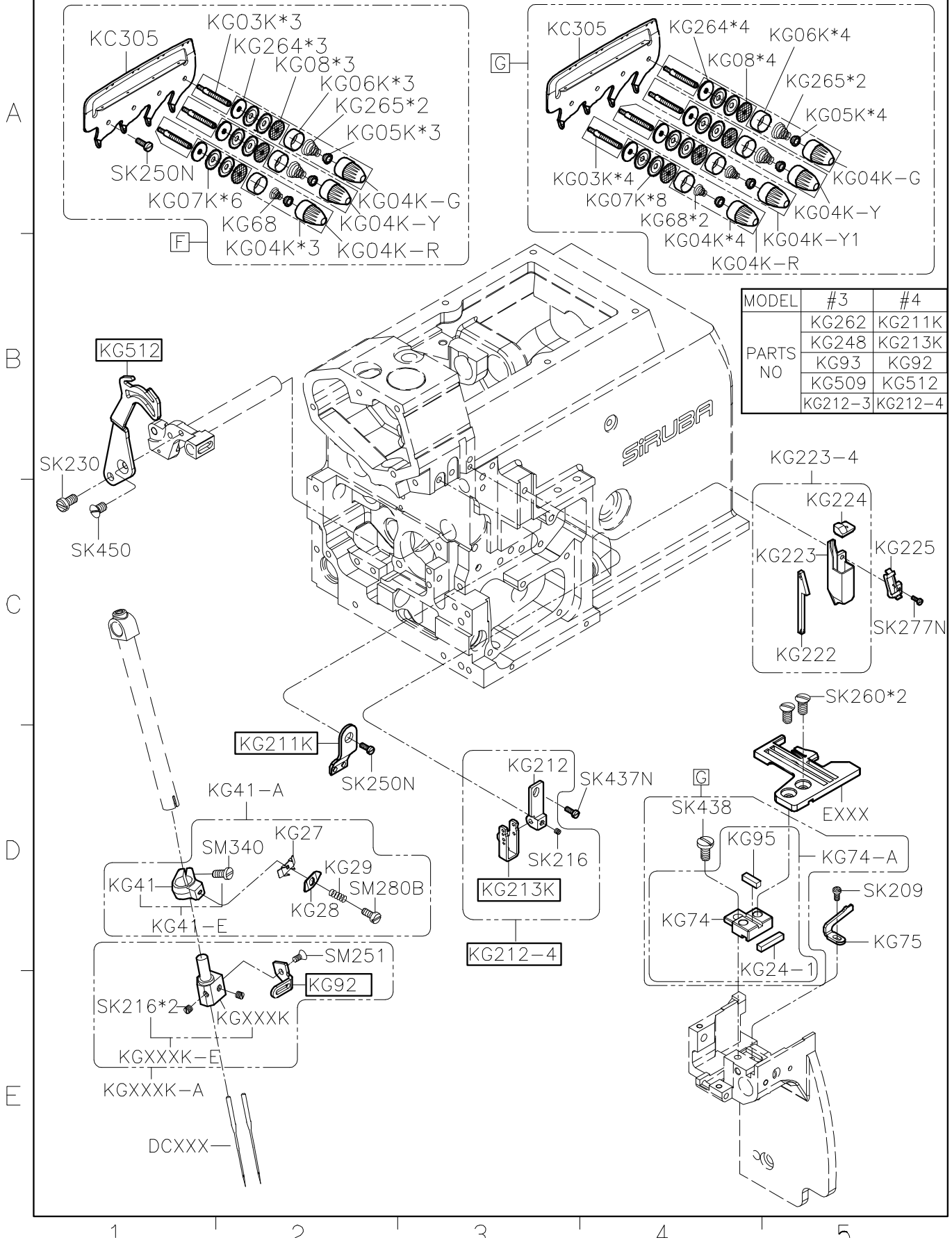

SIRUBA PARTS LIST	Series	Parts Group	Subclass / Remark	Page
	700KST	KJ		1/1
				Date
				2016/12/28

MODEL	#3	#4
PARTS NO	KJ516	KJ513
	KJ516-E	KJ513-E
	KJ516-C	KJ513-C

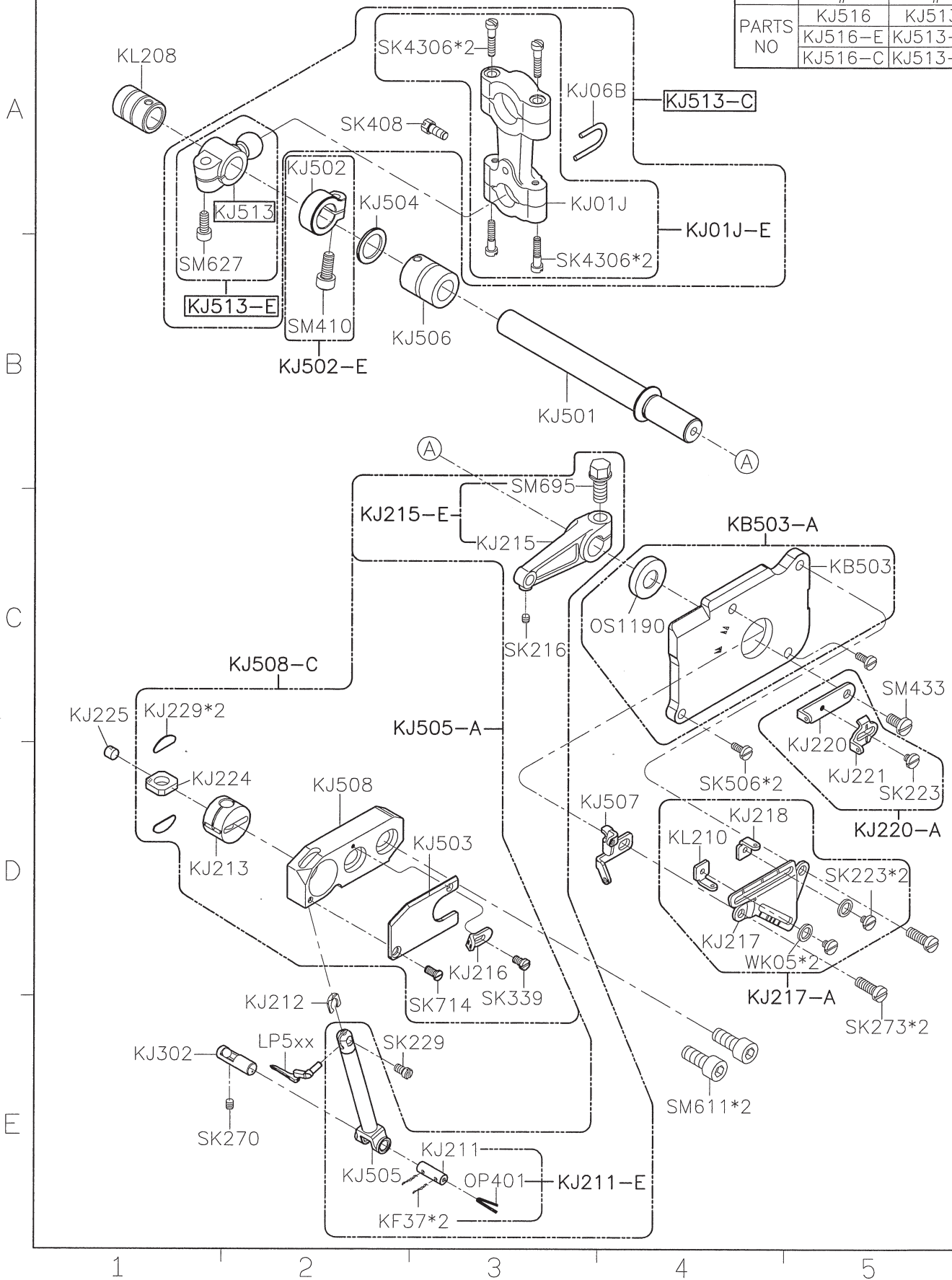

MODEL	#3	#4
PARTS NO	KL502A KL514-A1	KL502 KL514-A

A

B

C

D

E

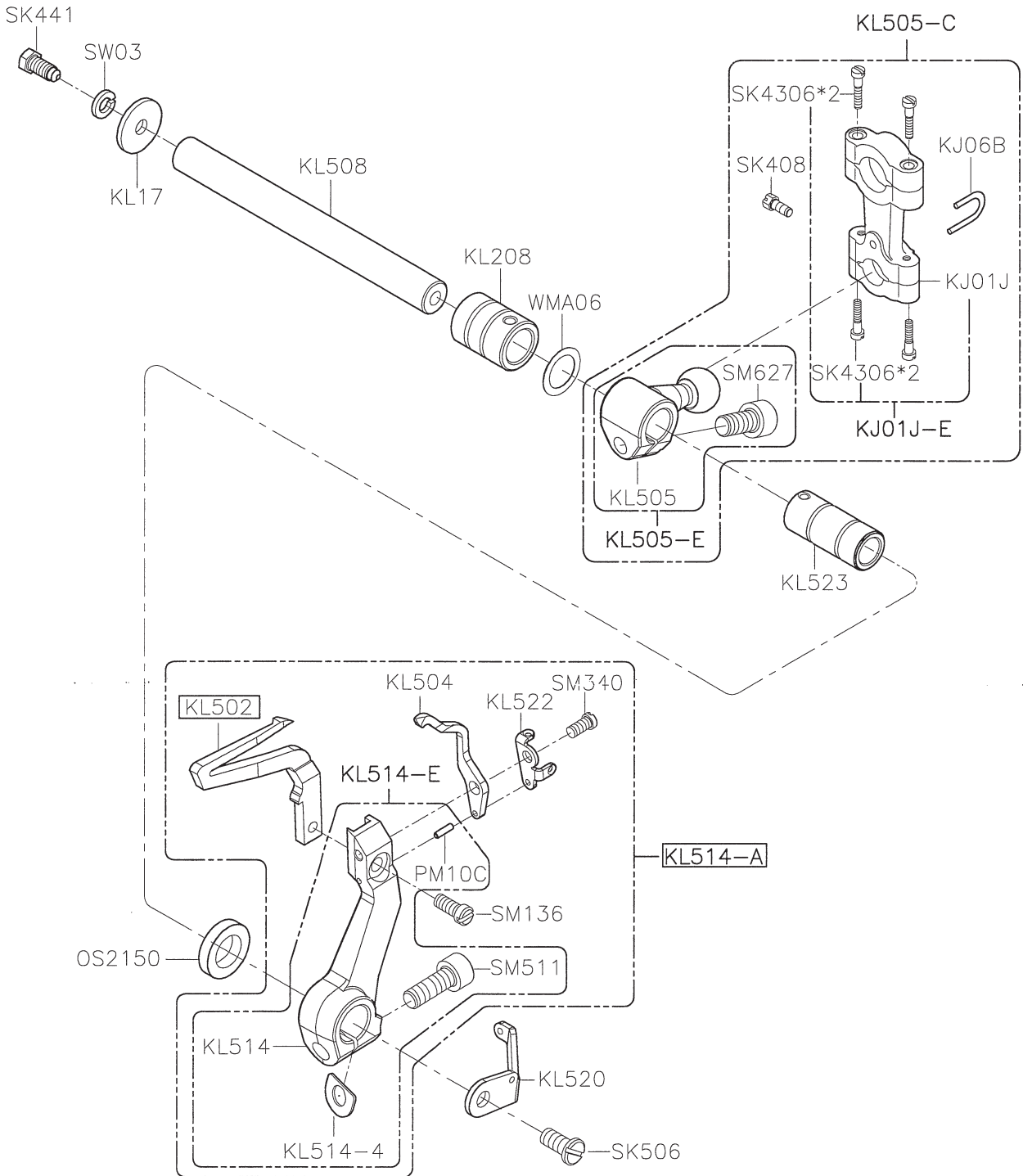

1

2

3

4

5

SIRUBA PARTS LIST	Series	Parts Group	Subclass / Remark	Page
	700KST	KP		1/1
				Date
				2017/2/2

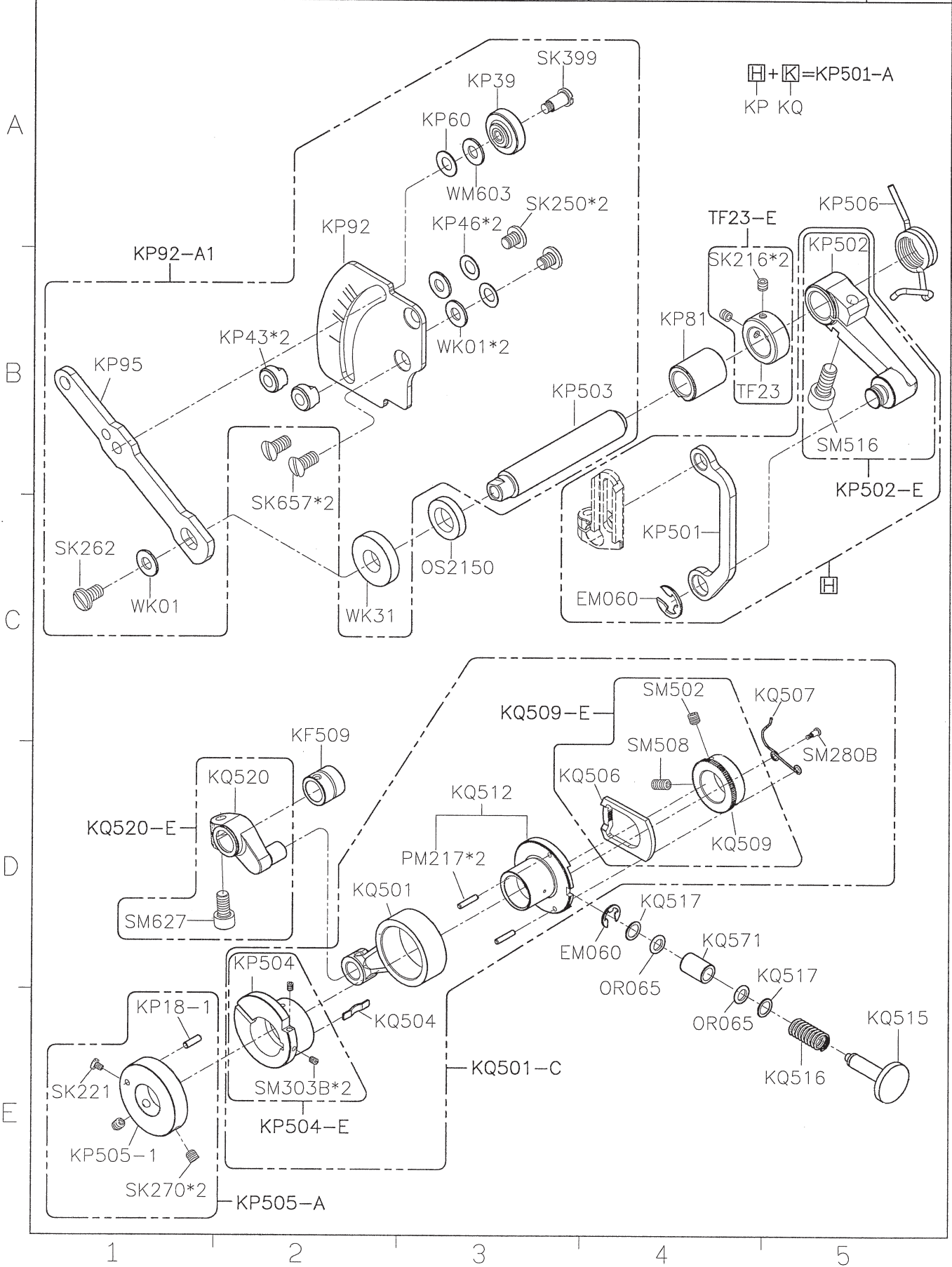

SIRUBA PARTS LIST	Series	Parts Group	Subclass / Remark	Page
	700KST	KQ		1/1
				Date
				2018/8/2

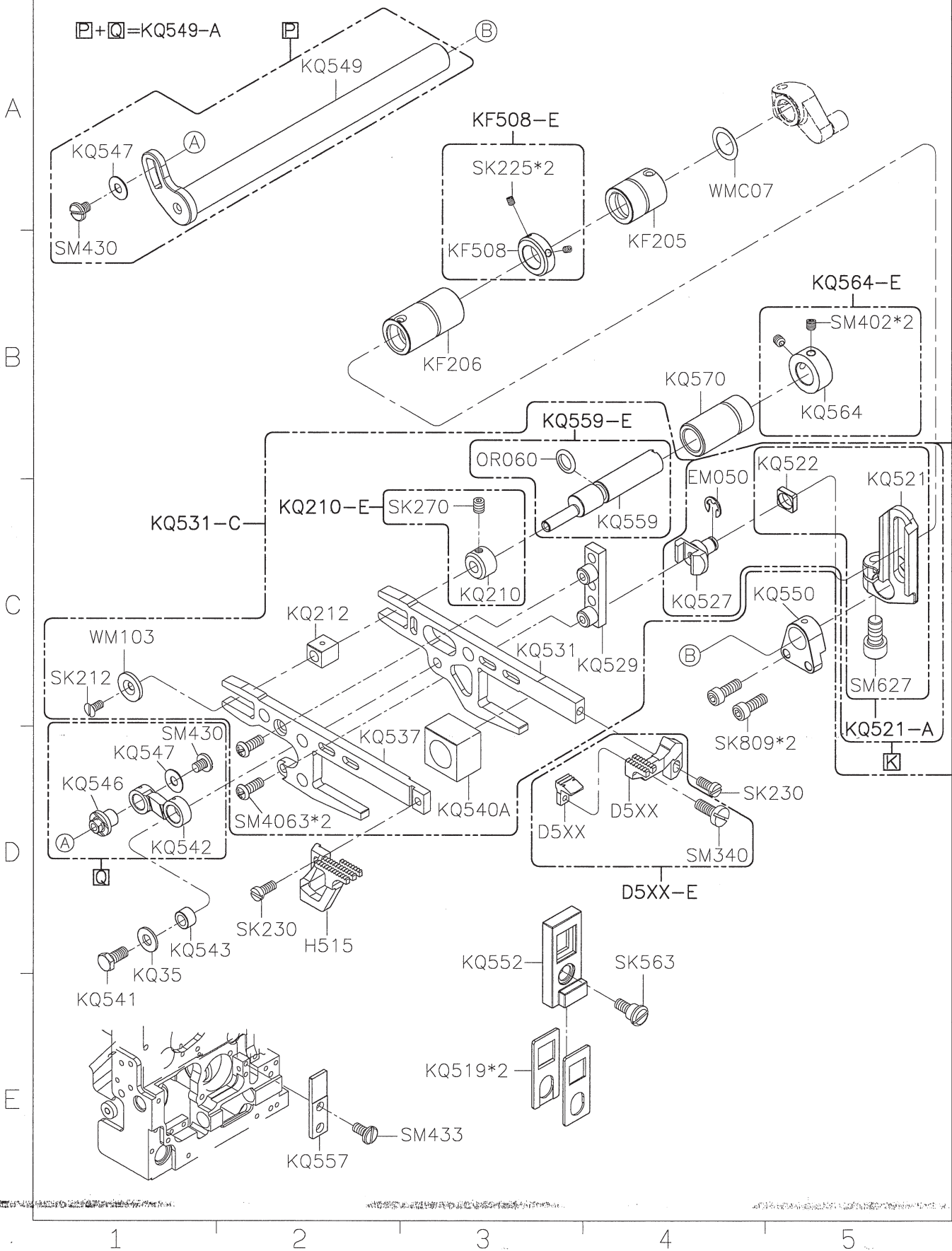

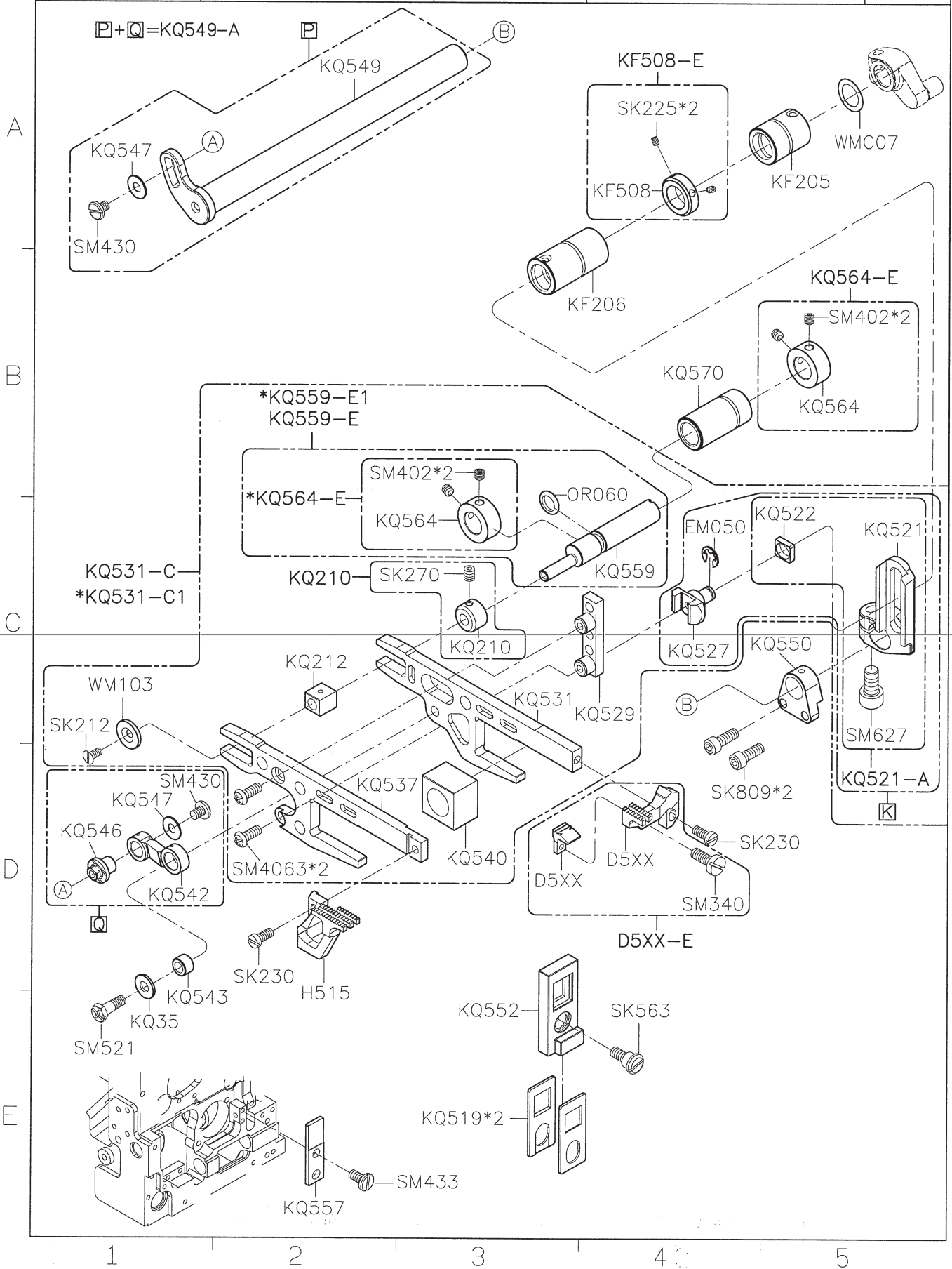

SIRUBA PARTS LIST	Series	Parts Group	Subclass / Remark	Page
	700KST	KR		1/1
				Date
				2017/9/27

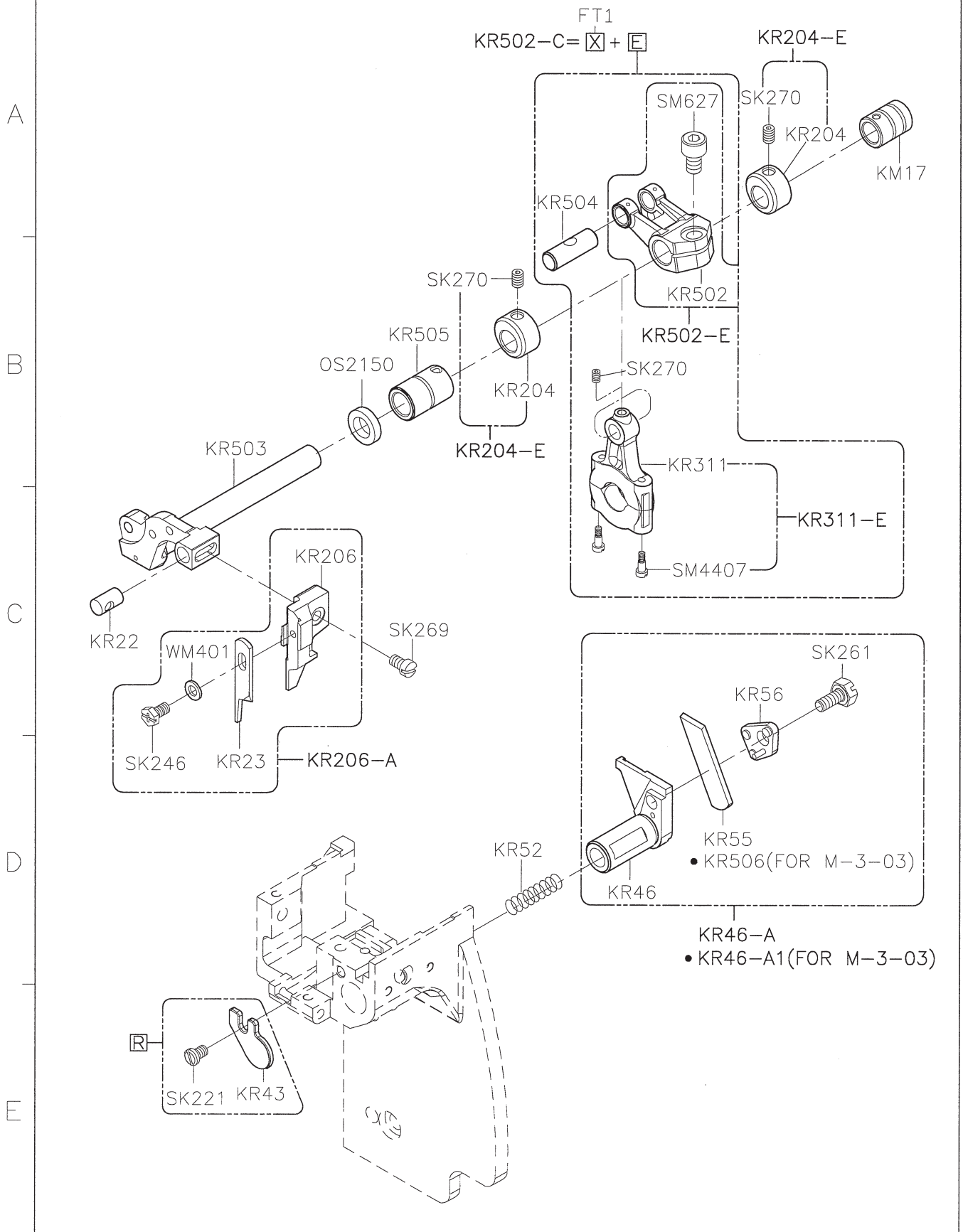

1 2 3 4 5

SIRUBA

PARTS LIST

Series

700KST

Parts Group

KS

Subclass / Remark

Page

1/1

Date

2020/11/25

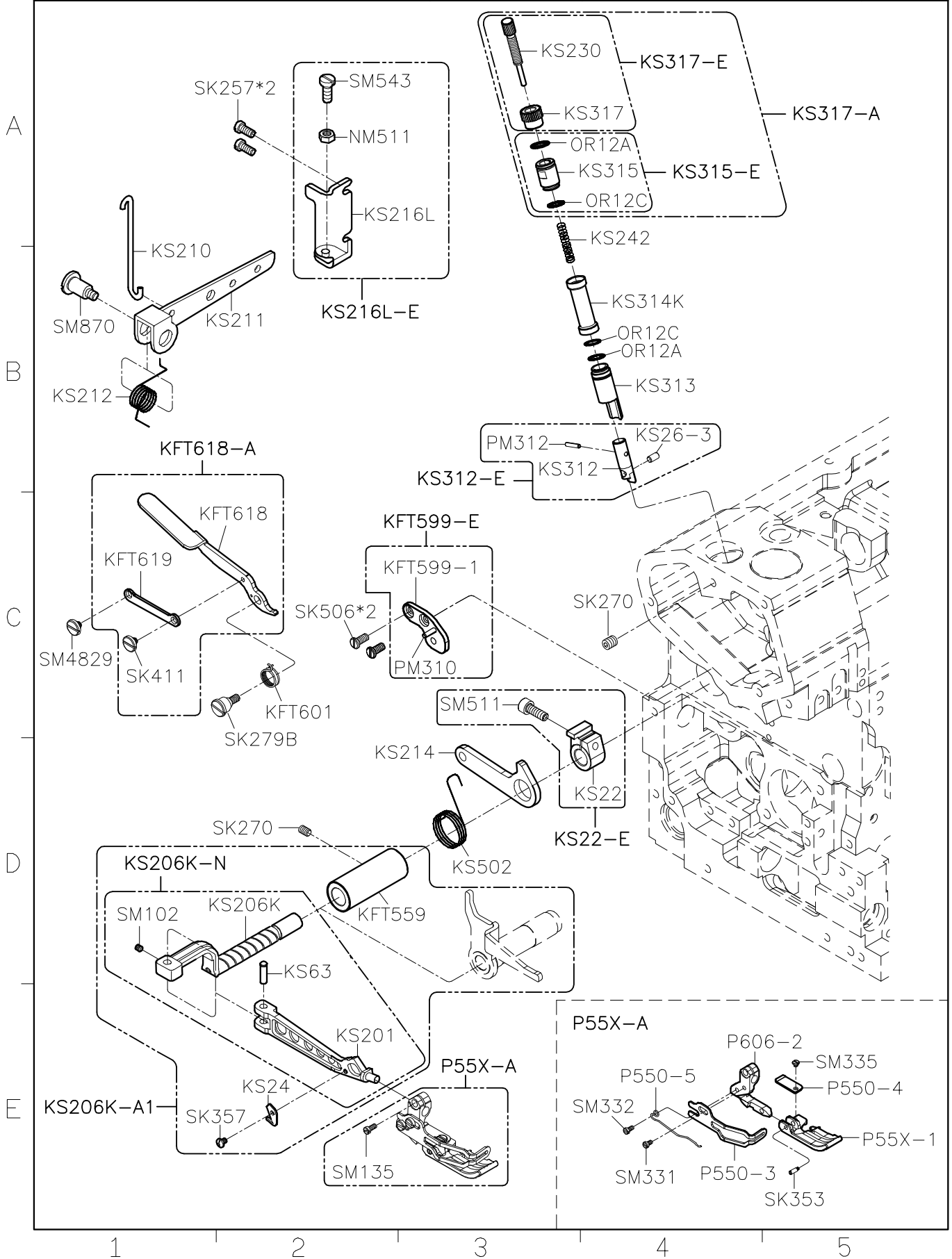

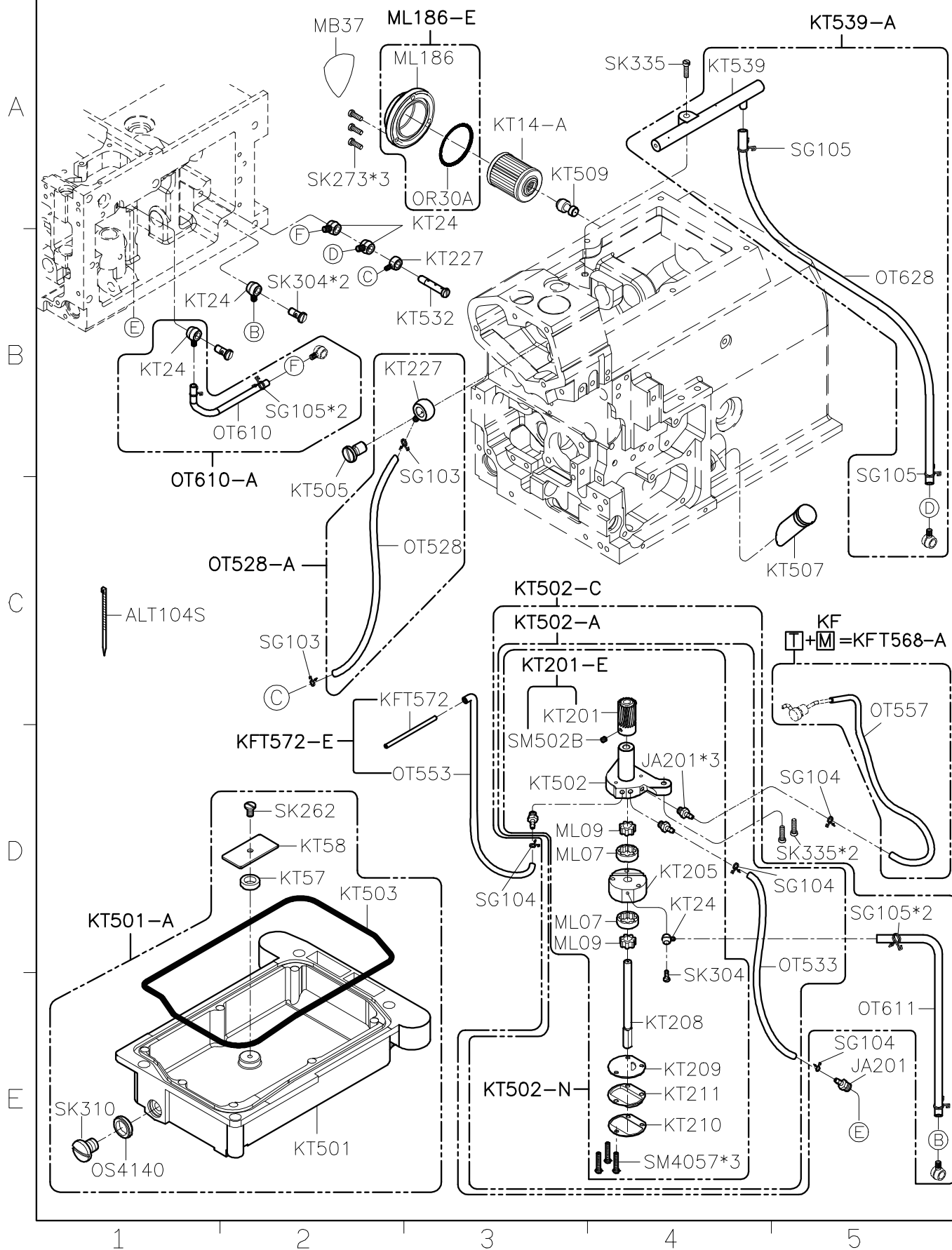

SIRUBA PARTS LIST	Series	Parts Group	Subclass / Remark	Page
	700KS/T	KU		1/1
				Date
				2013/10/09

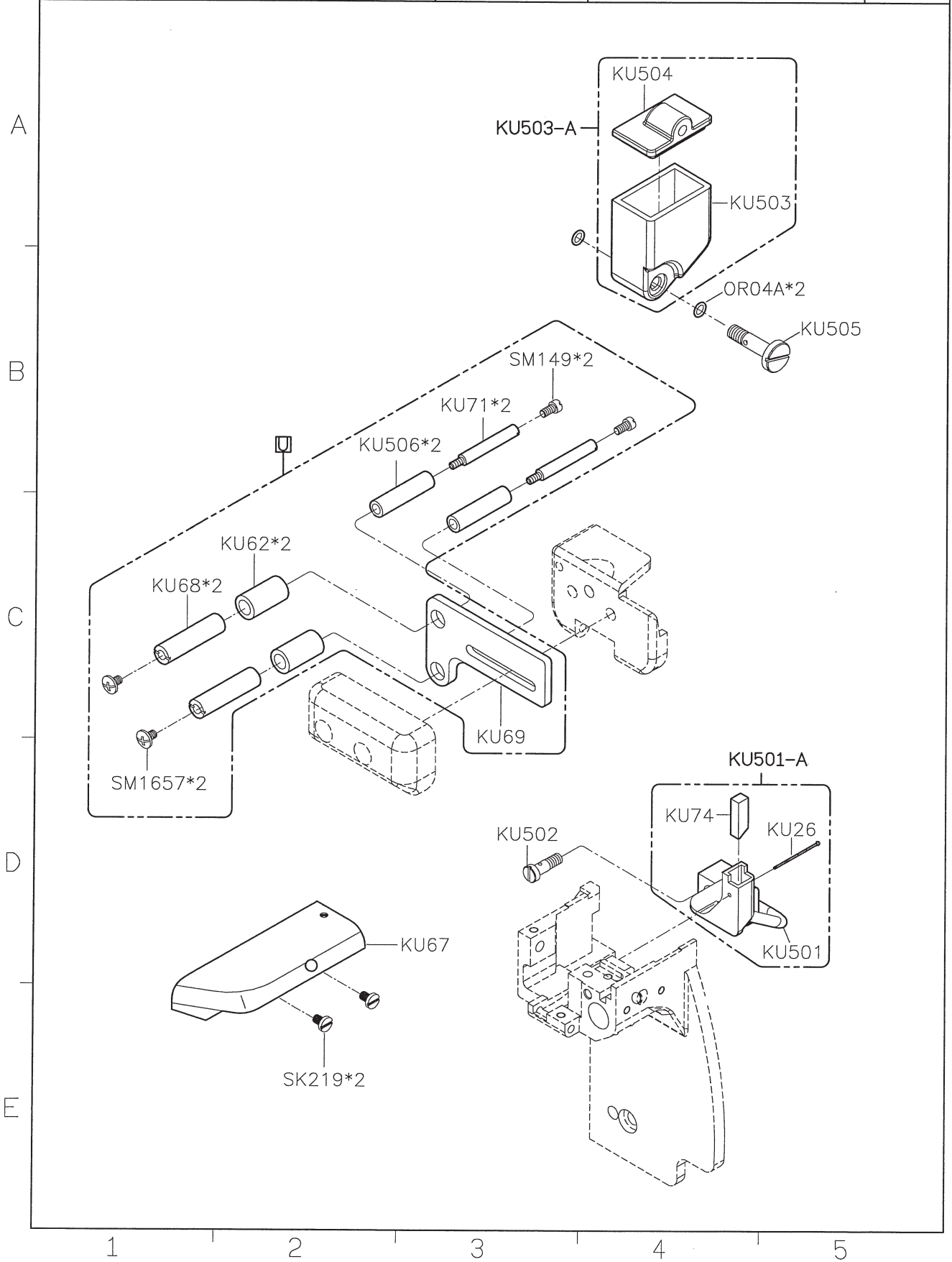

SIRUBA PARTS LIST	Series	Parts Group	Subclass / Remark	Page
	拷克	KW		1/4
	Overlock			Date
	含MO6800系列			2022/07/11

KW40E-3

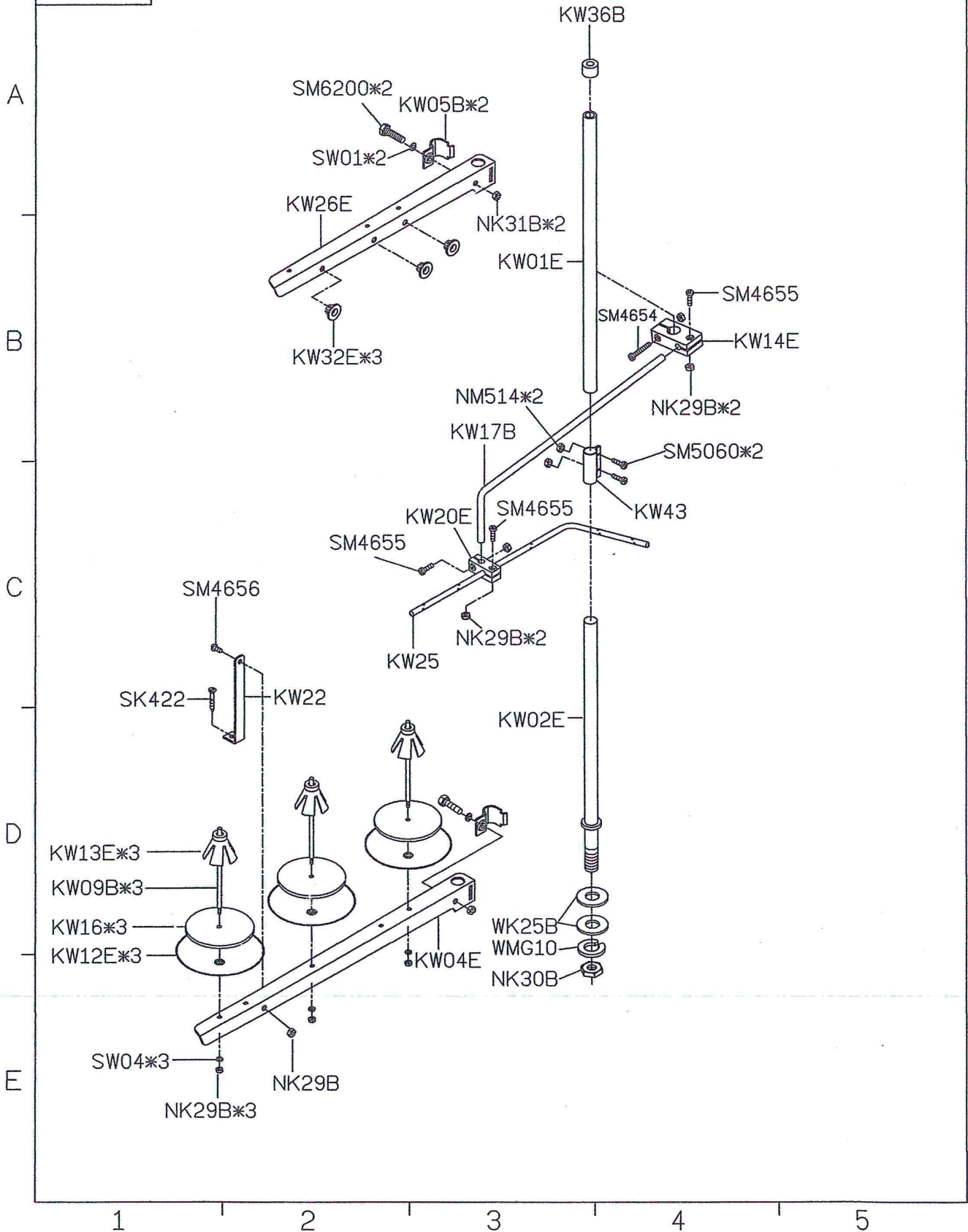

SIRUBA PARTS LIST	Series	Parts Group	Subclass / Remark	Page
	拷克	KW		2/4
	Overlock			Date
	含MO6800系列			2022/07/11

KW40E-4

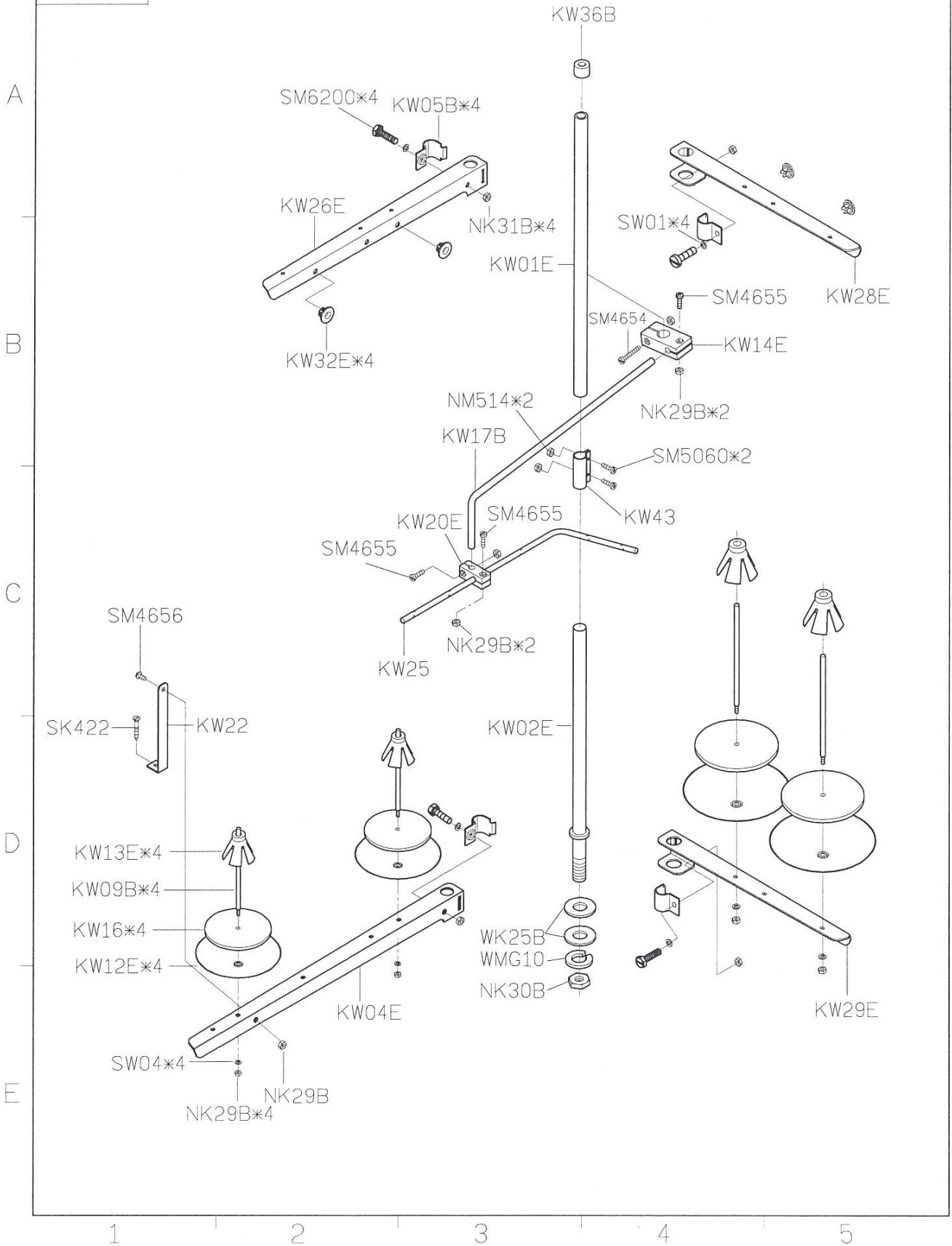

SIRUBA PARTS LIST	Series	Parts Group	Subclass / Remark	Page
	拷克	KW		3/4
	Overlock			Date
	含MO6800系列			2022/07/11

KW40E-5

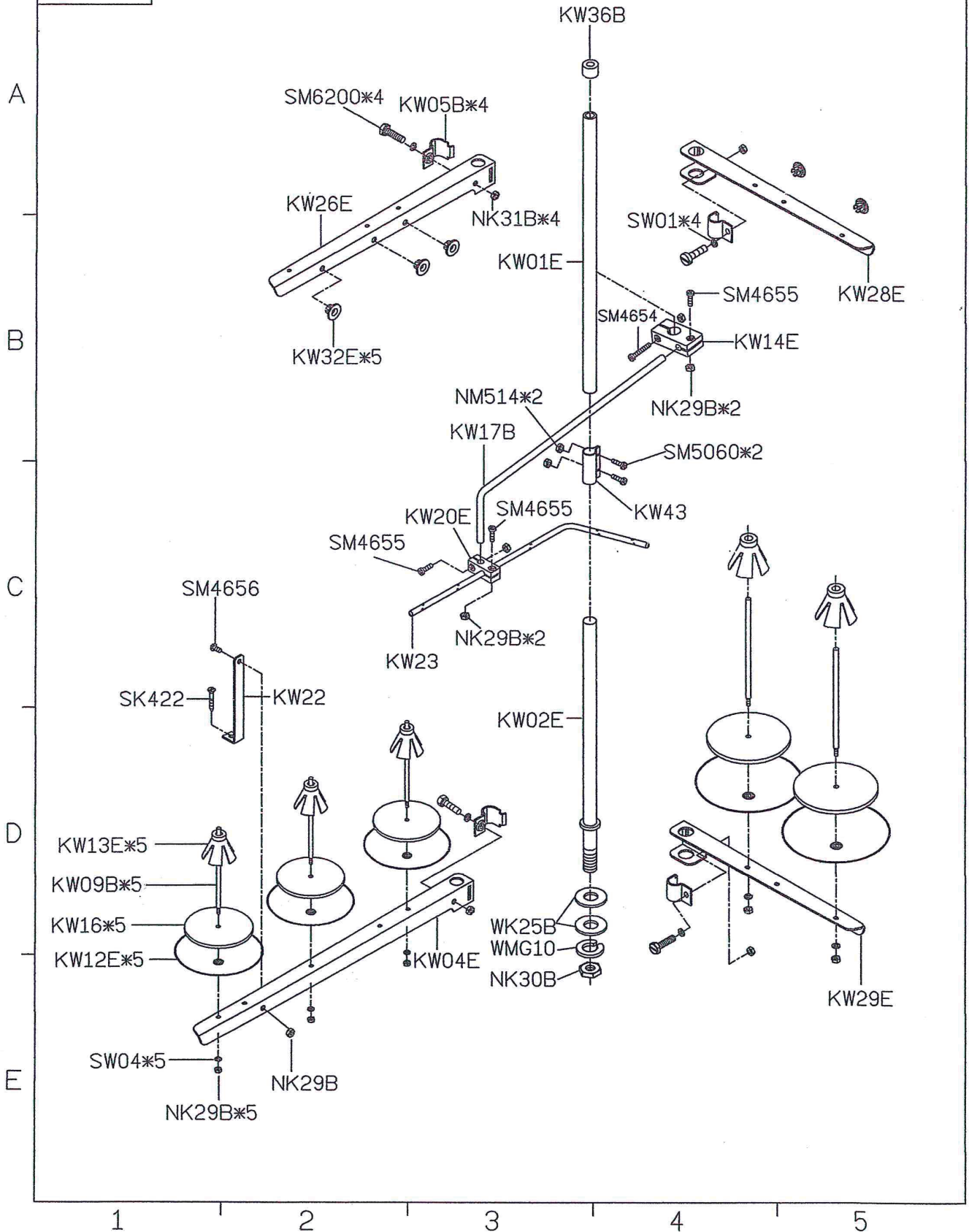

SIRUBA PARTS LIST	Series	Parts Group	Subclass / Remark	Page
	拷克	KW		4/4
	Overlock			Date
	含MO6800系列			2022/07/11

KW40E-6

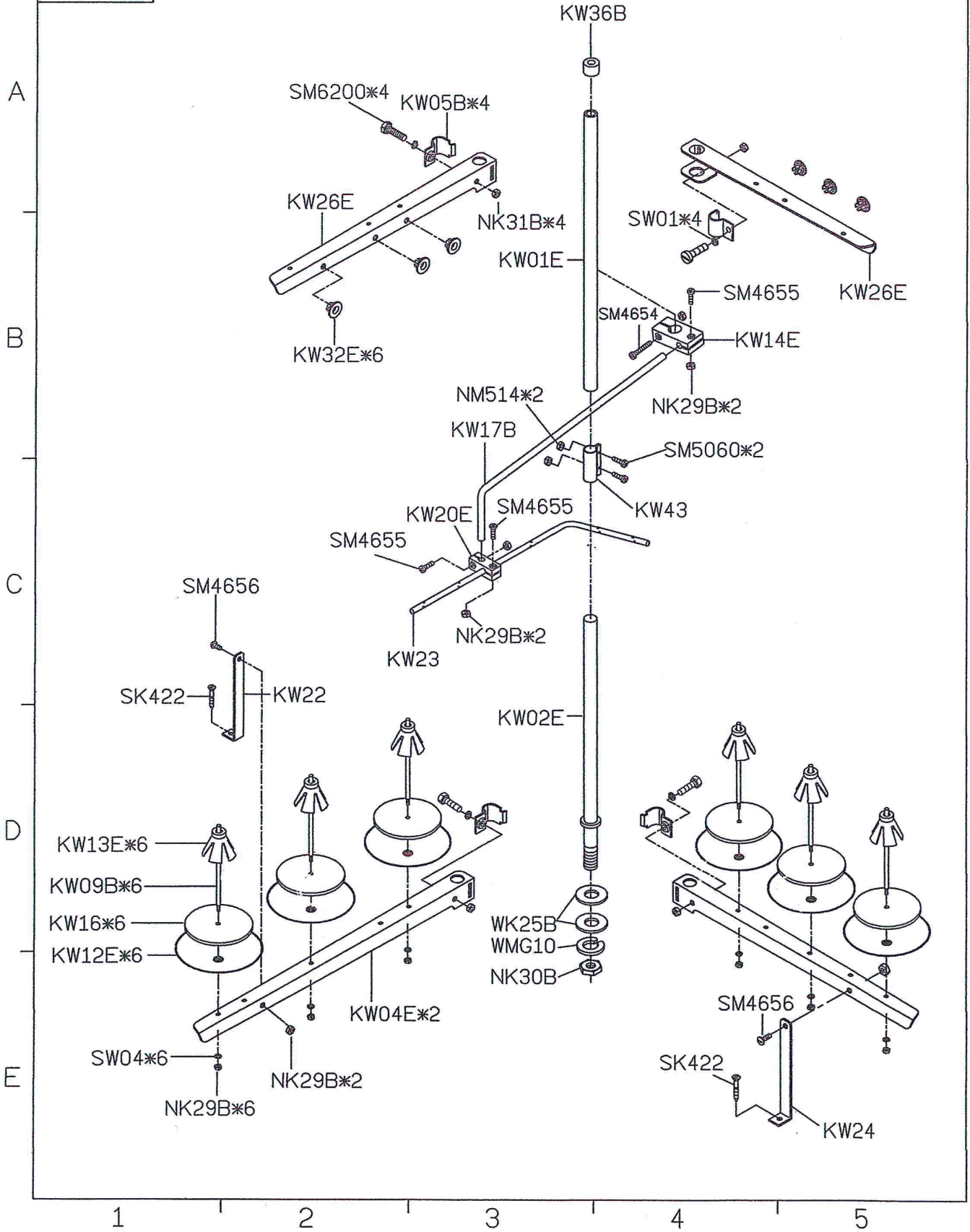

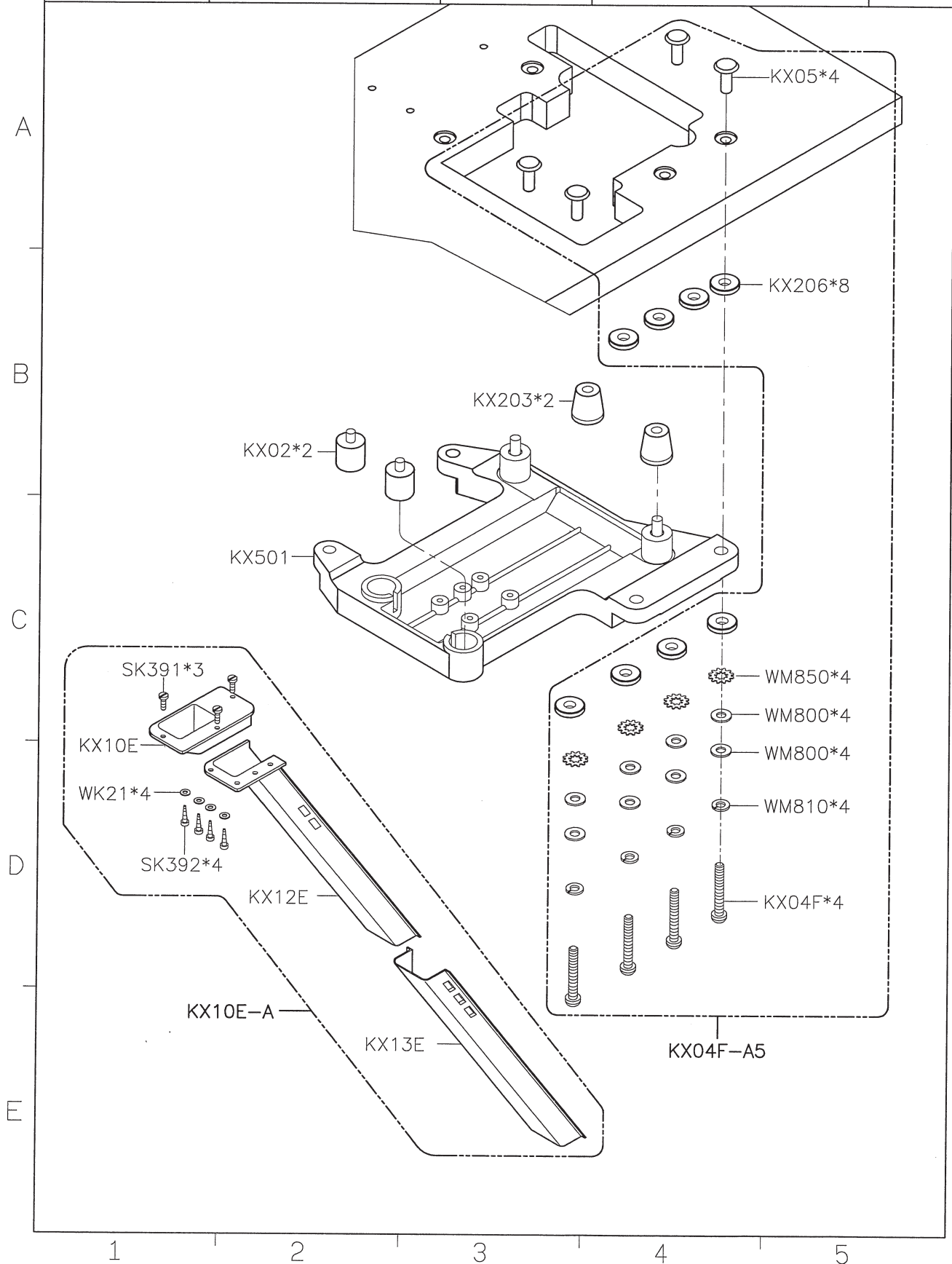

SIRUBA PARTS LIST	Series	Parts Group	Subclass / Remark	Page
	700KST	KY		1/1
				Date
				2020/12/01

KY01-1
防塵罩

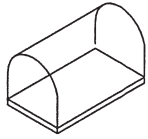

KY02F-A
油罐



KY03
油壺



KY04
漏斗



KY14
內六角螺絲起子

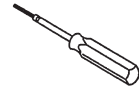

LY33
一字起子

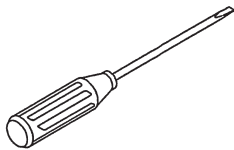

KY18
鑷子



SK216
螺絲



KY201JK
工具袋

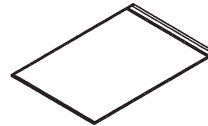

KY30
針板紙

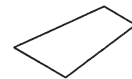

KR55
下刀片

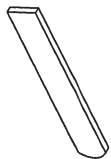

KT14-A
濾油器



KZ03
乾燥劑



針*4
車針



LY35
一字起子



KY21-A/MY21-A
鉤子/鍊條



SIRUBA PARTS LIST	Series	Parts Group	Subclass / Remark	Page
	700KST	KZ		1/1
				Date 2013/10/09

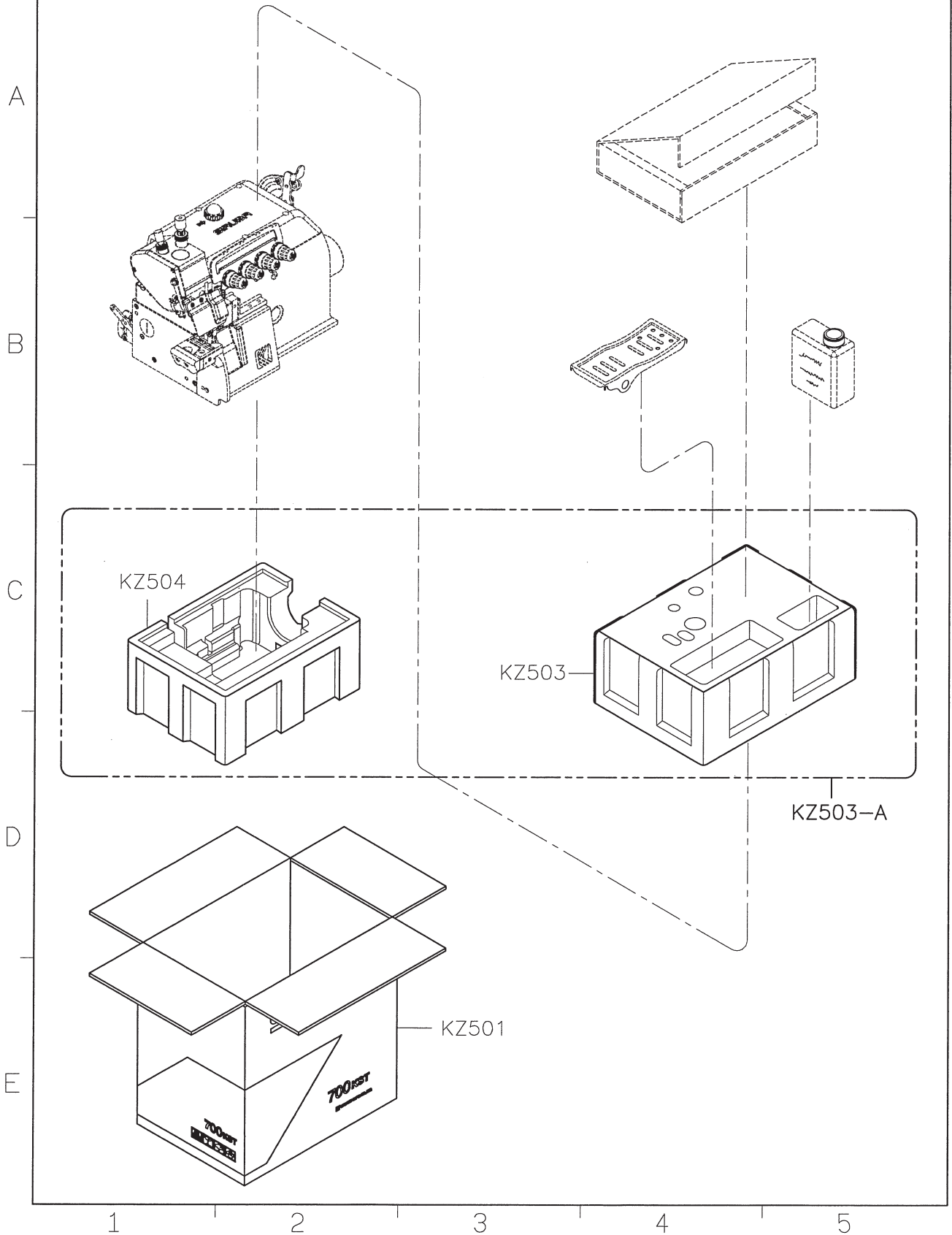

SIRUBA PARTS LIST	Series	Parts Group	Subclass / Remark	Page
	700KST	FT		1/4
				Date
				2015/07/21

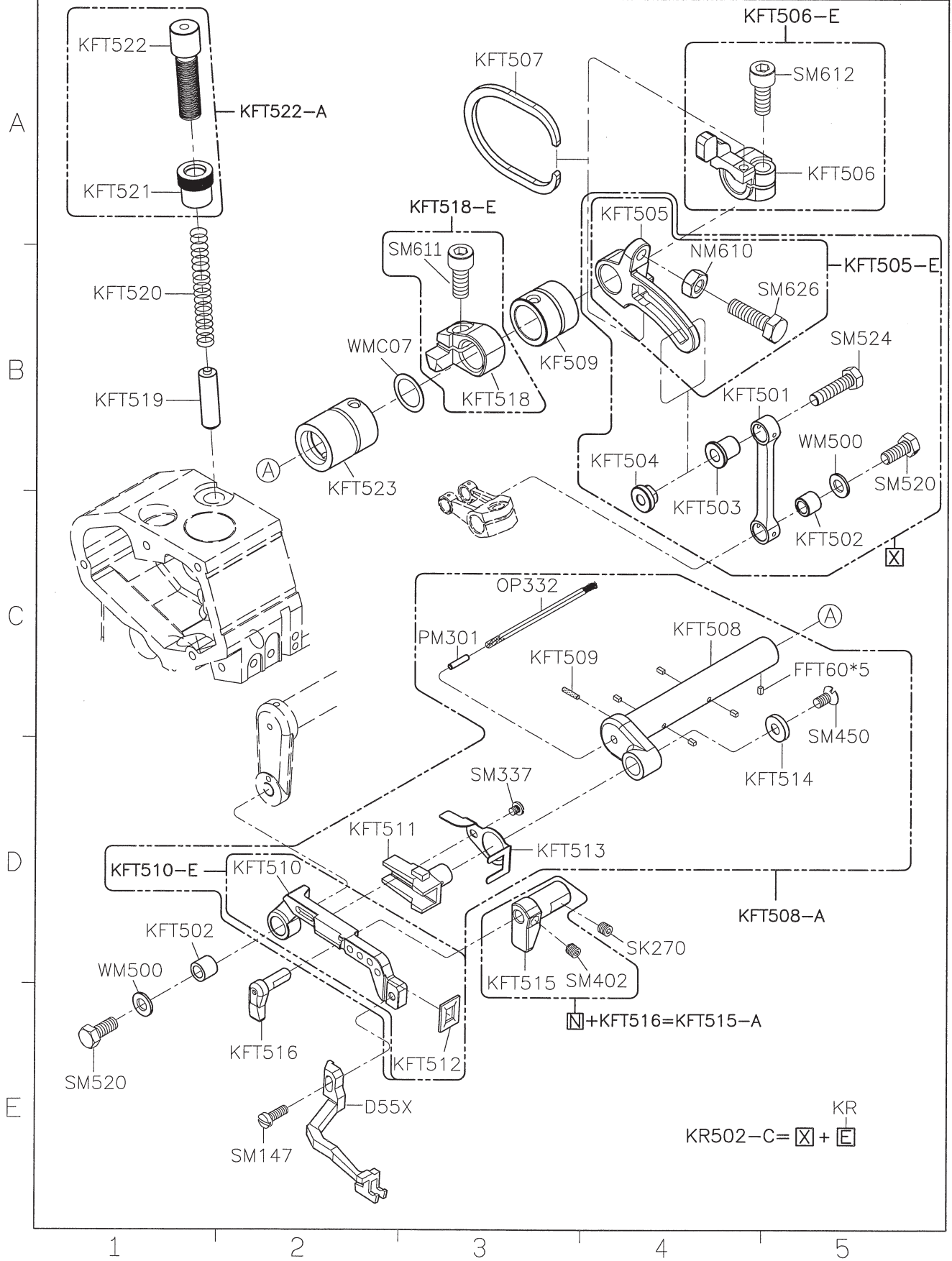

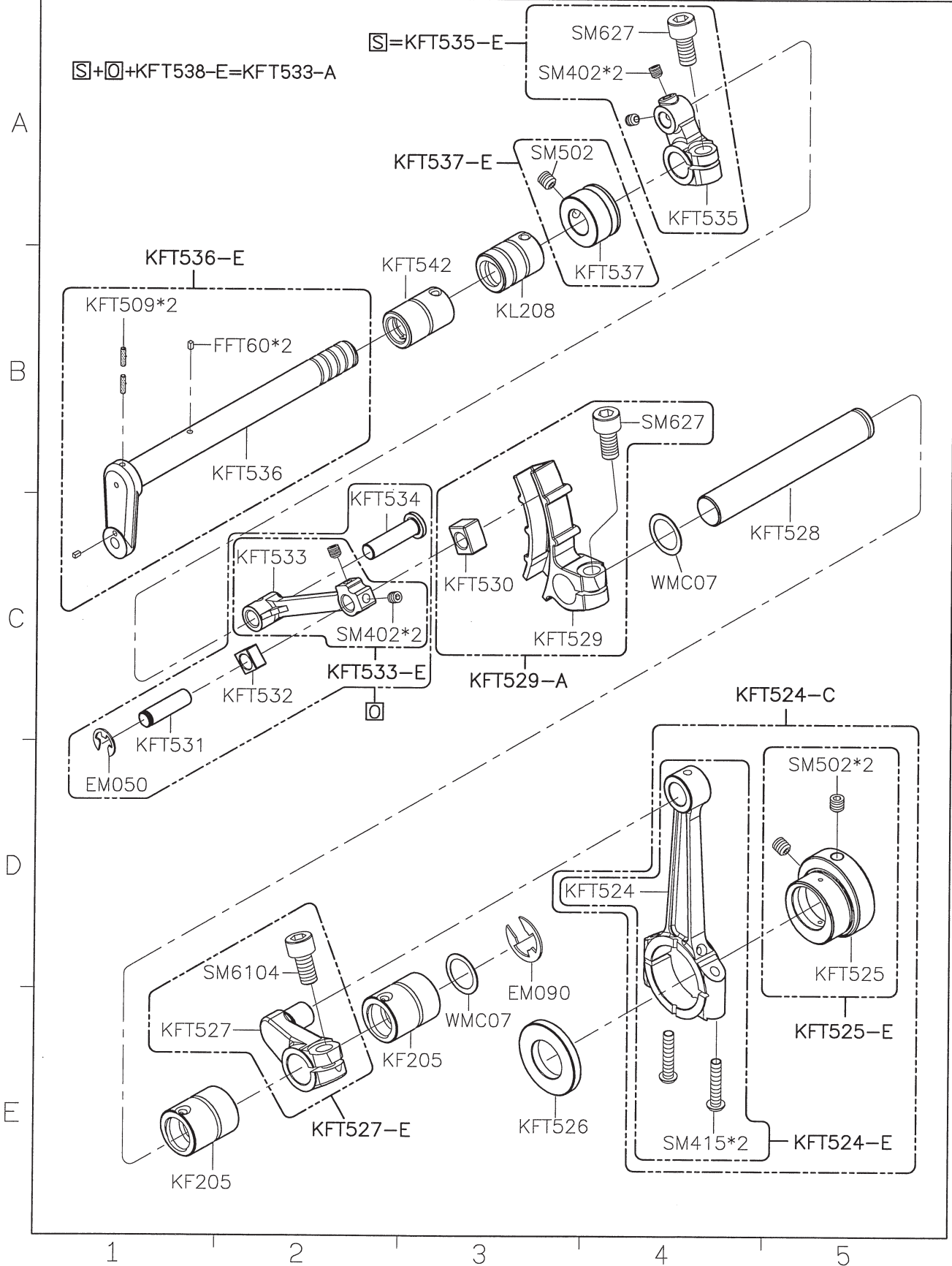

SIRUBA PARTS LIST	Series	Parts Group	Subclass / Remark	Page
	700KST	FT		3/4
				Date
				2015/06/23

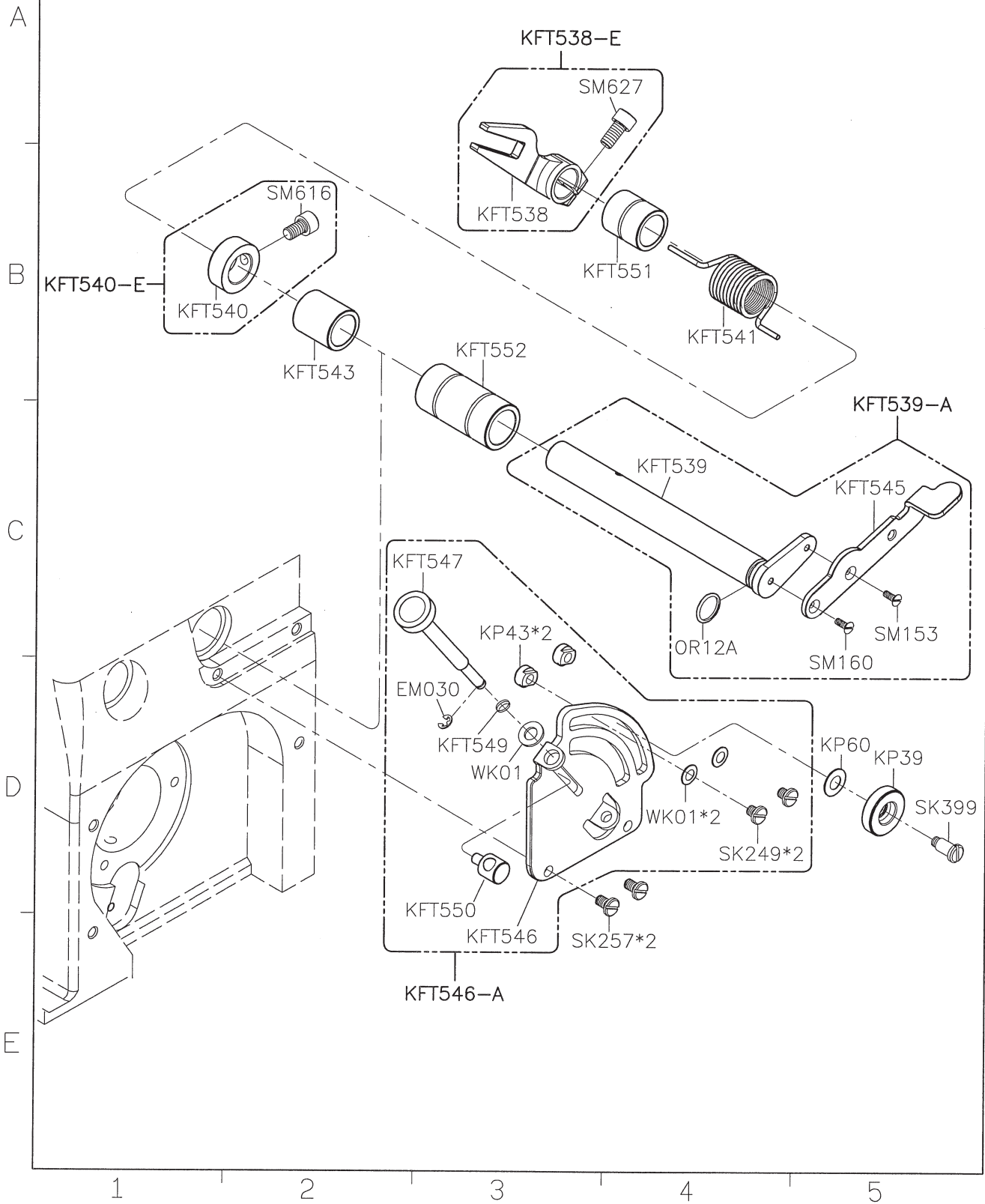

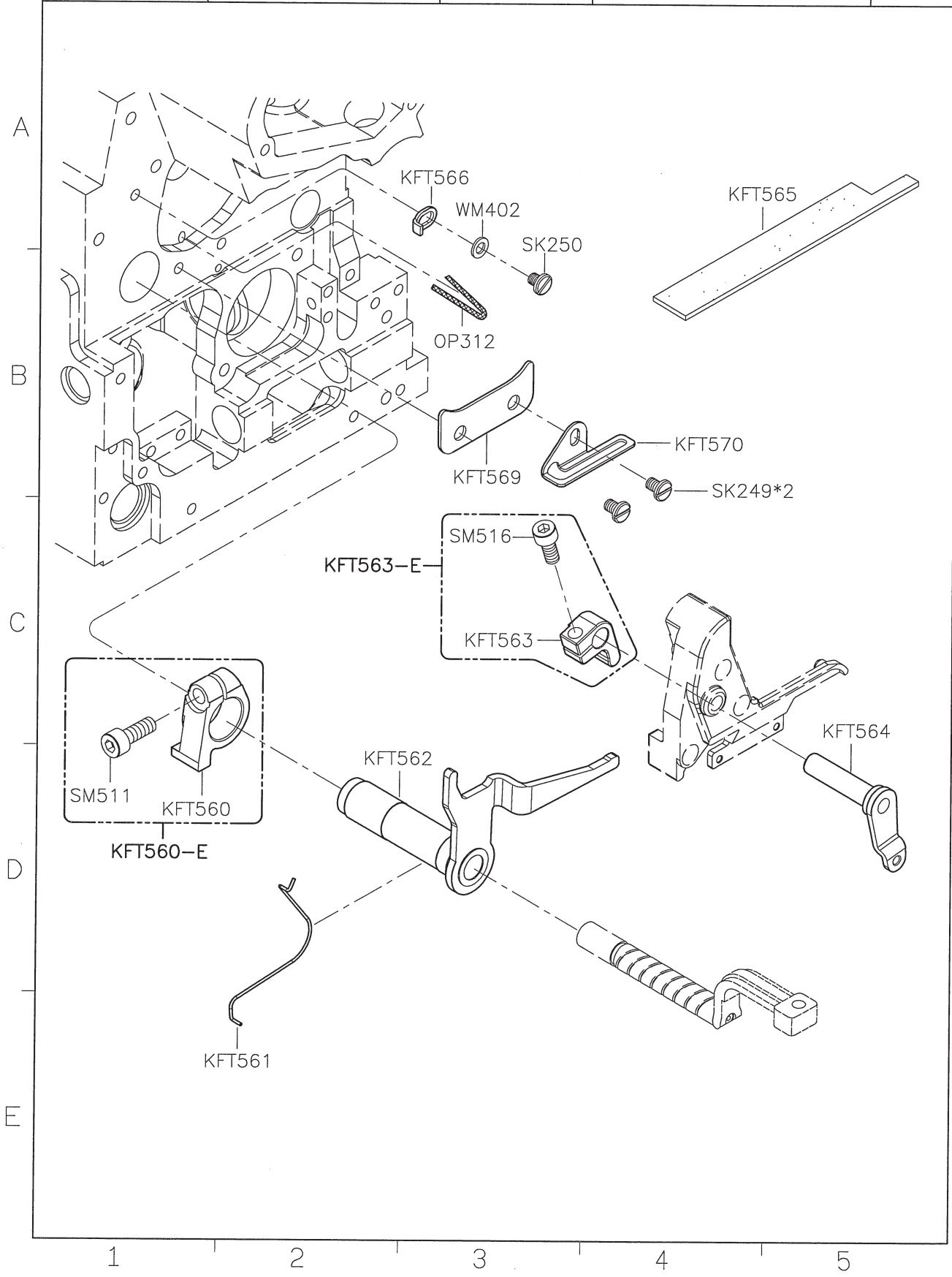

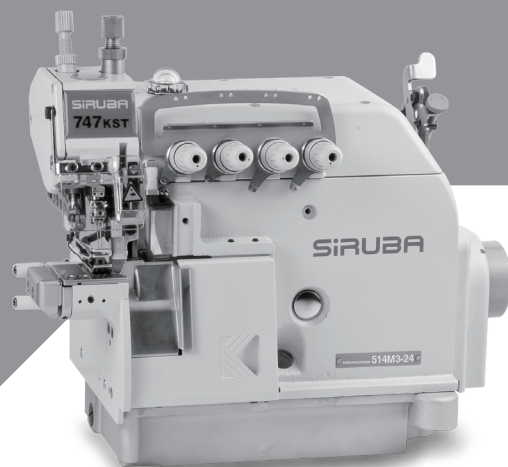

高林股份有限公司
KAULIN MFG. CO., LTD.

由於對產品的改良及更新，本產品使用說明書中與零件圖之產品及外觀的修改恕不事先通知！
The specification and/or appearances of the equipment described in this instruction book & parts list are subject to change because of modification which will without previous notice.
KZ508.MAR.2023